

Cisco Firewall Video Mentor

David Hucaby, CCIE No. 4594

Cisco Press

800 East 96th Street

Indianapolis, Indiana 46240 USA

Cisco Firewall Video Mentor

David Hucaby, CCIE No. 4594

Copyright© 2008 Cisco Systems, Inc.

Published by:

Cisco Press

800 East 96th Street

Indianapolis, IN 46240 USA

All rights reserved. No part of this book may be reproduced or transmitted in any form or by any means, electronic or mechanical, including photocopying, recording, or by any information storage and retrieval system, without written permission from the publisher, except for the inclusion of brief quotations in a review.

Printed in the United States of America

First Printing May 2008

ISBN-13: 978-1-58720-198-1

ISBN-10: 1-58720-198-4

Warning and Disclaimer

This book and video product are designed to provide information about configuring Cisco firewalls. Every effort has been made to make this book as complete and accurate as possible, but no warranty or fitness is implied.

The information is provided on an “as is” basis. The author, Cisco Press, and Cisco Systems, Inc. shall have neither liability nor responsibility to any person or entity with respect to any loss or damages arising from the information contained in this book or from the use of the discs or programs that may accompany it.

The opinions expressed in this book belong to the author and are not necessarily those of Cisco Systems, Inc.

Publisher

Paul Boger

Associate Publisher

Dave Dusthimer

Cisco Representative

Anthony Wolfenden

Cisco Press Program Manager

Jeff Brady

Executive Editor

Brett Bartow

Managing Editor

Patrick Kanouse

Development Editor

Andrew Cupp

Project Editor

Jennifer Gallant

Copy Editor

Gayle Johnson

Technical Editor

Mark Macumber

Team Coordinator

Vanessa Evans

Book Designer

Louisa Adair

Composition

Mark Shirar

Proofreader

Water Crest Publishing, Inc.

Introduction

The Cisco Firewall Video Mentor supplies 16 instructional videos that cover a variety of firewall configuration tasks. Because firewall features can be complex and tedious to configure, each video presents a scenario that visually demonstrates a feature configuration step by step, along with a running audio commentary.

This product is one of several in the Cisco Press Video Mentor series. The Video Mentor series offers a learning environment that is different from that of printed books, where you can only read about concepts and look at static examples. With the video labs, you can learn about concepts much as you would in a classroom setting, with a live instructor. As well, you can watch configurations and examples unfold, step by step, with explanations along the way.

The Video Mentor covers the firewall features found in the Cisco ASA 5500 family of security appliances, as well as the Cisco Catalyst 6500 Firewall Services Module (FWSM).

Who Should Use the Cisco Firewall Video Mentor?

The Cisco Firewall Video Mentor is intended for people who are involved in firewall installation and administration. Although it is not designed around any specific Cisco course or exam, it can be used to augment self-study books about firewalls and security topics.

Because of the multimedia format, the Video Mentor uses video and audio media to deliver information more effectively than printed material alone—especially for visual learners.

Goals and Methods

The Cisco Firewall Video Mentor shows the author's computer desktop as a firewall is being configured and tested. A running audio commentary accompanies the video so that every activity is explained.

Most of the video labs follow the same format, using these steps as they are appropriate to the lab:

- Step 1.** The video begins by listing goals or topics for the lab.
- Step 2.** An overview of specific firewall features is given.
- Step 3.** A scenario involving a firewall feature is presented, and related command syntax is discussed.
- Step 4.** A terminal emulator window shows how the firewall feature is configured with the command-line interface, step by step.
- Step 5.** The configuration is reset, and the same scenario is rebuilt using the Adaptive Security Device Manager (ASDM) management tool.

Cisco Firewall Video Mentor Contents

The Cisco Firewall Video Mentor contains a DVD and a printed booklet. The DVD consists of a series of 16 video labs. The DVD is viewed on a computer screen and is optimized for display in a 1024×768-pixel minimum area.

The booklet contains information that you can use as a reference while watching the video labs. It is not meant to be a standalone tool. The booklet has a section devoted to each of the 16 video labs, containing the figures and configuration information used in the video.

Each booklet section includes the following:

- A list of objectives or topics for the video lab
- A description of the scenario, broken into steps
- The initial configuration entered in the firewall *before* the video lab begins
- The configuration commands that are entered *during* the video lab

The booklet also includes topology figures from the video labs as appropriate.

The booklet is also available in PDF format on the disc. You can switch between displaying the video and the booklet as you work your way through the video labs.

How the Cisco Firewall Video Mentor Is Organized

When the DVD starts, the Cisco Firewall Video Mentor application displays the list of 16 video labs. From the initial menu, you can also view an introductory video that describes the entire product. The video labs are organized as follows:

Lab 1, “Initial Configuration”: This lab demonstrates how a new firewall can be configured for the first time. The command-line interface (CLI) is used while the computer is connected to the firewall console.

Lab 2, “Configuring Interfaces”: This lab shows how the firewall mode (transparent or routed) is set. Then a variety of firewall interfaces, both physical and logical, are configured.

Lab 3, “Setting Up Routing”: In this lab, sources of routing information are configured. Static routes, default routes, standby ISPs, and the OSPF dynamic routing protocol are all demonstrated.

Lab 4, “Firewall Administration over the Network”: This lab shows how a firewall can be configured for remote management through Telnet, SSH, and ASDM sessions.

Lab 5, “Using Multiple Security Contexts”: This lab demonstrates how a single physical firewall platform can be configured to run multiple instances of virtual firewalls or security contexts.

Lab 6, “Using Failover for High Availability”: In this lab, two firewalls are configured as a failover pair. This enables them to operate in a redundant fashion, increasing their availability during a failure.

Lab 7, “Failover in Action”: This lab demonstrates several different kinds of failures, triggering the failover operation presented in Lab 6. A “hitless” upgrade is also shown, in which the operating system of each firewall in a failover pair is upgraded without impacting the traffic passing through.

Lab 8, “Setting Up Address Translation and Connection Limits”: This lab shows examples of six different ways to configure address translation on a firewall.

Lab 9, “Setting Up Firewall Rules”: In this lab, security policies are defined through access list configuration. Furthermore, access lists are configured in a more organized, compact fashion with object groups.

Lab 10, “Setting Up a DMZ”: This lab demonstrates how additional interfaces can be added to a firewall, beyond the simple “inside” and “outside” interfaces.

Lab 11, “Setting Up Logging”: In this lab, a firewall is configured to generate and send logging messages to a collection point. After they are collected, the messages can be analyzed, or they can become a record for an audit trail.

Lab 12, “Using MPF to Control Layer 3/4 Connections”: This lab demonstrates how the Modular Policy Framework (MPF) is used to define a policy that sets connection limits on UDP and TCP connections.

Lab 13, “Using MPF to Perform QoS Queuing and Policing”: In this lab, the MPF is used to configure priority queuing policies that handle specific types of traffic more efficiently than other traffic. In addition, policing is used to limit the bandwidth used by certain types of traffic.

Lab 14, “Using MPF to Tune Application Inspection Engines”: This lab shows how a firewall can be configured to change how it inspects traffic related to specific applications.

Lab 15, “Testing Security Policies with Packet Tracer”: This lab demonstrates the Packet Tracer tool and how it can be used to verify a firewall’s configuration. A virtual packet is sent from one interface to another, with a graphical display showing what happens to the packet at each step along the way.

Lab 16, “Capturing Traffic”: In this lab, a firewall is configured to capture traffic for further analysis. Both the CLI and ASDM are used to configure a capture session and to display the packets captured.

Failover in Action

This Cisco Firewall Video Mentor lab demonstrates several different conditions that cause a failure in a firewall interface or unit. This, in turn, triggers the failover operation.

This lab also works through the “hitless” upgrade process, where you can upgrade the operating system image in each of the active-active failover units—without impacting the traffic passing through the firewall pair.

The objectives of this lab are as follows:

- Observe a physical interface failure
- Observe a logical interface failure
- Observe a failover unit failure
- Observe a hitless upgrade

Scenario

This lab contains several failover demonstrations, using the two firewalls from Lab 6 configured as a failover pair. A network diagram of the failover pair is shown in Figure 7-1.

Figure 7-1 Network Diagram for Lab 7 Scenarios

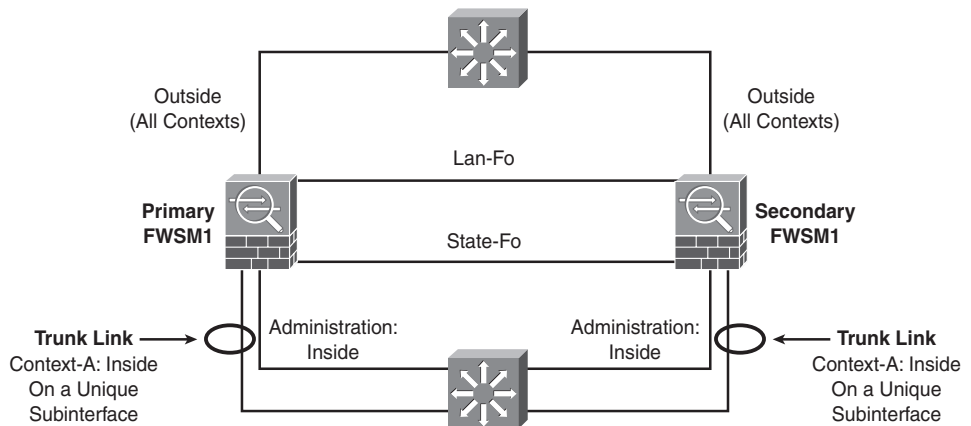

- Scenario 1: Force the link state on the “admin” context inside interface to go down. This causes a failure on a physical firewall interface, which triggers a failover operation.
- Scenario 2: Remove the VLAN used on the “context-a” context inside interface while the interface stays up. This causes a failure on a logical interface, which indirectly triggers a failover operation.

- Scenario 3: Reload the primary firewall unit suddenly, as if it experiences a power cycle. This causes the failure of an entire firewall unit, which triggers a failover operation.
- Scenario 4: Manually control the failover operation so that the code image can be upgraded on each firewall unit. The upgrades occur while live connections are being handled by the failover pair, such that no traffic is impacted or lost.

Initial Configurations

The failover pair of ASA devices configured in Lab 6 is used for the interface and unit failover demonstrations. No additional configuration commands are necessary to perform the first three scenarios.

The final scenario involves active-active failover and a hitless upgrade on two running firewalls. The FWSM platform is used. The initial configurations are listed in the Scenario 4 section.

Video Presentation Reference

Refer to the following descriptions of each scenario presented in Lab 7.

Scenario 1: Physical Interface Failure

In this scenario, the interface polltime remains configured at 500 ms, with a holdtime of 5 seconds. The switch interface connected to the primary unit's "admin" context inside interface (physical interface Ethernet0/0) is shut down, causing the link status to go down.

No additional configuration is necessary on the failover pair.

Scenario 2: Logical Interface Failure

In this scenario, the interface polltime remains configured at 500 ms, with a holdtime of 5 seconds. The inside interface of the "context-a" context is mapped to VLAN 100, which is carried over a trunk link from an upstream switch to each firewall in the failover pair.

On the switch connected to the primary failover unit, VLAN 100 is removed from the trunk. This simulates a failure on a logical interface, where the two failover units can no longer communicate with each other on the context interface.

No additional configuration is necessary on the failover pair.

Scenario 3: Failover Unit Failure

In this scenario, the unit polltime remains configured at 200 ms, with a holdtime of 800 ms. You reload the entire primary failover unit by entering the **reload** command from the system execution space.

This simulates a failover unit failure, where the secondary unit can no longer detect the primary unit.

No additional configuration is necessary on the failover pair.

Scenario 4: Hitless Code Upgrade

In this scenario, the two failover units are configured for active-active failover operation. This scenario is unique because it uses two FWSMs as a failover pair.

The primary FWSM unit begins with the multiple context configuration that resulted from Lab 6. The initial Catalyst 6500 configuration commands related to FWSM operation are shown in Example 7-1. In this case, the primary FWSM is contained in module 3, and the secondary FWSM in slot 4.

Example 7-1 Initial Catalyst 6500 Supervisor Configuration

```

vlan 2
  name lan-fo
!
vlan 3
  name stateful-fo
!
vlan 10
  name FWSM-outside
!
vlan 100
  name FWSM-inside
!
vlan 101
  name context-a-inside
!
vlan 102
  name context-b-inside
  firewall vlan-group 1 2,3,10,100-103
!
firewall module 3 vlan-group 1
firewall module 4 vlan-group 1

```

The initial configuration commands for the primary FWSM system execution space are shown in Example 7-2.

Example 7-2 Initial FWSM System Execution Space Configuration

```
hostname fws1
domain-name mycompany.com
enable password iE9e1CM0vCJAfUw3 encrypted
passwd 11L6nJyCpFrdy9oK encrypted
!
interface Vlan2
  description LAN Failover Interface
!
interface Vlan3
  description STATE Failover Interface
!
interface Vlan10
!
interface Vlan100
!
interface Vlan101
!
interface Vlan102
!
failover
failover lan unit primary
failover lan interface lan-fo Vlan2
failover polltime unit msec 500 holdtime 3
failover key *****
failover replication http
failover link state-fo Vlan3
failover interface ip lan-fo 192.168.254.1 255.255.255.0 standby 192.168.254.2
failover interface ip state-fo 192.168.253.1 255.255.255.0 standby 192.168.253.2
failover group 1
  preempt
  polltime interface 3
failover group 2
  secondary
  preempt
  polltime interface 3
!
admin-context admin
context admin
  description Admin context
  allocate-interface Vlan10
  allocate-interface Vlan100
  config-url disk:/admin.cfg
  join-failover-group 1
!
```

Example 7-2 Initial FWSM System Execution Space Configuration

```

context context-a
  description Example context A
  allocate-interface Vlan10 intf0
  allocate-interface Vlan101 intf1
  config-url disk:/context-a.cfg
  join-failover-group 1
!

context context-b
  description Example context B
  allocate-interface Vlan102 intf1
  allocate-interface Vlan103 intf0
  config-url disk:/context-b.cfg
  join-failover-group 2

```

The initial configuration commands for the primary FWSM “admin” context are shown in Example 7-3.

Example 7-3 Initial FWSM “admin” Context Configuration

```

hostname admin
passwd l1L6nJyCpFrDy9oK encrypted
enable password iE9e1CM0vCJAfUw3 encrypted
!
interface Vlan10
  nameif outside
  security-level 0
  ip address 192.168.100.1 255.255.255.0 standby 192.168.100.2
!
interface Vlan100
  nameif inside
  security-level 100
  ip address 192.168.1.1 255.255.255.0 standby 192.168.1.2
!
monitor-interface outside
route outside 0.0.0.0 0.0.0.0 192.168.100.3 1
http 0.0.0.0 0.0.0.0 outside
http server enable
ssh 0.0.0.0 0.0.0.0 outside
ssh version 2
!
tftp-server outside 192.168.100.239 /

```

The initial configuration commands for the primary FWSM “context-a” context are shown in Example 7-4.

Example 7-4 Initial FWSM “context-a” Context Configuration

```
hostname context-a
domain-name mycompany.com
passwd 1lL6nJyCpFrDy9oK encrypted
enable password iE9e1CM0vCJAfUw3 encrypted
!
interface intf0
  nameif outside
  security-level 0
  ip address 192.168.100.10 255.255.255.0 standby 192.168.100.11
!
interface intf1
  nameif inside
  security-level 100
  ip address 192.168.2.1 255.255.255.0 standby 192.168.2.2
!
access-list acl_outside extended permit ip 172.21.4.0 255.255.254.0 host
  192.168.100.100
access-list acl_inside extended permit ip 192.168.2.0 255.255.255.0 any
access-list acl_in extended permit ip 192.168.2.0 255.255.255.0 any
!
static (inside,outside) 192.168.100.100 192.168.2.100 netmask 255.255.255.255
!
access-group acl_outside in interface outside
access-group acl_in in interface inside
route outside 0.0.0.0 0.0.0.0 192.168.100.3 1
!
http server enable
http 0.0.0.0 0.0.0.0 outside
ssh 0.0.0.0 0.0.0.0 outside
ssh timeout 30
ssh version 2
```

The initial configuration commands for the primary FWSM “context-b” context are shown in Example 7-5.

Example 7-5 Initial FWSM “context-b” Context Configuration

```

hostname context-b
domain-name mycompany.com
passwd 1lL6nJyCpFrDy9oK encrypted
enable password iE9e1CM0vCJAfUw3 encrypted
!
interface intf1
  nameif inside
  security-level 100
  ip address 192.168.3.1 255.255.255.0 standby 192.168.3.2
!
interface intf0
  nameif outside
  security-level 0
  ip address 192.168.100.20 255.255.255.0 standby 192.168.100.21
!
http 0.0.0.0 0.0.0.0 outside
http server enable
ssh 0.0.0.0 0.0.0.0 outside
ssh timeout 30
ssh version 2

```

Finally, the initial configuration for the system execution space and all contexts are identical on the secondary FWSM unit—except for the failover configuration in the system execution space. The secondary unit’s failover configuration commands are shown in Example 7-6.

Example 7-6 Initial Secondary FWSM Failover Configuration

```

failover
failover lan unit secondary
failover lan interface lan-fo Vlan2
failover polltime unit msec 500 holdtime 3
failover key *****
failover replication http
failover link state-fo Vlan3
failover interface ip lan-fo 192.168.254.1 255.255.255.0 standby 192.168.254.2
failover interface ip state-fo 192.168.253.1 255.255.255.0 standby 192.168.253.2
failover group 1
  preempt
  polltime interface 3
failover group 2
  secondary
  preempt
  polltime interface 3

```

The primary unit is active for the “admin” and “context-a” contexts, and the secondary unit is active for the “context-b” context. The code image running on each failover unit is upgraded from 3.2(1) to 3.2(2) individually, as part of a hitless upgrade process.

The following steps demonstrate the hitless upgrade. All commands are entered in the system execution space on the primary unit.

Step 1. Download the new code image to each failover unit.

The code image is downloaded into FWSM flash with the following command:

```
Firewall# copy ftp: flash:image
```

Currently the FWSM platform supports only one code image in flash memory. Therefore, you don’t have to configure the specific image location and filename, as the ASA platform requires.

Step 2. Force the primary unit to be active in all contexts.

The following command causes the primary unit to immediately take the active role in all contexts:

```
Firewall# failover active
```

Step 3. Reload the secondary unit:

```
Firewall# failover reload-standby
```

When you force the secondary unit to reload, it automatically picks up the new code image.

Step 4. Swap failover roles.

As soon as the secondary unit finishes reloading and the failover operation has stabilized, the following command is used to push the active role to the secondary unit:

```
Firewall# no failover active
```

The primary unit immediately tells the secondary unit to take over the active role in all contexts, while the primary unit assumes the standby role.

Step 5. Reload the primary unit:

```
Firewall# reload
```

When you force the primary unit to reload, it automatically picks up the new code image. In the meantime, the secondary unit handles all firewall operations.

Step 6. Resume the original failover roles.

As soon as the primary unit has finished reloading and the failover operation has stabilized, the unit needs to take over the active role in the “admin” and “context-a” contexts—returning to the role it had before the hitless upgrade began. The following command can be used to accomplish this:

```
Firewall# failover active group 1
```

However, because the primary unit has been configured to preempt the active role for failover group 1, it automatically assumes the active role as soon as it reloads.