



# Official Cert Guide

Learn, prepare, and practice for exam success



# Cisco CCNA

## Routing and Switching

## ICND2 200-101

### Academic Edition

[ciscopress.com](http://ciscopress.com)

WENDELL ODOM, CCIE® No. 1624

FREE SAMPLE CHAPTER



SHARE WITH OTHERS

In addition to the wealth of updated content, this new edition includes a series of free hands-on exercises to help you master several real-world configuration and troubleshooting activities. These exercises can be performed on the CCNA ICND2 200-101 Network Simulator Lite software included for free on the DVD that accompanies this book. This software, which simulates the experience of working on actual Cisco routers and switches, contains the following 13 free lab exercises:

1. EIGRP Serial Configuration I Skill Builder Lab
2. EIGRP Serial Configuration II Skill Builder Lab
3. EIGRP Serial Configuration III Skill Builder Lab
4. EIGRP Frame Relay Configuration I Skill Builder Lab
5. EIGRP Frame Relay Configuration II Skill Builder Lab
6. EIGRP Route Tuning I Skill Builder Lab
7. EIGRP Route Tuning II Skill Builder Lab
8. EIGRP Neighbors II Skill Builder Lab
9. EIGRP Neighbors III Skill Builder Lab
10. EIGRP Configuration I Configuration Scenario
11. EIGRP Configuration II Configuration Scenario
12. EIGRP Metric Manipulation Configuration Scenario
13. Path Troubleshooting IV Troubleshooting Scenario

If you are interested in exploring more hands-on labs and practicing configuration and troubleshooting with more router and switch commands, check out our full simulator product offerings at <http://www.pearsonitcertification.com/networksimulator>.

CCNA ICND2 200-101 Network Simulator Lite minimum system requirements:

- Microsoft Windows XP (SP3), Windows Vista (32-bit/64-bit) with SP1, Windows 7 (32-bit/64-bit) or Windows 8 (32-bit/64-bit, x86 processors), Mac OS X 10.6, 10.7, or 10.8
- Intel Pentium III 1GHz or faster processor
- 512 MB RAM (1GB recommended)
- 1 GB hard disk space
- 32-bit color depth at 1024x768 resolution
- Adobe Acrobat Reader version 8 and above

Other applications installed during installation:

- Adobe AIR 3.6.0
- Captive JRE 6

*Cisco CCNA Routing and Switching ICND2 200-101 Official Cert Guide, Academic Edition* is part of a recommended learning path from Cisco that includes simulation and hands-on training from authorized Cisco Learning Partners and self-study products from Cisco Press. To find out more about instructor-led training, e-learning, and hands-on instruction offered by authorized Cisco Learning Partners worldwide, please visit [www.cisco.com/go/authorizedtraining](http://www.cisco.com/go/authorizedtraining).

# **Cisco** **CCNA**

Routing and Switching  
ICND2 200-101

**Official** Cert Guide

Academic Edition

**WENDELL ODOM**, CCIE No. 1624

**Cisco Press**

800 East 96th Street  
Indianapolis, IN 46240

# **Cisco CCNA Routing and Switching ICND2 200-101** Official Cert Guide, Academic Edition

Wendell Odom, CCIE No. 1624

Copyright© 2013 Pearson Education, Inc.

Published by:

Cisco Press

800 East 96th Street

Indianapolis, IN 46240 USA

All rights reserved. No part of this book may be reproduced or transmitted in any form or by any means, electronic or mechanical, including photocopying, recording, or by any information storage and retrieval system, without written permission from the publisher, except for the inclusion of brief quotations in a review.

Printed in the United States of America

Second Printing: October 2013

Library of Congress Control Number: 2013939885

ISBN-13: 978-1-58714-488-2

ISBN-10: 1-58714-488-3

## **Warning and Disclaimer**

This book provides information about the Cisco 200-101 ICND2 and 200-120 CCNA exams. Every effort has been made to make this book as complete and as accurate as possible, but no warranty or fitness is implied.

The information is provided on an “as is” basis. The authors, Cisco Press, and Cisco Systems, Inc. shall have neither liability nor responsibility to any person or entity with respect to any loss or damages arising from the information contained in this book or from the use of the discs or programs that may accompany it.

The opinions expressed in this book belong to the author and are not necessarily those of Cisco Systems, Inc.

## **Trademark Acknowledgments**

All terms mentioned in this book that are known to be trademarks or service marks have been appropriately capitalized. Cisco Press or Cisco Systems, Inc., cannot attest to the accuracy of this information. Use of a term in this book should not be regarded as affecting the validity of any trademark or service mark.

## Corporate and Government Sales

The publisher offers excellent discounts on this book when ordered in quantity for bulk purchases or special sales, which may include electronic versions and/or custom covers and content particular to your business, training goals, marketing focus, and branding interests.

For more information, please contact:  
U.S. Corporate and Government Sales  
1-800-382-3419  
corpsales@pearsontechgroup.com

For sales outside the United States, please contact:  
International Sales  
international@pearsoned.com

## Feedback Information

At Cisco Press, our goal is to create in-depth technical books of the highest quality and value. Each book is crafted with care and precision, undergoing rigorous development that involves the unique expertise of members from the professional technical community.

Readers' feedback is a natural continuation of this process. If you have any comments regarding how we could improve the quality of this book, or otherwise alter it to better suit your needs, you can contact us through email at [feedback@ciscopress.com](mailto:feedback@ciscopress.com). Please make sure to include the book title and ISBN in your message.

We greatly appreciate your assistance.

**Publisher:** Paul Boger

**Associate Publisher:** Dave Dusthimer

**Business Operation Manager, Cisco Press:**  
Jan Cornelssen

**Executive Editor:** Brett Bartow

**Managing Editor:** Sandra Schroeder

**Development Editor:** Andrew Cupp

**Senior Project Editor:** Tonya Simpson

**Copy Editor:** Keith Cline

**Technical Editor:** Elan Beer

**Editorial Assistant:** Vanessa Evans

**Cover Designer:** Mark Shirar

**Illustrator:** Michael Tanamachi

**Composition:** Bronkella Publishing

**Indexer:** Erika Millen

**Proofreader:** Sarah Kearns



**Americas Headquarters**  
Cisco Systems, Inc.  
San Jose, CA

**Asia Pacific Headquarters**  
Cisco Systems (USA) Pte. Ltd.  
Singapore

**Europe Headquarters**  
Cisco Systems International BV  
Amsterdam, The Netherlands

Cisco has more than 200 offices worldwide. Addresses, phone numbers, and fax numbers are listed on the Cisco Website at [www.cisco.com/go/offices](http://www.cisco.com/go/offices).

CCDE, CCENT, Cisco Eos, Cisco HealthPresence, the Cisco logo, Cisco Lumin, Cisco Nexus, Cisco StadiumVision, Cisco TelePresence, Cisco WebEx, DCE, and Welcome to the Human Network are trademarks; Changing the Way We Work, Live, Play, and Learn and Cisco Store are service marks; and Access Registrar, Aironet, AsyncOS, Bringing the Meeting To You, Catalyst, CCDA, CCDP, CCIE, CCIP, CCNA, CCNP, CCSP, CCVP, Cisco, the Cisco Certified Internetwork Expert logo, Cisco IOS, Cisco Press, Cisco Systems, Cisco Systems Capital, the Cisco Systems logo, Cisco Unity, Collaboration Without Limitation, EtherFast, EtherSwitch, Event Center, Fast Step, Follow Me Browsing, FormShare, GigaDrive, HomeLink, Internet Quotient, IOS, iPhone, iQuick Study, IronPort, the IronPort logo, LightStream, Linksys, MediaTone, MeetingPlace, MeetingPlace Chime Sound, MGX, Networkers, Networking Academy, Network Registrar, PCNow, PIX, PowerPanels, ProConnect, ScriptShare, SenderBase, SMARtNet, Spectrum Expert, StackWise, The Fastest Way to Increase Your Internet Quotient, TransPath, WebEx, and the WebEx logo are registered trademarks of Cisco Systems, Inc. and/or its affiliates in the United States and certain other countries.

All other trademarks mentioned in this document or website are the property of their respective owners. The use of the word partner does not imply a partnership relationship between Cisco and any other company. (0812R)

## About the Author

**Wendell Odom**, CCIE No. 1624, has been in the networking industry since 1981. He has worked as a network engineer, consultant, systems engineer, instructor, and course developer; he currently works writing and creating certification tools. He is the author of all the previous books in the Cisco Press *CCNA Official Certification Guide* series, as well as author of the *CCNP ROUTE 642-902 Official Certification Guide*, the *QoS 642-642 Exam Certification Guide*, and co-author of the *CCIE Routing and Switch Official Certification Guide* and several other titles. He is also a consultant for the *CCNA 640-802 Network Simulator* from Pearson and for a forthcoming replacement version of that product. He maintains study tools, links to his blogs, and other resources at <http://www.certskills.com>.

## About the Contributing Author

**Anthony Sequeira**, CCIE No. 15626, is a Cisco Certified Systems Instructor (CCSI) and author regarding all levels and tracks of Cisco certification. Anthony formally began his career in the information technology industry in 1994 with IBM in Tampa, Florida. He quickly formed his own computer consultancy, Computer Solutions, and then discovered his true passion: teaching and writing about Microsoft and Cisco technologies. Anthony joined Mastering Computers in 1996 and lectured to massive audiences around the world about the latest in computer technologies. Mastering Computers became the revolutionary online training company KnowledgeNet, and Anthony trained there for many years. Anthony is currently pursuing his second CCIE in the area of Security and is a full-time instructor for the next generation of KnowledgeNet, StormWind Live. Anthony is also a VMware Certified Professional.

## About the Technical Reviewer

**Elan Beer**, CCIE No. 1837, is a senior consultant and Cisco instructor specializing in data center architecture and multiprotocol network design. For the past 25 years, Elan has designed networks and trained thousands of industry experts in data center architecture, routing, and switching. Elan has been instrumental in large-scale professional service efforts designing and troubleshooting internetworks, performing data center and network audits, and assisting clients with their short- and long-term design objectives. Elan has a global perspective of network architectures via his international clientele. Elan has used his expertise to design and troubleshoot data centers and internetworks in Malaysia, North America, Europe, Australia, Africa, China, and the Middle East. Most recently, Elan has been focused on data center design, configuration, and troubleshooting as well as service provider technologies. In 1993, Elan was among the first to obtain Cisco's Certified System Instructor (CCSI) certification, and in 1996, he was among the first to attain Cisco System's highest technical certification, the Cisco Certified Internetworking Expert. Since then, Elan has been involved in numerous large-scale data center and telecommunications networking projects worldwide.

## **Dedication**

In memory of Carcel Lanier (C.L.) Odom: Dad's Pop, Poppa, wearing khakis, quiet, tearing down the old house (one board at a time), tagging along at the cow sales barn, walking the property, and napping during the Sunday morning sermon.



## Acknowledgments

Although published as a first edition for various reasons, this book (and the companion *Cisco CCENT/CCNA ICND1 100-101 Exam Cert Guide*, Academic Edition) represents the seventh book in a long line of Cisco Press books focused on helping people pass the CCENT and CCNA R/S certifications. Given the long history, many people have worked on these books from their inception back in 1998. To those many people who have touched these books over these past 15 years—technical edits, development, copy edits, project editing, proofing, indexing, managing the production process, interior design, cover design, marketing, and all the other details that happen to get these books out the door—thanks so much for playing a role in this CCENT/CCNA franchise.

Many of the contributors to the previous editions returned to work on creating these new editions, including Development Editor Drew Cupp. Drew kept all the details straight, with my frequent changes to the outlines and titles, keeping the sequencing on track, while still doing his primary job: keeping the text and features clear and consistent throughout the book. Thanks, Drew, for walking me through the development.

Contributing author Anthony Sequeira did a nice job stepping in on the network management part of the book. Anthony was a perfect fit, given his interest in management protocols and tools, and his writing experience and his great teaching skills (with enthusiasm!). Thanks for helping make this book complete and doing such a great job.

As for technical editors, Elan Beer did his normal job. That is, he did his usual amazing job of doing every part of the technical edit job well, from finding the tiny little cross-reference errors that lie pages apart, to anticipating how readers might misunderstand certain phrasing, to being all over the details of every technical feature. Fantastic job as usual; thanks, Elan.

Brett Bartow again served as executive editor of the book, as he has almost since the beginning of these titles. When my family has asked me over the years about Brett's role with these books, the best single word definition is *teammate*. Brett may be employed at Pearson Education, but he is always working with me and for me, watching out for the business end of the books and finding ways to make the publisher/author relationship work seamlessly. Thanks for another great ride through these books, Brett!

Word docs go in, and out come these beautiful finished products. Thanks to Sandra Schroeder, Tonya Simpson, and all the production team for working through the magic that takes those Word docs and makes the beautiful finished product. From fixing all my grammar, crummy word choices, passive-voice sentences, and then pulling the design and layout together, they do it all. Thanks for putting it all together and making it look easy. And Tonya, managing the details through several process steps for roughly 100 elements between the pair of CCNA books in a short timeframe: Wow, thanks for the amazing juggling act! And thanks especially for the attention to detail.

The figures for these books go through a little different process than they do for other books. Together we invested a large amount of labor in updating the figures for these books, both for the design, the number of figures, and for the color versions of the figures for the electronic versions of the books. A special thanks goes out to Laura Robbins for working with me on the color and design standards early in the process. Also, thanks to Mike Tanamachi for drawing all the figures so well (and then redrawing them every time I changed my mind about something).

Thanks to Chris Burns of CertSkills for all the work on the mind maps, both those used in the final product and those used to build the book, as well as for being a bit of a test case for some of the chapters.

A special thank you to you readers who write in with suggestions, possible errors, and especially those of you who post online at the Cisco Learning Network. Without question, the comments I receive directly and overhear by participating at CLN made this edition a better book.

Thanks to my wife, Kris. Book schedules have a bigger impact than I would like, but you always make it work. Thanks to my daughter, Hannah, for all the great study/work breaks on some of these busy schooldays. And thanks to Jesus Christ, for this opportunity to write.

## Contents at a Glance

Introduction xxvi

Getting Started 3

### Part I: LAN Switching 9

Chapter 1: Spanning Tree Protocol Concepts 10

Chapter 2: Spanning Tree Protocol Implementation 36

Chapter 3: Troubleshooting LAN Switching 64

Part I Review 104

### Part II: IP Version 4 Routing 109

Chapter 4: Troubleshooting IPv4 Routing Part I 110

Chapter 5: Troubleshooting IPv4 Routing Part II 132

Chapter 6: Creating Redundant First-Hop Routers 156

Chapter 7: Virtual Private Networks 176

Part II Review 194

### Part III: IP Version 4 Routing Protocols 199

Chapter 8: Implementing OSPF for IPv4 200

Chapter 9: Understanding EIGRP Concepts 230

Chapter 10: Implementing EIGRP for IPv4 252

Chapter 11: Troubleshooting IPv4 Routing Protocols 278

Part III Review 304

### Part IV: Wide Area Networks 309

Chapter 12: Implementing Point-to-Point WANs 310

Chapter 13: Understanding Frame Relay Concepts 336

Chapter 14: Implementing Frame Relay 352

Chapter 15: Identifying Other Types of WANs 386

Part IV Review 404

### Part V: IP Version 6 409

Chapter 16: Troubleshooting IPv6 Routing 410

Chapter 17: Implementing OSPF for IPv6 434

Chapter 18: Implementing EIGRP for IPv6 460

Part V Review 480

**Part VI: Network Management 485**

Chapter 19: Managing Network Devices 486

Chapter 20: Managing IOS Files 504

Chapter 21: Managing IOS Licensing 526

Part VI Review 542

**Part VII: Final Review 545**

Chapter 22: Final Review 546

**Part VIII: Appendixes 561**

Appendix A: Numeric Reference Tables 563

Appendix B: ICND2 Exam Updates 571

Glossary 572

Index 592

**DVD Appendixes**

Appendix C Answers to the Review Questions

Appendix D Memory Tables

Appendix E Memory Tables Answer Key

Appendix F Mind Map Solutions

Appendix G Study Planner

# Contents

Introduction	xxvi
Getting Started	3

## Part I: LAN Switching 9

### Chapter 1 Spanning Tree Protocol Concepts 10

Foundation Topics	11
LAN Switching Review	11
LAN Switch Forwarding Logic	11
Switch Verification	12
<i>Viewing the MAC Address Table</i>	12
<i>Determining the VLAN of a Frame</i>	13
<i>Verifying Trunks</i>	15
Spanning Tree Protocol (IEEE 802.1D)	15
The Need for Spanning Tree	16
What IEEE 802.1D Spanning Tree Does	18
How Spanning Tree Works	19
<i>The STP Bridge ID and Hello BPDU</i>	20
<i>Electing the Root Switch</i>	21
<i>Choosing Each Switch's Root Port</i>	23
<i>Choosing the Designated Port on Each LAN Segment</i>	24
Influencing and Changing the STP Topology	25
<i>Making Configuration Changes to Influence the STP Topology</i>	25
<i>Reacting to State Changes That Affect the STP Topology</i>	26
<i>How Switches React to Changes with STP</i>	26
<i>Changing Interface States with STP</i>	28
Optional STP Features	29
EtherChannel	29
PortFast	30
BPDU Guard	30
Rapid STP (IEEE 802.1w)	31
Review Activities	32

### Chapter 2 Spanning Tree Protocol Implementation 36

Foundation Topics	37
STP Configuration and Verification	37
Setting the STP Mode	37
Connecting STP Concepts to STP Configuration Options	38
<i>Per-VLAN Configuration Settings</i>	38
<i>The Bridge ID and System ID Extension</i>	39

<i>Per-VLAN Port Costs</i>	40
<i>STP Configuration Option Summary</i>	40
Verifying STP Operation	40
Configuring STP Port Costs	43
Configuring Priority to Influence the Root Election	45
Configuring PortFast and BPDU Guard	46
Configuring EtherChannel	47
<i>Configuring a Manual EtherChannel</i>	48
<i>Configuring Dynamic EtherChannels</i>	50
STP Troubleshooting	50
Determining the Root Switch	51
Determining the Root Port on Nonroot Switches	52
<i>STP Tiebreakers When Choosing the Root Port</i>	53
<i>Suggestions for Attacking Root Port Problems on the Exam</i>	54
Determining the Designated Port on Each LAN Segment	54
<i>Suggestions for Attacking Designated Port Problems on the Exam</i>	55
STP Convergence	56
Troubleshooting EtherChannel	56
<i>Incorrect Options on the channel-group Command</i>	57
<i>Configuration Checks Before Adding Interfaces to EtherChannels</i>	58
Review Activities	60

### **Chapter 3 Troubleshooting LAN Switching 64**

Foundation Topics	65
Generalized Troubleshooting Methodologies	65
Analyzing and Predicting Normal Network Operation	65
<i>Data Plane Analysis</i>	66
<i>Control Plane Analysis</i>	67
<i>Predicting Normal Operations: Summary of the Process</i>	68
Problem Isolation	68
Root Cause Analysis	69
Real World Versus the Exams	70
Troubleshooting the LAN Switching Data Plane	70
An Overview of the Normal LAN Switch Forwarding Process	71
Step 1: Confirm the Network Diagrams Using CDP	72
Step 2: Isolate Interface Problems	73
<i>Interface Status Codes and Reasons for Nonworking States</i>	74
<i>The notconnect State and Cabling Pinouts</i>	75
<i>Determining Switch Interface Speed and Duplex</i>	76
<i>Issues Related to Speed and Duplex</i>	77
Step 3: Isolate Filtering and Port Security Problems	79

Step 4: Isolate VLAN and Trunking Problems	82
<i>Ensuring That the Right Access Interfaces Are in the Right VLANs</i>	83
<i>Access VLANs Not Being Defined or Not Being Active</i>	83
<i>Identify Trunks and VLANs Forwarded on Those Trunks</i>	84
Troubleshooting Examples and Exercises	86
Troubleshooting Example 1: Find Existing LAN Data Plane Problems	86
<i>Step 1: Verify the Accuracy of the Diagram Using CDP</i>	87
<i>Step 2: Check for Interface Problems</i>	88
<i>Step 3: Check for Port Security Problems</i>	90
<i>Step 4: Check for VLAN and VLAN Trunk Problems</i>	91
Troubleshooting Example 2: Predicting LAN Data Plane Behavior	94
<i>PC1 ARP Request (Broadcast)</i>	95
<i>R1 ARP Reply (Unicast)</i>	98
Review Activities	102

## **Part I Review 104**

## **Part II: IP Version 4 Routing 109**

### **Chapter 4 Troubleshooting IPv4 Routing Part I 110**

Foundation Topics	111
Predicting Normal IPv4 Routing Behavior	111
Host IPv4 Routing Logic	111
Routing Logic Used by IPv4 Routers	112
<i>IP Routing Logic on a Single Router</i>	112
<i>IP Routing from Host to Host</i>	113
<i>Building New Data Link Headers Using ARP Information</i>	114
Problem Isolation Using the ping Command	115
Ping Command Basics	115
Strategies and Results When Testing with the ping Command	116
<i>Testing Longer Routes from Near the Source of the Problem</i>	117
<i>Using Extended Ping to Test the Reverse Route</i>	119
<i>Testing LAN Neighbors with Standard Ping</i>	121
<i>Testing LAN Neighbors with Extended Ping</i>	122
<i>Testing WAN Neighbors with Standard Ping</i>	122
Using Ping with Names and with IP Addresses	123
Problem Isolation Using the traceroute Command	124
traceroute Basics	124
<i>How the traceroute Command Works</i>	125
<i>Standard and Extended traceroute</i>	126
Using traceroute to Isolate the Problem to Two Routers	127
Review Activities	130

**Chapter 5 Troubleshooting IPv4 Routing Part II 132**

Foundation Topics	133
Problems Between the Host and the Default Router	133
Root Causes Based on a Host's IPv4 Settings	133
<i>Ensure IPv4 Settings Correctly Match</i>	133
<i>Mismatched Masks Impact Route to Reach Subnet</i>	134
<i>Typical Root Causes of DNS Problems</i>	136
<i>Wrong Default Router IP Address Setting</i>	137
Root Causes Based on the Default Router's Configuration	137
<i>Mismatched VLAN Trunking Configuration with Router on a Stick</i>	138
<i>DHCP Relay Issues</i>	140
<i>Router LAN Interface and LAN Issues</i>	141
Problems with Routing Packets Between Routers	143
IP Forwarding by Matching the Most Specific Route	143
<i>Using show ip route and Subnet Math to Find the Best Route</i>	144
<i>Using show ip route address to Find the Best Route</i>	145
<i>show ip route Reference</i>	145
Routing Problems Caused by Incorrect Addressing Plans	146
<i>Recognizing When VLSM Is Used or Not</i>	147
<i>Overlaps When Not Using VLSM</i>	147
<i>Overlaps When Using VLSM</i>	148
<i>Configuring Overlapping VLSM Subnets</i>	149
Router WAN Interface Status	150
Filtering Packets with Access Lists	151
Review Activities	153

**Chapter 6 Creating Redundant First-Hop Routers 156**

Foundation Topics	157
FHRP Concepts	157
The Need for Redundancy in Networks	157
The Need for a First Hop Redundancy Protocol	159
The Three Solutions for First-Hop Redundancy	160
HSRP Concepts	160
<i>HSRP Failover</i>	161
<i>HSRP Load Balancing</i>	162
GLBP Concepts	163
FHRP Configuration and Verification	164
Configuring and Verifying HSRP	164
Configuring and Verifying GLBP	167
Review Activities	170



**Chapter 7 Virtual Private Networks 176**

- Foundation Topics 177
- VPN Fundamentals 177
  - IPsec VPNs 179
  - SSL VPNs 181
- GRE Tunnels 181
  - GRE Tunnel Concepts 182
  - Routing over GRE Tunnels* 182
  - GRE Tunnels over the Unsecured Network* 183
  - Configuring GRE Tunnels 185
  - Verifying a GRE Tunnel 187
- Review Activities 190

**Part II Review 194****Part III: IP Version 4 Routing Protocols 199****Chapter 8 Implementing OSPF for IPv4 200**

- Foundation Topics 201
- OSPF Protocols and Operation 201
  - OSPF Overview 201
  - Becoming Neighbors and Exchanging the LSDB 202
    - Agreeing to Become Neighbors* 202
    - Fully Exchanging LSAs with Neighbors* 203
    - Maintaining Neighbors and the LSDB* 204
    - Using Designated Routers on Ethernet Links* 205
  - Scaling OSPF Using Areas 206
    - OSPF Areas* 207
    - How Areas Reduce SPF Calculation Time* 208
    - OSPF Area Design Advantages* 209
  - Link-State Advertisements 209
    - Router LSAs Build Most of the Intra-Area Topology* 210
    - Network LSAs Complete the Intra-Area Topology* 211
    - LSAs in a Multi-Area Design* 212
  - Calculating the Best Routes with SPF 214
    - Administrative Distance 215
- OSPF Configuration and Verification 216
  - OSPFv2 Configuration Overview 216
  - Multi-Area OSPFv2 Configuration Example 217
    - Single-Area Configurations* 218
    - Multi-Area Configuration* 219
  - Verifying the Multi-Area Configuration 220
    - Verifying the Correct Areas on Each Interface on an ABR* 221
    - Verifying Which Router Is DR and BDR* 221

<i>Verifying the Number and Type of LSAs</i>	222
<i>Verifying OSPF Routes</i>	223
OSPF Metrics (Cost)	223
<i>Setting the Cost Based on Interface Bandwidth</i>	224
<i>The Need for a Higher Reference Bandwidth</i>	225
OSPF Load Balancing	225
Review Activities	226

## **Chapter 9 Understanding EIGRP Concepts 230**

Foundation Topics	231
EIGRP and Distance Vector Routing Protocols	231
Introduction to EIGRP	231
Basic Distance Vector Routing Protocol Features	233
<i>The Concept of a Distance and a Vector</i>	233
<i>Full Update Messages and Split Horizon</i>	234
<i>Route Poisoning</i>	236
EIGRP as an Advanced DV Protocol	237
<i>EIGRP Sends Partial Update Messages, As Needed</i>	237
<i>EIGRP Maintains Neighbor Status Using Hello</i>	237
<i>Summary of Interior Routing Protocol Features</i>	238
EIGRP Concepts and Operation	239
EIGRP Neighbors	239
Exchanging EIGRP Topology Information	240
Calculating the Best Routes for the Routing Table	241
<i>The EIGRP Metric Calculation</i>	241
<i>An Example of Calculated EIGRP Metrics</i>	242
<i>Caveats with Bandwidth on Serial Links</i>	243
EIGRP Convergence	244
<i>Feasible Distance and Reported Distance</i>	244
<i>EIGRP Successors and Feasible Successors</i>	245
<i>The Query and Reply Process</i>	246
Review Activities	248

## **Chapter 10 Implementing EIGRP for IPv4 252**

Foundation Topics	253
Core EIGRP Configuration and Verification	253
EIGRP Configuration	253
Configuring EIGRP Using a Wildcard Mask	255
Verifying EIGRP Core Features	255
<i>Finding the Interfaces on Which EIGRP Is Enabled</i>	256
<i>Displaying EIGRP Neighbor Status</i>	258
<i>Displaying the IPv4 Routing Table</i>	259

EIGRP Metrics, Successors, and Feasible Successors	260
Viewing the EIGRP Topology Table	261
<i>Finding Successor Routes</i>	262
<i>Finding Feasible Successor Routes</i>	263
<i>Convergence Using the Feasible Successor Route</i>	265
Examining the Metric Components	266
Other EIGRP Configuration Settings	267
Load Balancing Across Multiple EIGRP Routes	267
Tuning the EIGRP Metric Calculation	269
Autosummarization and Discontiguous Classful Networks	270
<i>Automatic Summarization at the Boundary of a Classful Network</i>	270
<i>Discontiguous Classful Networks</i>	271
Review Activities	273

## **Chapter 11 Troubleshooting IPv4 Routing Protocols 278**

Foundation Topics	279
Perspectives on Troubleshooting Routing Protocol Problems	279
Interfaces Enabled with a Routing Protocol	280
EIGRP Interface Troubleshooting	281
<i>Examining Working EIGRP Interfaces</i>	282
<i>Examining the Problems with EIGRP Interfaces</i>	284
OSPF Interface Troubleshooting	286
Neighbor Relationships	289
EIGRP Neighbor Verification Checks	290
EIGRP Neighbor Troubleshooting Example	291
OSPF Neighbor Troubleshooting	293
<i>Finding Area Mismatches</i>	294
<i>Finding Duplicate OSPF Router IDs</i>	295
<i>Finding OSPF Hello and Dead Timer Mismatches</i>	296
Other OSPF Issues	297
<i>Mismatched OSPF Network Types</i>	297
<i>Mismatched MTU Settings</i>	299
Review Activities	300

## **Part III Review 304**

## **Part IV: Wide-Area Networks 309**

### **Chapter 12 Implementing Point-to-Point WANs 310**

Foundation Topics	311
Leased Line WANs with HDLC	311
Layer 1 Leased Lines	311
<i>The Physical Components of a Leased Line</i>	312
<i>Leased Lines and the T-Carrier System</i>	314

<i>The Role of the CSU/DSU</i>	315
<i>Building a WAN Link in a Lab</i>	315
Layer 2 Leased Lines with HDLC	316
Configuring HDLC	317
Leased-Line WANs with PPP	320
PPP Concepts	320
<i>PPP Framing</i>	321
<i>PPP Control Protocols</i>	321
<i>PPP Authentication</i>	322
Configuring PPP	323
CHAP Configuration and Verification	324
Troubleshooting Serial Links	325
Troubleshooting Layer 1 Problems	325
Troubleshooting Layer 2 Problems	326
<i>Keepalive Failure</i>	327
<i>PAP and CHAP Authentication Failure</i>	328
Troubleshooting Layer 3 Problems	329
Review Activities	331
<b>Chapter 13 Understanding Frame Relay Concepts</b>	<b>336</b>
Foundation Topics	337
Frame Relay Overview	337
Virtual Circuits	339
LMI and Encapsulation Types	340
Frame Relay Encapsulation and Framing	341
Frame Relay Addressing	342
Frame Relay Local Addressing	342
Frame Forwarding with One DLCI Field	343
Network Layer Addressing with Frame Relay	344
Frame Relay Layer 3 Addressing: One Subnet Containing All Frame Relay DTEs	345
Frame Relay Layer 3 Addressing: One Subnet Per VC	345
Frame Relay Layer 3 Addressing: Hybrid Approach	347
Review Activities	349
<b>Chapter 14 Implementing Frame Relay</b>	<b>352</b>
Foundation Topics	353
Frame Relay Configuration and Verification	353
Planning a Frame Relay Configuration	353
Configuring Using Physical Interfaces and One IP Subnet	354
Configuring the Encapsulation and LMI	356

Frame Relay Address Mapping	357
<i>Inverse ARP</i>	360
<i>Static Frame Relay Mapping</i>	360
Configuring Point-to-Point Subinterfaces	361
Verifying Point-to-Point Frame Relay	364
Configuring with Multipoint Subinterfaces	366
OSPF Issues on Frame Relay Multipoint and Physical Interfaces	368
Frame Relay Troubleshooting	369
A Suggested Frame Relay Troubleshooting Process	369
Layer 1 Issues on the Access Link (Step 1)	370
Layer 2 Issues on the Access Link (Step 2)	371
PVC Problems and Status (Step 3)	372
<i>Find the Connected Subnet and Outgoing Interface (Steps 3a and 3b)</i>	373
<i>Find the PVCs Assigned to That Interface (Step 3c)</i>	374
<i>Determine Which PVC Is Used to Reach a Particular Neighbor (Step 3d)</i>	375
PVC Status	375
Subinterface Status	377
Frame Relay Mapping Issues (Step 4)	377
End-to-End Encapsulation (Step 5)	378
Mismatched Subnet Numbers (Step 6)	379
Review Activities	380
<b>Chapter 15 Identifying Other Types of WANs</b>	<b>386</b>
Foundation Topics	387
Private WANs to Connect Enterprises	387
Leased Lines	387
Frame Relay	388
Ethernet WANs	389
MPLS	390
VSAT	391
Public WANs and Internet Access	392
Internet Access (WAN) Links	392
Dial Access with Modems and ISDN	393
Digital Subscriber Line	395
Cable Internet	396
Mobile Phone Access with 3G/4G	397
PPP over Ethernet	398
<i>PPP over Ethernet Concepts</i>	398
<i>PPP over Ethernet Configuration</i>	399
Review Activities	401
<b>Part IV Review</b>	<b>404</b>

## **Part V: IP Version 6 409**

### **Chapter 16 Troubleshooting IPv6 Routing 410**

Foundation Topics	411
Normal IPv6 Operation	411
Unicast IPv6 Addresses and IPv6 Subnetting	411
Assigning Addresses to Hosts	413
<i>Stateful DHCPv6</i>	413
<i>Stateless Address Autoconfiguration</i>	414
<i>Router Address and Static Route Configuration</i>	415
<i>Configuring IPv6 Routing and Addresses on Routers</i>	415
<i>IPv6 Static Routes on Routers</i>	416
Verifying IPv6 Connectivity	417
<i>Verifying Connectivity from IPv6 Hosts</i>	417
<i>Verifying IPv6 from Routers</i>	419
Troubleshooting IPv6	421
Pings from the Host Work Only in Some Cases	421
Pings Fail from a Host to Its Default Router	423
Problems Using Any Function That Requires DNS	424
Host Is Missing IPv6 Settings: Stateful DHCP Issues	424
Host Is Missing IPv6 Settings: SLAAC Issues	425
Traceroute Shows Some Hops, But Fails	427
Routing Looks Good, But Traceroute Still Fails	428
Review Activities	430

### **Chapter 17 Implementing OSPF for IPv6 434**

Foundation Topics	435
OSPFv3 Configuration	435
OSPFv3 ICND1 Configuration Review	435
Example Multi-Area OSPFv3 Configuration	435
<i>Single Area Configuration on the Three Internal Routers</i>	436
<i>Adding Multi-Area Configuration on the Area Border Router</i>	438
Other OSPFv3 Configuration Settings	439
<i>Setting OSPFv3 Interface Cost to Influence Route Selection</i>	439
<i>OSPF Load Balancing</i>	440
<i>Injecting Default Routes</i>	440
OSPF Concepts, Verification, and Troubleshooting	441
OSPFv3 Interfaces	443
<i>Verifying OSPFv3 Interfaces</i>	443
<i>Troubleshooting OSPFv3 Interfaces</i>	443
OSPFv3 Neighbors	445
<i>Verifying OSPFv3 Neighbors</i>	445
<i>Troubleshooting OSPFv3 Neighbors</i>	446

OSPFv3 LSDB and LSAs	448
<i>Verifying OSPFv3 LSAs</i>	448
<i>Troubleshooting OSPFv3 LSAs</i>	450
OSPFv3 Metrics and IPv6 Routes	451
<i>Verifying OSPFv3 Interface Cost and Metrics</i>	451
<i>Troubleshooting IPv6 Routes Added by OSPFv3</i>	453
Review Activities	455

## **Chapter 18 Implementing EIGRP for IPv6 460**

Foundation Topics	461
EIGRPv6 Configuration	461
EIGRPv6 Configuration Basics	461
EIGRPv6 Configuration Example	462
Other EIGRPv6 Configuration Settings	464
<i>Setting Bandwidth and Delay to Influence EIGRPv6 Route Selection</i>	464
<i>EIGRP Load Balancing</i>	465
<i>EIGRP Timers</i>	466
EIGRPv6 Concepts, Verification, and Troubleshooting	466
EIGRPv6 Interfaces	467
EIGRPv6 Neighbors	469
EIGRPv6 Topology Database	470
EIGRPv6 IPv6 Routes	472
Review Activities	474

## **Part V Review 480**

## **Part VI: Network Management 485**

### **Chapter 19 Managing Network Devices 486**

Foundation Topics	487
Simple Network Management Protocol	487
Describing SNMP	487
The Management Information Base	488
Configuring SNMP Version 2c	490
SNMP Version 3	491
System Message Logging (Syslog)	492
An Overview of System Message Logging	492
System Message Format	493
System Message Severity Levels	494
Configuring and Verifying Syslog	494
Using a Syslog Server	495
NetFlow	495
An Overview of NetFlow	496
Network Flows	497
Configuring NetFlow	497

Verifying and Using NetFlow	498
The NetFlow Collector	500
Review Activities	501

## **Chapter 20 Managing IOS Files 504**

Foundation Topics	505
Managing Cisco IOS Files	505
Upgrading a Cisco IOS Software Image into Flash Memory	505
The Cisco IOS Software Boot Sequence	507
<i>The Three Router Operating Systems</i>	508
<i>The Configuration Register</i>	509
<i>How a Router Chooses Which OS to Load</i>	509
<i>Recovering If the IOS Does Not Load</i>	511
<i>Verifying the IOS Image Using the show version Command</i>	512
Password Recovery	513
The General Ideas Behind Cisco Password Recovery/Reset	514
A Specific Password Reset Example	515
Managing Configuration Files	517
Configuration File Basics	517
Copying and Erasing Configuration Files	519
Initial Configuration (Setup Mode)	521
Review Activities	522

## **Chapter 21 Managing IOS Licensing 526**

Foundation Topics	527
IOS Packaging	527
IOS Images per Model, Series, and per Software Version/Release	527
Original Packaging: One IOS Image per Feature Set Combination	528
New IOS Packaging: One Universal Image with All Feature Sets	528
IOS Software Activation with Universal Images	529
Managing Software Activation with Cisco License Manager	530
Manually Activating Software Using Licenses	531
Example of Manually Activating a License	533
<i>Showing the Current License Status</i>	533
<i>Adding a Permanent Technology Package License</i>	535
Right-to-Use Licenses	536
Review Activities	539

## **Part VI Review 542**



**Part VII: Final Review 545****Chapter 22 Final Review 546**

- Advice About the Exam Event 546
  - Learn the Question Types Using the Cisco Certification Exam Tutorial 546
  - Think About Your Time Budget Versus Numbers of Questions 547
  - A Suggested Time-Check Method 548
  - Miscellaneous Pre-Exam Suggestions 548
  - Exam-Day Advice 548
- Exam Review 549
  - Practice Subnetting and Other Math-Related Skills 549
  - Take Practice Exams 551
    - Practicing Taking the ICND2 Exam* 551
    - Practicing Taking the CCNA Exam* 552
    - Advice on How to Answer Exam Questions* 553
  - Find Knowledge Gaps Through Question Review 554
  - Practice Hands-On CLI Skills 556
    - Review Mind Maps from Part Review* 557
    - Do Labs* 557
  - Other Study Tasks 558
  - Final Thoughts 558

**Part VIII: Appendixes 561**

- Appendix A** Numeric Reference Tables 563
- Appendix B** ICND2 Exam Updates 571
  - Glossary 572
  - Index 592

**DVD-Only Appendixes**

- Appendix C** Answers to the Review Questions
- Appendix D** Memory Tables
- Appendix E** Memory Tables Answer Key
- Appendix F** Mind Map Solutions
- Appendix G** Study Planner

## Icons Used in This Book



Printer



PC



Laptop



Server



Phone



IP Phone



Router



Switch



Frame Relay Switch



Cable Modem



Access Point



ASA



DSLAM



WAN Switch



CSU/DSU



Hub



PIX Firewall



Bridge



Layer 3 Switch



Network Cloud



Ethernet Connection



Serial Line



Virtual Circuit



Ethernet WAN



Wireless

## Command Syntax Conventions

The conventions used to present command syntax in this book are the same conventions used in the IOS Command Reference. The Command Reference describes these conventions as follows:

- **Boldface** indicates commands and keywords that are entered literally as shown. In actual configuration examples and output (not general command syntax), boldface indicates commands that are manually input by the user (such as a **show** command).
- *Italic* indicates arguments for which you supply actual values.
- Vertical bars (|) separate alternative, mutually exclusive elements.
- Square brackets ( [ ] ) indicate an optional element.
- Braces ( { } ) indicate a required choice.
- Braces within brackets ( { [ ] } ) indicate a required choice within an optional element.

# Introduction

## About the Book and the Exams

This book serves first as a textbook in some college networking courses. At the same time, you might want a career in networking somewhere down the road, and this book helps you with a big step in that journey by helping you pass a Cisco certification exam.

If you want to succeed as a technical person in the networking industry at all, you need to know Cisco. Cisco has a ridiculously high market share in the router and switch marketplace, with more than 80 percent market share in some markets. In many geographies and markets around the world, networking equals Cisco. If you want to be taken seriously as a network engineer, Cisco certification makes perfect sense.

## The Exams That Help You Achieve CCENT and CCNA

Cisco announced changes to the CCENT and CCNA Routing and Switching certifications, and the related 100-101 ICND1, 200-101 ICND2, and 200-120 CCNA exams, early in the year 2013. For those of you who understand how the old Cisco ICND1, ICND2, and CCNA exams worked, the structure remains the same. For those of you new to Cisco certifications, this introduction begins by introducing the basics.

Most everyone new to Cisco certifications begins with either CCENT or CCNA Routing and Switching. CCENT certification requires knowledge and skills on about half as much material as does CCNA Routing and Switching, so CCENT is the easier first step.

The CCENT certification requires a single step: pass the ICND1 exam. Simple enough.

The CCNA Routing and Switching certification gives you two options, as shown in Figure I-1: pass both the ICND1 and ICND2 exams, or just pass the CCNA exam. (Note that there is no separate certification for passing the ICND2 exam.)

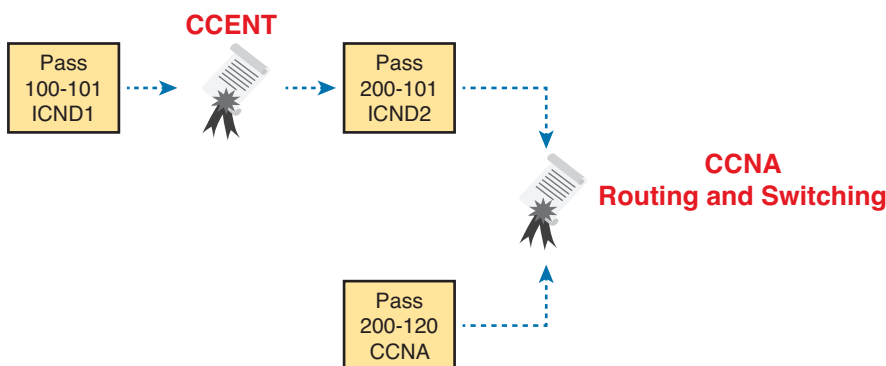

**Figure I-1** Cisco Entry-Level Certifications and Exams

As you can see, although you can obtain the CCENT certification by taking the ICND1 exam, you do not have to be CCENT certified before you get your CCNA Routing and Switching certification. You can choose to take the CCNA exam and bypass the CCENT certification.

As for the topics themselves, the ICND1 and ICND2 exams cover different topics (but with some overlap required). For example, ICND1 covers the basics of the Open Shortest Path First (OSPF) routing protocol. ICND2 covers more detail about OSPF, but to discuss those additional details,

ICND2 must rely on the parts of OSPF included in ICND1. Many topics in ICND2 build on topics in ICND1, causing some overlap.

The CCNA exam covers all the topics in both ICND1 and ICND2, no more, no less.

## Types of Questions on the Exams

The ICND1, ICND2, and CCNA exams all follow the same general format. At the testing center, you sit in a quiet room with a PC. Before the exam timer begins, you have a chance to do a few other tasks on the PC; for instance, you can take a sample quiz just to get accustomed to the PC and the testing engine. Anyone who has user-level skills in getting around a PC should have no problems with the testing environment.

Once the exam starts, the screen shows you question after question. The questions usually fall into one of the following categories:

- Multiple choice, single answer
- Multiple choice, multiple answer
- Testlet
- Drag-and-drop
- Simulated lab (sim)
- Simlet

The first three items in the list are all multiple choice questions. The multiple choice format simply requires that you point and click a circle beside the correct answer(s). Cisco traditionally tells you how many answers you need to choose, and the testing software prevents you from choosing too many answers. The testlet style gives you one larger scenario statement, with multiple different multiple choice questions about that one scenario.

Drag-and-drop questions require you to move some items around on the GUI. You left-click and hold, move a button or icon to another area, and release the clicker to place the object somewhere else—usually into a list. So, for some questions, to answer the question correctly, you might need to put a list of five things in the proper order.

The last two types both use a network simulator to ask questions. Interestingly, the two types actually allow Cisco to assess two very different skills. First, sim questions generally describe a problem, and your task is to configure one or more routers and switches to fix the problem. The exam then grades the question based on the configuration you changed or added.

The simlet questions may well be the most difficult style of question on the exams. Simlet questions also use a network simulator, but instead of you answering the question by changing the configuration, the question includes one or more multiple choice questions. The questions require that you use the simulator to examine the current behavior of a network, interpreting the output of any **show** commands that you can remember to answer the question. Whereas sim questions require you to troubleshoot problems related to a configuration, simlets require you to both analyze both working and broken networks, correlating **show** command output with your knowledge of networking theory and configuration commands.

You can watch and even experiment with these command types using the Cisco Exam Tutorial. To find the Cisco Certification Exam Tutorial, go to <http://www.cisco.com> and search for “exam tutorial.”

## What’s on the CCNA Exams?

Ever since I was in grade school, whenever the teacher announced that we were having a test soon, someone would always ask, “What’s on the test?” Even in college, people would try to get

more information about what would be on the exams. At heart, the goal is to know what to study hard, what to study a little, and what to not study at all.

Cisco tells the world the topics on each of their exams. Cisco wants the public to know both the variety of topics, and an idea about the kinds of knowledge and skills required for each topic, for every Cisco certification exam. To that end, Cisco publishes a set of exam topics for each exam.

Many Cisco exam topics list both a networking topic plus an important verb. The verb tells us to what degree the topic must be understood and what skills are required. The topic also implies the kinds of skills required for that topic. For example, one topic might start with “Describe...,” another with “Configure...,” another with “Verify...,” and another might begin with “Troubleshoot...” That last topic has the highest required skill level, because to troubleshoot you must understand the topic, be able to configure it (to see what’s wrong with the configuration), and verify it (to find the root cause of the problem). By listing the topics and skill level, Cisco helps us all prepare for its exams. Although the exam topics are helpful, keep in mind that Cisco adds a disclaimer that the posted exam topics for all of its certification exams are *guidelines*. Cisco makes the effort to keep the exam questions within the confines of the stated exam topics, and I know from talking to those involved that every question is analyzed for whether it fits within the stated exam topics.

### ICND1 Exam Topics

Tables I-1 through I-7 lists the exam topics for the ICND1 exam. Following those tables, Tables I-8 through I-12 list the exam topics for ICND2. These tables note the book chapters in which each exam topic is covered.

Note that the tables follow Cisco’s organization of topics, by both grouping similar topics and listing sub-topics. The subtopics simply give more specific terms and concepts to provide more detail about some exam topics. The tables show the main topics in bold and the subtopics as indented text inside the tables.

**Table I-1** ICND1 Exam Topics: Operation of IP Data Networks

Chapter	Operation of IP Data Networks
1–4, 6, 15	<b>Recognize the purpose and functions of various network devices such as Routers, Switches, Bridges and Hubs.</b>
1–4, 6, 15	<b>Select the components required to meet a given network specification.</b>
5	<b>Identify common applications and their impact on the network</b>
1	<b>Describe the purpose and basic operation of the protocols in the OSI and TCP/IP models.</b>
2–5, 6, 9, 16, 24, 25	<b>Predict the data flow between two hosts across a network.</b>
2, 6, 15	<b>Identify the appropriate media, cables, ports, and connectors to connect Cisco network devices to other network devices and hosts in a LAN</b>

**Table I-2** ICND1 Exam Topics: LAN Switching Technologies

Chapter	LAN Switching Technologies
2, 6	<b>Determine the technology and media access control method for Ethernet networks</b>
6, 8, 9	<b>Identify basic switching concepts and the operation of Cisco switches.</b>
6, 8	Collision Domains

Chapter	LAN Switching Technologies
6, 9	Broadcast Domains
6	Types of switching
6, 8, 9	CAM Table
7	Configure and verify initial switch configuration including remote access management.
7	Cisco IOS commands to perform basic switch setup
7, 18, 28	Verify network status and switch operation using basic utilities such as ping, telnet and ssh.
9	Describe how VLANs create logically separate networks and the need for routing between them.
9	Explain network segmentation and basic traffic management concepts
9	Configure and verify VLANs
9, 10	Configure and verify trunking on Cisco switches
9, 10	DTP
10	Auto negotiation

**Table I-3** ICND1 Exam Topics: IP Addressing (IPv4/IPv6)

Chapter	IP Addressing (IPv4/IPv6)
11	Describe the operation and necessity of using private and public IP addresses for IPv4 addressing
25, 26	Identify the appropriate IPv6 addressing scheme to satisfy addressing requirements in a LAN/WAN environment.
11, 19, 20, 21	Identify the appropriate IPv4 addressing scheme using VLSM and summarization to satisfy addressing requirements in a LAN/WAN environment.
27, 28, 29	Describe the technological requirements for running IPv6 in conjunction with IPv4 such as dual stack
25–28	Describe IPv6 addresses
25, 26	Global unicast
27	Multicast
27	Link local
26	Unique local
27	eui 64
28	autoconfiguration

**Table I-4** ICND1 Exam Topics: IP Routing Technologies

Chapter	IP Routing Technologies
16	Describe basic routing concepts
16	CEF
16	Packet forwarding
16	Router lookup process
15–18, 27	<b>Configure and verify utilizing the CLI to set basic Router configuration</b>
16–18, 27	Cisco IOS commands to perform basic router setup
16, 27	<b>Configure and verify operation status of an ethernet interface</b>
16–18, 27–29	<b>Verify router configuration and network connectivity</b>
16–18, 27, 29	Cisco IOS commands to review basic router information and network connectivity
16, 29	<b>Configure and verify routing configuration for a static or default route given specific routing requirements</b>
4, 16, 17, 25, 29	<b>Differentiate methods of routing and routing protocols</b>
4, 17, 29	Static vs. Dynamic
17	Link state vs. Distance Vector
16, 25	next hop
16, 25	ip routing table
17, 29	Passive interfaces
17, 29	<b>Configure and verify OSPF (single area)</b>
17, 29	Benefit of single area
17	Configure OSPF v2
29	Configure OSPF v3
17, 29	Router ID
17, 29	Passive interface
16	<b>Configure and verify interVLAN routing (Router on a stick)</b>
16	sub interfaces
16	upstream routing
16	encapsulation
8, 16	<b>Configure SVI interfaces</b>

**Table I-5** ICND1 Exam Topics: IP Services

Chapter	IP Services
18, 28	<b>Configure and verify DHCP (IOS Router)</b>
18, 28	configuring router interfaces to use DHCP
18	DHCP options
18	excluded addresses



Chapter	IP Services
18	lease time
22, 23	<b>Describe the types, features, and applications of ACLs</b>
22	Standard
23	Sequence numbers
23	Editing
23	Extended
23	Named
22, 23	Numbered
22	Log option
22, 23	<b>Configure and verify ACLs in a network environment</b>
23	Named
22, 23	Numbered
22	Log option
24	<b>Identify the basic operation of NAT</b>
24	Purpose
24	Pool
24	Static
24	1 to 1
24	Overloading
24	Source addressing
24	One way NAT
24	<b>Configure and verify NAT for given network requirements</b>
23	<b>Configure and verify NTP as a client</b>

**Table I-6** ICND1 Exam Topics: Network Device Security

Chapter	Network Device Security
8, 15	<b>Configure and verify network device security features such as</b>
8, 15	Device password security
8, 15	Enable secret vs enable
23	Transport
23	Disable telnet
8	SSH
8	VTYs
23	Physical security
8	Service password
8	Describe external authentication methods

Chapter	Network Device Security
8, 10	<b>Configure and verify Switch Port Security features such as</b>
8	Sticky MAC
8	MAC address limitation
8, 10	Static / dynamic
8, 10	Violation modes
8, 10	Err disable
8, 10	Shutdown
8, 10	Protect restrict
8	Shutdown unused ports
8	Err disable recovery
8	Assign unused ports to an unused VLAN
23	Setting native VLAN to other than VLAN 1
22, 23	<b>Configure and verify ACLs to filter network traffic</b>
23	<b>Configure and verify an ACLs to limit telnet and SSH access to the router</b>

**Table I-7** ICND1 Exam Topics: Troubleshooting

Chapter	Troubleshooting
12–15, 18–21, 25–28	<b>Troubleshoot and correct common problems associated with IP addressing and host configurations.</b>
9, 10	<b>Troubleshoot and Resolve VLAN problems</b>
9, 10	identify that VLANs are configured
9, 10	port membership correct
9, 10	IP address configured
9, 10	<b>Troubleshoot and Resolve trunking problems on Cisco switches</b>
9, 10	correct trunk states
9, 10	correct encapsulation configured
9, 10	correct vlans allowed
22, 23	<b>Troubleshoot and Resolve ACL issues</b>
22, 23	Statistics
22, 23	Permitted networks
22, 23	Direction
22, 23	Interface
10	<b>Troubleshoot and Resolve Layer 1 problems</b>
10	Framing
10	CRC
10	Runts

Chapter	Troubleshooting
10	Giants
10	Dropped packets
10	Late collision
10	Input / Output errors

### ICND2 Exam Topics

Tables I-8 through I-12 list the exam topics for ICND2. These tables note the book chapters in which each exam topic is covered. Note that each table covers a main exam topic. Cisco released further information about each topic to several sublevels of hierarchy. In this table, those sublevels are indented to indicate the topic above them they are related to.

**Table I-8** ICND2 Exam Topics: LAN Switching Technologies

Chapters	LAN Switching Technologies
1	Identify enhanced switching technologies
1	RSTP
1	PVSTP
1	Etherchannels
1, 2	Configure and verify PVSTP operation
1, 2	describe root bridge election
2	spanning tree mode

**Table I-9** ICND2 Exam Topics, IP Routing Technologies

Chapters	IP Routing Technologies
20	Describe the boot process of Cisco IOS routers
20	POST
20	Router bootup process
12	Configure and verify operation status of a Serial interface.
20, 21	Manage Cisco IOS Files
20	Boot preferences
20	Cisco IOS image(s)
21	Licensing
21	Show license
21	Change license
8–11, 16–18	Differentiate methods of routing and routing protocols
8	Administrative distance
9	split horizon
8, 9, 17, 18	metric
8, 9, 17, 18	next hop

Chapters	IP Routing Technologies
8, 17	Configure and verify OSPF (single area)
8, 11, 17	neighbor adjacencies
8, 11, 17	OSPF states
8, 17	Discuss Multi area
8	Configure OSPF v2
17	Configure OSPF v3
8, 17	Router ID
8, 17	LSA types
9, 10, 18	Configure and verify EIGRP (single AS)
9, 10, 18	Feasible Distance / Feasible Successors /Administrative distance
9, 18	Feasibility condition
9, 18	Metric composition
9, 10, 18	Router ID
9, 10	Auto summary
9, 10, 18	Path selection
9, 10, 18	Load balancing
9, 10, 18	Equal
9, 10, 18	Unequal
9, 10, 18	Passive interface

**Table I-10** ICND2 Exam Topics, IP Services

Chapters	IP Services
6	Recognize High availability (FHRP)
6	VRRP
6	HSRP
6	GLBP
19	Configure and verify Syslog
19	Utilize Syslog Output
19	Describe SNMP v2 & v3

**Table I-11** ICND2 Exam Topics, Troubleshooting

Chapters	Troubleshooting
3–5, 16	Identify and correct common network problems
19	Utilize netflow data
2	Troubleshoot and Resolve Spanning Tree operation issues
2	root switch
2	priority

<b>Chapters</b>	<b>Troubleshooting</b>
2	mode is correct
2	port states
4, 5, 16	<b>Troubleshoot and Resolve routing issues</b>
4, 5, 16	routing is enabled
4, 5, 16	routing table is correct
4, 5, 16	correct path selection
11, 17	<b>Troubleshoot and Resolve OSPF problems</b>
11, 17	neighbor adjacencies
11, 17	Hello and Dead timers
11, 17	OSPF area
11, 17	Interface MTU
11, 17	Network types
11, 17	Neighbor states
11, 17	OSPF topology database
11, 18	<b>Troubleshoot and Resolve EIGRP problems</b>
11, 18	neighbor adjacencies
11, 18	AS number
11, 18	Load balancing
11, 18	Split horizon
3, 5	<b>Troubleshoot and Resolve interVLAN routing problems</b>
5	Connectivity
5	Encapsulation
5	Subnet
3, 5	Native VLAN
3, 5	Port mode trunk status
12, 14	<b>Troubleshoot and Resolve WAN implementation issues</b>
12	Serial interfaces
12	PPP
14	Frame relay
19	<b>Monitor NetFlow statistics</b>
2	<b>Troubleshoot etherchannel problems</b>

**Table I-12** ICND2 Exam Topics: WAN Technologies

Chapters	WAN Technologies
7, 13, 15	Identify different WAN Technologies
15	Metro Ethernet
15	VSAT
15	Cellular 3G / 4G
15	MPLS
12, 15	T1 / E1
15	ISDN
15	DSL
13	Frame relay
15	Cable
7	VPN
12	Configure and verify a basic WAN serial connection
12	Configure and verify a PPP connection between Cisco routers
14	Configure and verify Frame Relay on Cisco routers
15	Implement and troubleshoot PPPoE

### CCNA Exam Topics

The 200-120 CCNA exam actually covers everything from both the ICND1 and ICND2 exams, at least based on the published exam topics. As of publication, the CCNA exam topics include all topics in Tables I-1 through I-12. In short, CCNA = ICND1 + ICND2.

**NOTE** Because it is possible that the exam topics may change over time, it might be worth the time to double-check the exam topics as listed on the Cisco website (<http://www.cisco.com/go/ccent> and <http://www.cisco.com/go/ccna>). If Cisco does happen to add exam topics at a later date, note that Appendix B, “ICND2 Exam Updates,” describes how to go to <http://www.ciscopress.com> and download additional information about those newly added topics.

## About the Book

This book discusses the content and skills needed to pass the 200-101 ICND2 exam. That content also serves as basically the second half of the CCNA content, with this book’s companion title, the *Cisco CCENT/CCNA ICND1 100-101 Official Cert Guide, Academic Edition*, discussing the first half of the content.

Each of these books uses the same kinds of book features, so if you are reading both this book and the ICND1 book, you do not need to read the Introduction to the other book. Also, for those of you using both books to prepare for the 200-120 CCNA exam (rather than taking the two-exam option), the end of this Introduction lists a suggested reading plan.

## Book Features

The most important and somewhat obvious objective of this book is to help you pass the ICND2 exam or the CCNA exam. In fact, if the primary objective of this book were different, the book's title would be misleading! However, the methods used in this book to help you pass the exams are also designed to make you much more knowledgeable about how to do your job.

This book uses several tools to help you discover your weak topic areas, to help you improve your knowledge and skills with those topics, and to prove that you have retained your knowledge of those topics. So, this book does not try to help you pass the exams only by memorization, but by truly learning and understanding the topics. The CCNA certification is the foundation for many of the Cisco professional certifications, and it would be a disservice to you if this book did not help you truly learn the material. Therefore, this book helps you pass the CCNA exam by using the following methods:

- Helping you discover which exam topics you have not mastered
- Providing explanations and information to fill in your knowledge gaps
- Supplying exercises that enhance your ability to recall and deduce the answers to test questions
- Providing practice exercises on the topics and the testing process via test questions on the DVD

## Chapter Features

To help you customize your study time using these books, the core chapters have several features that help you make the best use of your time:

- **Introduction and Exam Topics:** Each chapter begins with an introduction to the chapter's main topics and a listing of the official exam topics that are covered in that chapter.
- **Foundation Topics:** These are the core sections of each chapter. They explain the protocols, concepts, and configuration for the topics in that chapter.
- **Review Activities:** At the end of the "Foundation Topics" section of each chapter, the "Review Activities" section lists a series of study activities that should be done at the end of the chapter. Each chapter includes the activities that make the most sense for studying the topics in that chapter. The activities include the following:
  - **Chapter Summaries:** This is a thorough summary of the main chapter topics for you to review. Make sure you understand all these points in detail, and refer to the chapter if not.
  - **Review Questions:** These questions offer a chance for you to assess how well you retained particular facts from the Foundation Topics.
  - **Review Key Topics:** The Key Topic icon appears next to the most important items in the "Foundation Topics" section of the chapter. The Key Topics Review activity lists the key topics from the chapter and their corresponding page numbers. Although the contents of the entire chapter could be on the exam, you should definitely know the information listed in each key topic.
  - **Complete Tables and Lists from Memory:** To help you exercise your memory and memorize some lists of facts, many of the more important lists and tables from the chapter are included in a document on the DVD. This document lists only partial information, allowing you to complete the table or list.
  - **Define Key Terms:** Although the exams may be unlikely to ask a question like "Define this term," the CCNA exams require that you learn and know a lot of networking terminology. This section lists the most important terms from the chapter, asking you to write a short definition and compare your answer to the Glossary at the end of this book.

- **Command Reference Tables:** Some book chapters cover a large amount of configuration and EXEC commands. These tables list the commands introduced in the chapter, along with an explanation. For exam preparation, use it for reference, but also read the table once when performing the Review Activities to make sure that you remember what all the commands do.

## Part Review

The Part Review tasks help you prepare to apply all the concepts in each respective part of the book. (Each book part contains a number of related chapters.) The Part Review includes sample test questions, which require you to apply the concepts from multiple chapters in that part, uncovering what you truly understood and what you did not quite yet understand. The Part Review also uses mind map exercises that help you mentally connect concepts, configuration, and verification, so that no matter what perspective a single exam question takes, you can analyze and answer the question.

The Part Reviews list tasks, along with checklists, so you can track your progress. The following list explains the most common tasks you will see in the Part Review; note that not all Part Reviews use every type of task.

- **Repeat Chapter Review:** Although you have already seen the chapter review questions from the chapters in a part, re-answering those questions can prove a useful way to review facts. The Part Review suggests that you repeat the chapter review questions, but using the Pearson IT Certification Practice Test (PCPT) exam software that comes with the book, for extra practice in answering multiple choice questions on a computer.
- **Answer Part Review Questions:** The PCPT exam software includes several exam databases. One exam database holds Part Review questions, written specifically for Part Review. These questions purposefully include multiple concepts in each question, sometimes from multiple chapters, to help build the skills needed for the more challenging analysis questions on the exams.
- **Review Key Topics:** Yes, again! They are indeed the most important topics in each chapter.
- **Create Configuration Mind Maps:** Mind maps are graphical organizing tools that many people find useful when learning and processing how concepts fit together. The process of creating mind maps helps you build mental connections between concepts and configuration commands, as well as develop your recall of the individual commands. For this task, you may create the mind map on paper or using any mind mapping or graphic organizer software. (For more information about mind maps, see the section “About Mind Maps and Graphic Visualization” in the Introduction of this book.)
- **Create Verification Mind Maps:** These mind mapping exercises focus on helping you connect router and switch **show** commands to either networking concepts or to configuration commands. Simply create the mind maps on paper or using any mind mapping or graphic organizer software.
- **Repeat Chapter Review Tasks (Optional):** Browse through all the Review Activities, and repeat any that you think might help you with review at this point.

## Final Prep Tasks

Chapter 22, at the end of this book, lists a series of preparation tasks that you can best use for your final preparation before taking the exam.

## Other Features

In addition to the features in each of the core chapters, this book, as a whole, has additional study resources, including the following:

- **DVD-based practice exam:** The companion DVD contains the powerful Pearson IT Certification Practice Test exam engine. You can take simulated ICND2 exams, as well as



simulated CCNA exams, with the DVD and activation code included in this book. (You can take simulated ICND1 and CCNA exams with the DVD in the *Cisco CCENT/CCNA ICND1 Official Cert Guide*, Academic Edition.)

- **CCNA ICND2 Simulator Lite:** This lite version of the best-selling CCNA Network Simulator from Pearson provides you with a means, right now, to experience the Cisco command-line interface (CLI). No need to go buy real gear or buy a full simulator to start learning the CLI. Just install it from the DVD in the back of this book.
- **eBook:** This Academic Edition comes complete with a free copy of the *Cisco CCNA Routing and Switching ICND2 200-101 Official Cert Guide Premium Edition eBook and Practice Test*. The Premium Edition eBook provides you with three different eBook files: PDF, EPUB, and Mobi (native Kindle format). In addition, the Premium Edition enables you to link all the questions from the practice test software to the PDF file of the book, so you can link directly to the book content from each question for further study. Instructions for accessing your Premium Edition can be found on the access code card in the DVD sleeve.
- **Mentoring videos:** The DVD included with this book includes four other instructional videos, about the following topics: OSPF, EIGRP, EIGRP Metrics, plus PPP and CHAP.
- **Companion website:** The website <http://www.ciscopress.com/title/1587143739> posts up-to-the-minute materials that further clarify complex exam topics. Check this site regularly for new and updated postings written by the author that provide further insight into the more troublesome topics on the exam.
- **PearsonITCertification.com:** The website <http://www.pearsonitcertification.com> is a great resource for all things IT-certification related. Check out the great CCNA articles, videos, blogs, and other certification preparation tools from the industry's best authors and trainers.
- **CCNA Simulator:** If you are looking for more hands-on practice, you might want to consider purchasing the CCNA Network Simulator. You can purchase a copy of this software from Pearson at <http://pearsonitcertification.com/networksimulator> or other retail outlets. To help you with your studies, I have created a mapping guide that maps each of the labs in the simulator to the specific sections in these CCNA cert guides. You can get this mapping guide for free on the Extras tab of the companion website.
- **Author's website and blogs:** The author maintains a website that hosts tools and links useful when studying for CCENT and CCNA. The site lists information to help you build your own lab, study pages that correspond to each chapter of this book and the ICND1 book, and links to the author's CCENT Skills blog and CCNA Skills blog. Start at <http://www.certskills.com>; check the tabs for study and blogs in particular.

## Book Organization, Chapters, and Appendices

This book contains 21 core chapters, Chapters 1 through 21, with Chapter 22 including some suggestions for how to approach the actual exams. Each core chapter covers a subset of the topics on the ICND2 exam. The core chapters are organized into sections. The core chapters cover the following topics:

### Part I: LAN Switching

- **Chapter 1, “Spanning Tree Protocol Concepts,”** discusses the concepts behind IEEE Spanning Tree Protocol (STP) and how it makes some switch interfaces block frames to prevent frames from looping continuously around a redundant switched LAN.
- **Chapter 2, “Spanning Tree Protocol Implementation,”** shows how to configure, verify, and troubleshoot STP implementation on Cisco switches.
- **Chapter 3, “Troubleshooting LAN Switching,”** reviews LAN switching topics from the ICND1 book, while moving toward a deeper understanding of those topics. In particular, this chapter examines the most common LAN switching issues and how to discover those issues when troubleshooting a network.

## Part II: IP Version 4 Routing

- **Chapter 4, “Troubleshooting IPv4 Routing Part I,”** reviews IPv4 routing, and then focuses on how to use two key troubleshooting tools to find routing problems: the **ping** and **tracert** commands.
- **Chapter 5, “Troubleshooting IPv4 Routing Part II,”** looks at the most common IPv4 problems and how to find the root causes of those problems when troubleshooting.
- **Chapter 6, “Creating Redundant First-Hop Routers,”** discusses the need for a First Hop Redundancy Protocol (FHRP), how the protocols make multiple routers act like a single default router, and the configuration and verification details of both Hot Standby Router Protocol (HSRP) and Gateway Load Balancing Protocol (GLBP).
- **Chapter 7, “Virtual Private Networks,”** discusses the need for VPN technology when sending private network data over public networks like the Internet. It also discusses basic tunneling configuration using generic routing encapsulation (GRE) tunnels on Cisco routers.

## Part III: IP Version 4 Routing Protocols

- **Chapter 8, “Implementing OSPF for IPv4,”** reviews the ICND1 book’s coverage of OSPF Version 2 (OSPFv2). It also takes the concepts deeper, with more discussion of the OSPF processes and database and with additional configuration options.
- **Chapter 9, “Understanding EIGRP Concepts,”** introduces the fundamental operation of the Enhanced Interior Gateway Routing Protocol (EIGRP) for IPv4 (EIGRPv4), focusing on EIGRP neighbor relationships, how it calculates metrics, and how it quickly converges to alternate feasible successor routes.
- **Chapter 10, “Implementing EIGRP for IPv4,”** takes the concepts discussed in the previous chapter and shows how to configure and verify those same features.
- **Chapter 11, “Troubleshooting IPv4 Routing Protocols,”** walks through the most common problems with IPv4 routing protocols, while alternating between OSPF examples and EIGRP examples.

## Part IV: Wide-Area Networks

- **Chapter 12, “Implementing Point-to-Point WANs,”** explains the core concepts of how to build a leased-line WAN and the basics of the two common data link protocols on these links: HDLC and PPP.
- **Chapter 13, “Understanding Frame Relay Concepts,”** explains how to build a Frame Relay WAN between routers, focusing on the protocols and concepts rather than the configuration.
- **Chapter 14, “Implementing Frame Relay,”** takes the concepts discussed in Chapter 13 and shows how to configure, verify, and troubleshoot those same features.
- **Chapter 15, “Identifying Other Types of WANs,”** gives a broad description of many other types of WAN technology, including Ethernet WANs, Multiprotocol Label Switching (MPLS), and digital subscriber line (DSL).

## Part V: IP Version 6

- **Chapter 16, “Troubleshooting IPv6 Routing,”** reviews IPv6 routing as discussed in the ICND1 book. It then shows some of the most common problems with IPv6 routing and discusses how to troubleshoot these problems to discover the root cause.
- **Chapter 17, “Implementing OSPF for IPv6,”** reviews the ICND1 book’s coverage of OSPF Version 3 (OSPFv3). It then compares some deeper OSPFv3 concepts and configuration with these same concepts for OSPFv2, as discussed earlier in Chapter 8.

- **Chapter 18, “Implementing EIGRP for IPv6,”** takes the EIGRP concepts discussed for IPv4 in Chapter 9 and shows how those same concepts apply to EIGRP for IPv6 (EIGRPv6). It then shows how to configure and verify EIGRPv6 as well.

#### Part VI: Network Management

- **Chapter 19, “Managing Network Devices,”** discusses the concepts and configuration of three common network management tools: Simple Network Management Protocol (SNMP), syslog, and NetFlow.
- **Chapter 20, “Managing IOS Files,”** explains some necessary details about router internals and IOS. In particular, it discusses the boot process on a router, how a router chooses which IOS image to use, and the different locations where a router can store its IOS images.
- **Chapter 21, “Managing IOS Licensing,”** discusses Cisco’s current methods of granting a particular router the right to use a particular IOS image and feature set through the use of IOS licenses.

#### Part VII: Final Review

- **Chapter 22, “Final Review,”** suggests a plan for final preparation once you have finished the core parts of the book, in particular explaining the many study options available in the book.

#### Part VIII: Appendixes (In Print)

- **Appendix A, “Numeric Reference Tables,”** lists several tables of numeric information, including a binary-to-decimal conversion table and a list of powers of 2.
- **Appendix B, “ICND2 Exam Updates,”** covers a variety of short topics that either clarify or expand on topics covered earlier in the book. This appendix is updated from time to time and posted at <http://www.ciscopress.com/title/1587143739>, with the most recent version available at the time of printing included here as Appendix B. (The first page of the appendix includes instructions on how to check to see if a later version of Appendix B is available online.)
- The **Glossary** contains definitions for all of the terms listed in the “Definitions of Key Terms” section at the conclusion of Chapters 1 through 21.

#### Appendixes (on the DVD)

The following appendixes are available in digital format on the DVD that accompanies this book:

- **Appendix C, “Answers to Review Questions,”** includes the explanations to all the questions from Chapters 1 through 21.
- **Appendix D, “Memory Tables,”** holds the key tables and lists from each chapter, with some of the content removed. You can print this appendix and, as a memory exercise, complete the tables and lists. The goal is to help you memorize facts that can be useful on the exams.
- **Appendix E, “Memory Tables Answer Key,”** contains the answer key for the exercises in Appendix D.
- **Appendix F, “Mind Map Solutions,”** shows an image of sample answers for all the part-ending mind map exercises.
- **Appendix G, “Study Planner,”** is a spreadsheet with major study milestones, where you can track your progress through your study.

## Reference Information

This short section contains a few topics available for reference elsewhere in the book. You may read these when you first use the book, but you may also skip these topics and refer back to them later. In particular, make sure to note the final page of this introduction, which lists several contact details, including how to get in touch with Cisco Press.

### Install the Pearson IT Certification Practice Test Engine and Questions

The DVD in the book includes the Pearson IT Certification Practice Test (PCPT) engine—software that displays and grades a set of exam-realistic multiple choice, drag-and-drop, fill-in-the-blank, and testlet questions. Using the PCPT engine, you can either study by going through the questions in study mode or take a simulated ICND2 or CCNA exam that mimics real exam conditions.

The installation process requires two major steps. The DVD in the back of this book has a recent copy of the PCPT engine. The practice exam—the database of ICND2 and CCNA exam questions—is not on the DVD. After you install the software, the PCPT software downloads the latest versions of both the software and the question databases for this book using your Internet connection.

**NOTE** The cardboard DVD case in the back of this book includes both the DVD and a piece of thick paper. The paper lists the digital product voucher code and instructions for accessing the eBook files and the practice exams associated with this book. *Do not lose the activation code.*

### Redeem Your Digital Product Voucher to Access the eBook and Practice Test Code

To use the practice test software, you must first redeem your digital product voucher found on the card in the DVD sleeve. To do so, follow these steps:

- Step 1.** If you have a Cisco Press account, go to [www.ciscopress.com/account](http://www.ciscopress.com/account) and log in. If you do not have a Cisco Press account, go to [www.ciscopress.com/join](http://www.ciscopress.com/join) and create an account.
- Step 2.** On your Account page, find the “Digital Product Voucher” box at the top of the right column.
- Step 3.** Type in your digital product voucher code found on the DVD card, and click Submit.

**NOTE** Codes are one-time use and may not be shared.

- Step 4.** The products and download link will now be listed under Digital Purchases on your Account page. Click the “refresh” links to generate your eBook files for download. Use the access code to unlock and download the Premium Edition practice exams in the Pearson IT Certification Practice Test software, as described in the following sections.

### Install the Software from the DVD

The software installation process is pretty routine as compared with other software installation processes. If you have already installed the Pearson IT Certification Practice Test software from

another Pearson product, you do not need to reinstall the software. Instead, just launch the software on your desktop and proceed to activate the practice exam from this book by using the activation code included in the DVD sleeve. The following steps outline the installation process:

- Step 1.** Insert the DVD into your PC.
- Step 2.** The software that automatically runs is the Cisco Press software to access and use all DVD-based features, including the exam engine and the DVD-only appendixes. From the main menu, click the **Install the Exam Engine** option.
- Step 3.** Respond to windows prompts as with any typical software installation process.

The installation process gives you the option to activate your exam with the activation code supplied on the paper in the DVD sleeve. This process requires that you establish a Pearson website login. You need this login to activate the exam, so please do register when prompted. If you already have a Pearson website login, you do not need to register again. Just use your existing login.

### Activate and Download the Practice Exam

When the exam engine is installed, you should then activate the exam associated with this book (if you did not do so during the installation process), as follows:

- Step 1.** Start the PCPT software from the Windows Start menu or from your desktop shortcut icon.
- Step 2.** To activate and download the exam associated with this book, from the My Products or Tools tab, click the **Activate** button.
- Step 3.** At the next screen, enter the activation key listed under the Premium Edition product on your account page on [www.ciscopress.com](http://www.ciscopress.com), and then click the **Activate** button.
- Step 4.** The activation process downloads the practice exam. Click **Next**, and then click **Finish**.

After the activation process is completed, the My Products tab should list your new exam. If you do not see the exam, make sure you have selected the My Products tab on the menu. At this point, the software and practice exam are ready to use. Simply select the exam and click the **Open Exam** button.

To update a particular product's exams that you have already activated and downloaded, simply select the **Tools** tab and click the **Update Products** button. Updating your exams ensures that you have the latest changes and updates to the exam data.

If you want to check for updates to the PCPT software, simply select the **Tools** tab and click the **Update Application** button. This will ensure that you are running the latest version of the software engine.

### Activating Other Products

The exam software installation process and the registration process have to happen only once. Then for each new product, you have to complete just a few steps. For instance, if you buy another new Cisco Press Official Cert Guide or Pearson IT Certification Cert Guide, extract the activation code from the DVD sleeve in the back of that book; you don't even need the DVD at this point. From there, all you have to do is start PCPT (if not still up and running), and perform steps 2 through 4 from the previous list.

## PCPT Exam Databases with This Book

The practice test questions come in different exams or exam databases. When you install the PCPT software and type in the activation code, the PCPT software downloads the latest version of all these exam databases. And with the ICND2 book alone, you get 10 different “exams,” or 10 different sets of questions, as listed in Figure I-2.

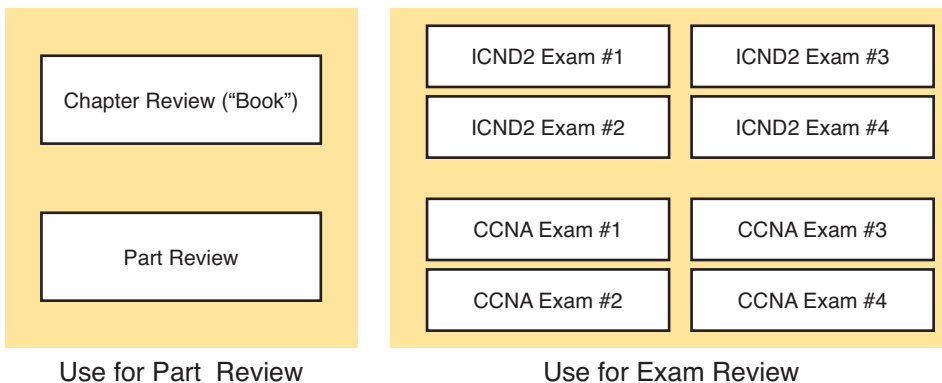

**Figure I-2** PCPT Exams/Exam Databases and When to Use Them

You can choose to use any of these exam databases at any time, both in study mode and practice exam mode. However, many people find it best to save some of the exams until exam review time, after you have finished reading the entire book. Figure I-2 begins to suggest a plan, spelled out here:

- During Part Review, use PCPT to review the Chapter Review questions (designated as “Book Questions” in the software) for that part, using study mode.
- During Part Review, use the questions built specifically for Part Review (the Part Review questions) for that part of the book, using study mode.
- Save the remaining exams to use with Chapter 22, “Final Review,” using practice exam mode, as discussed in that chapter.

The two modes inside PCPT give you better options for study versus practicing a timed exam event. In study mode, you can see the answers immediately, so you can study the topics more easily. Also, you can choose a subset of the questions in an exam database; for instance, you can view questions from only the chapters in one part of the book.

Practice exam mode creates an event somewhat like the actual exam. It gives you a preset number of questions, from all chapters, with a timed event. Practice exam mode also gives you a score for that timed event.

### How to View Only Chapter Review Questions by Part

Each Part Review asks you to repeat the Chapter Review quiz questions from the chapters in that part. You can simply scan the book pages to review these questions, but it is slightly better to review these questions from inside the PCPT software, just to get a little more practice in how to read questions from the testing software. But you can just read them in the book, as well.

To view these Chapter Review (book) questions inside the PCPT software, you need to select **Book Questions**, and the chapters in this part, using the PCPT menus. To do so, follow these steps:

- Step 1.** Start the PCPT software.
- Step 2.** From the main (home) menu, select the item for this product, with a name like Cisco CCNA Routing and Switching ICND2 200-101 Official Cert Guide, and click **Open Exam**.

- Step 3.** The top of the next window that appears should list some exams; check the **ICND2 Book Questions** box, and uncheck the other boxes. This selects the “book” questions (that is, the Chapter Review questions from the end of each chapter).
- Step 4.** On this same window, click at the bottom of the screen to deselect all objectives (chapters). Then select the box beside each chapter in the part of the book you are reviewing.
- Step 5.** Select any other options on the right side of the window.
- Step 6.** Click **Start** to start reviewing the questions.

### How to View Part Review Questions by Part Only

The exam databases you get with this book include a database of questions created solely for study during the Part Review process. Chapter Review questions focus more on facts, with basic application. The Part Review questions instead focus more on application and look more like real exam questions.

To view these questions, follow the same process as you did with Chapter Review/book questions, but select the Part Review database rather than the book database. Specifically, follow these steps:

- Step 1.** Start the PCPT software.
- Step 2.** From the main (home) menu, select the item for this product, with a name like Cisco CCNA Routing and Switching ICND2 200-101 Official Cert Guide, and click **Open Exam**.
- Step 3.** The top of the next window should list some exams; check the **Part Review Questions** box, and uncheck the other boxes. This selects the questions intended for part-ending review.
- Step 4.** On this same window, click at the bottom of the screen to deselect all objectives, and then select (check) the box beside the book part you want to review. This tells the PCPT software to give you Part Review questions from the selected part.
- Step 5.** Select any other options on the right side of the window.
- Step 6.** Click **Start** to start reviewing the questions.

### About Mind Maps

Mind maps are a type of visual organization tool that you can use for many purposes. For instance, you can use mind maps as an alternative way to take notes.

You can also use mind maps to improve how your brain organizes concepts. Mind maps stress the connections and relationships between ideas. When you spend time thinking about an area of study, and organize your ideas into a mind map, you strengthen existing mental connections, create new connections, all into your own frame of reference.

In short, mind maps help you internalize what you learn.

### Mind Map Mechanics

Each mind map begins with a blank piece of paper or blank window in an application. You then add a large central idea, with branches that move out in any direction. The branches contain smaller concepts, ideas, commands, pictures, whatever idea needs to be represented. Any concepts that can be grouped should be put near each other. As need be, you can create deeper and

deeper branches, although for this book's purposes, most mind maps will not go beyond a couple of levels.

**NOTE** Many books have been written about mind maps, but Tony Buzan often gets credit for formalizing and popularizing mind maps. You can learn more about mind maps at his website, <http://www.thinkbuzan.com>.

For example, Figure I-3 shows a sample mind map that begins to output some of the IPv6 content from Part VII of the ICND1 book. The central concept of the mind map is IPv6 addressing, and the Part Review activity asks you to think of all facts you learned about IPv6 addressing, and organize them with a mind map. The mind map allows for a more visual representation of the concepts as compared with just written notes.

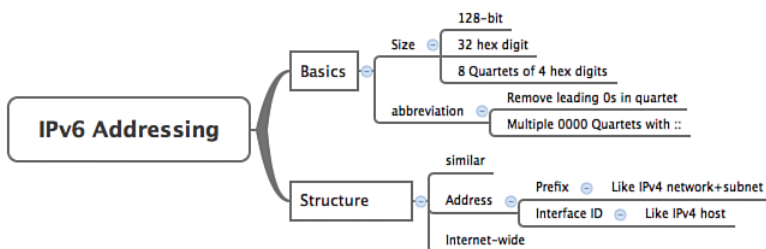

**Figure I-3** Sample Mind Map

### About Mind Maps Used During Part Review

This book suggests mind mapping exercises during Part Review. This short topic lists some details about the Part Review mind mapping exercises, listed in one place for reference.

Part Review uses two main types of mind mapping exercises:

*Configuration exercises* ask you to recall the related configuration commands and group them. For instance, in a configuration exercise, related commands that happen to be interface subcommands should be grouped, but as shown as being inside interface configuration mode.

*Verification exercises* ask you to think about the output of **show** commands and link the output to either the configuration commands that cause that output or the concepts that explain the meaning of some of that output.

Create these configuration mind maps on paper, using any mind mapping software, or even any drawing application. Many mind mapping apps exist as well. Regardless of how you draw them, follow these rules:

- If you have only a little time for this exercise, spend your time making your own mind map, instead of looking at suggested answers. The learning happens when thinking through the problem of making your own mind map.
- Set aside the book and all your notes, and do not look at them, when first creating these maps, and do as much as you can without looking at the book or your notes (or Google, or anything else).
- Try all the mind maps listed in a Part Review before looking at your notes.
- Finally, look at your notes to complete all the mind maps.
- Make a note of where you put your final results so that you can find them later during final exam review.



Finally, when learning to use these tools, take two other important suggestions as well. First, use as few words as possible for each node in your mind map. The point is for you to remember the idea and its connections, rather than explain the concept to someone else. Just write enough to remind yourself of the concept. Second, if the mind map process is just not working for you, discard the tool. Instead, take freeform notes on a blank piece of paper. Try to do the important part of the exercise—the thinking about what concepts go together—without letting the tool get in the way.

## About Building Hands-On Skills

You need skills in using Cisco routers and switches, specifically the Cisco command-line interface (CLI). The Cisco CLI is a text-based command-and-response user interface; you type a command, and the device (a router or switch) displays messages in response. To answer sim and simlet questions on the exams, you need to know a lot of commands, and you need to be able to navigate to the right place in the CLI to use those commands.

The best way to master these commands is to use them. Sometime during your initial reading of the first part of this book, you need to decide how you personally plan to build your CLI skills. This next topic discusses your options for getting the tools you need to build CLI skills.

## Overview of Lab Options

To effectively build your hands-on CLI skills, you either need real routers and switches, or at least something that acts like routers and switches. People who are new to Cisco technology often choose from a few options to get those skills.

First, you can use real Cisco routers and switches. You can buy them, new or used, or borrow them at work. You can rent them for a fee. You can even rent virtual Cisco router and switch lab pods from Cisco, in an offering called Cisco Learning Labs.

Simulators provide another option. Router and switch simulators are software products that mimic the behavior of the Cisco CLI, generally for the purpose of allowing people to learn. These products have an added advantage when learning: They usually have lab exercises as well.

Simulators come in many shapes and sizes, but the publisher sells simulators that are designed to help you with CCENT and CCNA study—plus they match this book! The Pearson CCENT Network Simulator and the Pearson CCNA Network Simulator both provide an excellent environment to practice the commands, as well as hundreds of focused labs to help you learn what you need to know for the exams. Both products have the same software code base; the CCNA product simply has labs for both ICND1 and ICND2, whereas the CCENT product has only the ICND1 labs.

This book does not tell you what option to use, but you should plan on getting some hands-on practice somehow. The important thing to know is that most people need to practice using the Cisco CLI to be ready to pass these exams.

I (Wendell) have collected some information and opinions about this decision on my website, at <http://certskills.com/labgear>. Those pages link to sites for Dynamips and for the Pearson simulator. Also, because the information never seemed to exist in any one place, this website includes many details about how to build a CCNA lab using used real Cisco routers and switches.

## A Quick Start with Pearson Network Simulator Lite

The decision of how to get hands-on skills can be a little scary at first. The good news: You have a free and simple first step. Install the Pearson NetSim Lite that comes with this book.

This lite version of the best-selling CCNA Network Simulator from Pearson provides you with a means, right now, to experience the Cisco CLI. No need to go buy real gear or buy a full simulator to start learning the CLI. Just install it from the DVD in the back of this book.

Of course, one reason that NetSim Lite comes on the DVD is that the publisher hopes you will buy the full product. However, even if you do not use the full product, you can still learn from the labs that come with NetSim Lite while deciding about what options to pursue.

**NOTE** The ICND1 and ICND2 books each contain a different version of the Sim Lite product, each with labs that match the book content. If you bought both books, make sure you install both Sim Lite products.

## For More Information

If you have any comments about the book, submit them via <http://www.ciscopress.com>. Just go to the website, select **Contact Us**, and type your message.

Cisco might make changes that affect the CCNA certification from time to time. You should always check <http://www.cisco.com/go/ccna> and <http://www.cisco.com/go/ccent> for the latest details.

The *Cisco CCNA Routing and Switching ICND2 200-101 Official Cert Guide, Academic Edition* helps you attain CCNA Routing and Switching certification. This is the CCNA ICND2 certification book from the only Cisco-authorized publisher. We at Cisco Press believe that this book certainly can help you achieve CCNA certification, but the real work is up to you! I trust that your time will be well spent.

*This page intentionally left blank*

*This page intentionally left blank*

# Getting Started

This Getting Started section provides some valuable advice about how to use the study features in this book. Taking a few minutes to read through this short section before going on to Chapter 1 helps you get the most out of the book, regardless of whether you are using it with the end goal of preparing for the CCNA Routing and Switching certification exams or just learning basic networking concepts.

## A Brief Perspective on Cisco Certification Exams

Cisco sets the bar pretty high for passing the ICND1, ICND2, and CCNA exams. Most anyone can study and pass these exams, but it takes more than just a quick read through the book and the cash to pay for the exam.

The challenge of these exams comes from many angles. Each of these exams covers a lot of concepts and many commands specific to Cisco devices. Beyond knowledge, these Cisco exams also require deep skills. You must be able to analyze and predict what really happens in a network. You must be able to configure Cisco devices to work correctly in those networks. And you must be ready to troubleshoot problems when the network does not work correctly.

The more challenging questions on these exams work a lot like a jigsaw puzzle, but with four out of every five puzzle pieces not even in the room. To solve the puzzle, you have to mentally re-create the missing pieces. To do that, you must know each networking concept and remember how the concepts work together. You also have to match the concepts with what happens on the devices with the configuration commands that tell the devices what to do. You also have to connect the concepts and the configuration with the meaning of the output of various troubleshooting commands to analyze how the network is working and why it is not working right now.

For instance, the ICND2 exam includes many troubleshooting topics. A simple question might ask you why a router that uses Open Shortest Path Version 2 (OSPFv2) might fail to form a neighbor relationship with another neighboring router. But a more exam-realistic question would make you think about why a router is missing a route, whether the root cause is related to OSPF, and, if OSPF, whether the root cause is related to OSPF neighbors.

The questions supply some of the information, like some pieces of the jigsaw puzzle, as represented with the white pieces in Figure 1. You have to apply your knowledge of IP routing and OSPF theory to the facts to come up with some of the other pieces of the puzzle. For a given question, some pieces of the puzzle may remain a mystery, but with enough of the puzzle filled in, you should be able to answer the question. And some pieces will just remain unknown for a given question.

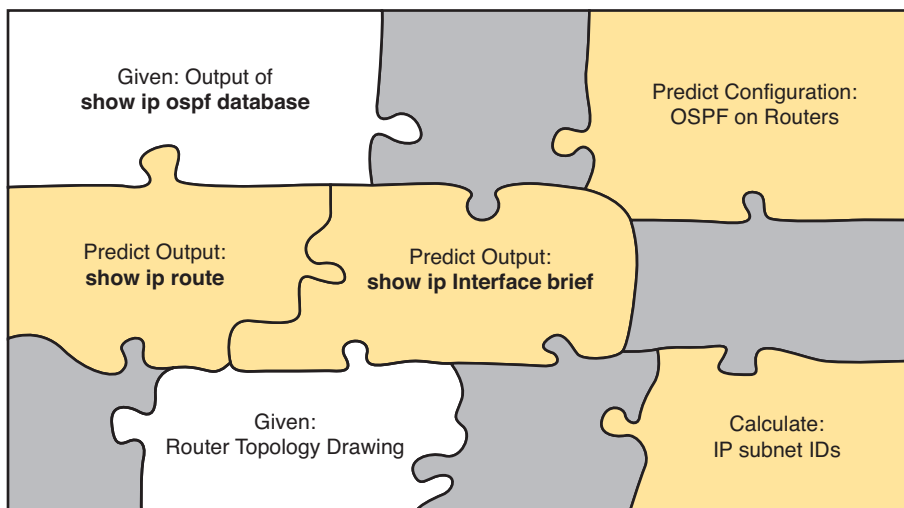

**Figure 1** *Filling in Puzzle Pieces with Your Analysis Skills*

These skills require that you prepare by doing more than just reading and memorizing what you read. Of course, you need to read many pages in this book to learn many individual facts and how these facts relate to each other. But a big part of this book lists exercises beyond reading, exercises that help you build the skills to solve these networking puzzles.

## Suggestions for How to Approach Your Study with This Book

Whether you are using this book with the goal of learning introductory networking concepts or to prepare for the CCNA Routing and Switching exams, you should consider a few things about how to use this book to achieve your goals. What do you need to do to be ready to pass the CCNA Routing and Switching exams or to be successful as a networking professional beyond reading and remembering all the facts? You must develop skills. You must mentally link each idea with other related ideas. Doing so requires additional work. To help you along the way, the next few pages give you five key perspectives about how to use this book to build those skills and make those connections, before you dive into this exciting but challenging world of learning networking on Cisco gear.

### Not One Book: 21 Short Read-and-Review Sessions

First, look at your study as a series of read-and-review tasks, each on a relatively small set of related topics.

Each of the core chapters of this book (1 through 21) have around 23 pages of content on average. If you glance around any of those chapters, you will find a heading called “Foundation Topics” on about the second page of each chapter. From there, to the “Review Activities” at the end of the chapter, the chapters average about 23 pages.

So, do not approach this book as one big book. Treat the task of your first read of a chapter as a separate task. Anyone can read 23 pages. Having a tough day? Each chapter has two or three major sections, so read just one of them. Or, do some related labs, or review something you have already read. The book organizes the content into topics of a more manageable size to give you something more digestible to manage your study time throughout the book.

## For Each Chapter, Do Not Neglect Practice

Next, plan to do the Review Activities at the end of each chapter.

Each chapter ends with practice and study tasks under a heading “Review Activities.” Doing these tasks, and doing them at the end of the chapter, really does help you get ready. Do not put off using these tasks until later! The chapter-ending Review Activities help you with the first phase of deepening your knowledge and skills of the key topics, remembering terms, and linking the concepts together in your brain so that you can remember how it all fits together.

The following list describes most of the activities you will find in the “Review Activities” sections:

- Chapter summary
- Review questions
- Review key topics
- Complete memory tables
- Define key terms
- Review command summary tables
- Review feature configuration checklists
- Do subnetting exercises

## Use Book Parts for Major Milestones

Third, view the book as having six major milestones, one for each major topic.

Beyond the more obvious organization into chapters, this book also organizes the chapters into six major topic areas called book parts. Completing each part means you have completed a major area of study. At the end of each part, take a little extra time. Do the Part Review tasks at the end of each part. Ask yourself where you are weak and where you are strong. And give yourself some reward for making it to a major milestone. Figure 2 lists the six parts in this book.

### Six Major Milestones: Book Parts

LAN Switching	Part Prep Tasks
IP Version 4 Routing	Part Prep Tasks
IP Version 4 Routing Protocols	Part Prep Tasks
Wide Area Networks	Part Prep Tasks
IP Version 6	Part Prep Tasks
Network Management	Part Prep Tasks

**Figure 2** *Parts as Major Milestones*

The tasks in the Part Reviews focus on helping you apply concepts (from that book part) to new scenarios for the exam. Some tasks use sample test questions so that you can think through and analyze a problem. This process helps you refine what you know and to realize what you did not quite yet understand. Some tasks use mind map exercises that help you mentally connect the theoretical concepts with the configuration and verification commands. These Part Review activities help build these skills.

Note that the Part Review directs you to use the Pearson IT Certification Practice Test (PCPT) software to access the practice questions. Each Part Review tells you to repeat the Chapter Review questions, but using the PCPT software. Each Part Review also directs you how to access

a specific set of questions reserved for reviewing concepts at part review. Note that the PCPT software and exam databases with this book give you the rights to additional questions, as well; Chapter 22, “Final Review,” gives some recommendations on how to best use those questions for your final exam preparation.

Also, consider setting a goal date for finishing each part of the book (and a reward, as well). Plan a break, some family time, some time out exercising, eating some good food, whatever helps you get refreshed and motivated for the next part.

### Use the Final Review Chapter to Refine Skills

Fourth, do the tasks outlined in the final preparation chapter (Chapter 22) at the end of this book.

The “Final Review” chapter has two major goals. First, it helps you further develop the analysis skills you need to answer the more complicated questions on the exam. Many questions require that you connect ideas about concepts, configuration, verification, and troubleshooting. More reading on your part does not develop all these skills; this chapter’s tasks give you activities to further develop these skills.

The tasks in the “Final Review” chapter also help you find your weak areas. This final element gives you repetition with high-challenge exam questions, uncovering any gaps in your knowledge. Many of the questions are purposefully designed to test your knowledge of the most common mistakes and misconceptions, helping you avoid some of the common pitfalls people experience with the actual exam.

### Set Goals and Track Your Progress

Finally, before you start reading the book and doing the rest of these study tasks, take the time to make a plan, set some goals, and be ready to track your progress.

While making lists of tasks may or may not appeal to you, depending on your personality, goal setting can help everyone studying for these exams. And to do the goal setting, you need to know what tasks you plan to do.

As for the list of tasks to do when studying, you do not have to use a detailed task list. (You could list every single task in every chapter-ending “Review Activities” section, every task in the Part Reviews, and every task in the “Final Preparation” chapter.) However, listing the major tasks can be enough.

You should track at least two tasks for each typical chapter: reading the “Foundation Topics” section and doing the “Review Activities” at the end of the chapter. And of course, do not forget to list tasks for Part Reviews and Final Review. Table 1 shows a sample for Part I of this book.

**Table 1** Sample Excerpt from a Planning Table

Element	Task	Goal Date	First Date Completed	Second Date Completed (Optional)
Chapter 1	Read Foundation Topics			
Chapter 1	Do Review Activities			
Chapter 2	Read Foundation Topics			
Chapter 2	Do Review Activities			
Chapter 3	Read Foundation Topics			
Chapter 3	Do Review Activities			
Part I Review	Do Part Review Activities			



**NOTE** Appendix G, “Study Planner,” on the DVD that comes with this book, contains a complete planning checklist like Table 1 for the tasks in this book. This spreadsheet allows you to update and save the file to note your goal dates and the tasks you have completed.

Use your goal dates as a way to manage your study, and not as a way to get discouraged if you miss a date. Pick reasonable dates that you can meet. When setting your goals, think about how fast you read and the length of each chapter’s “Foundation Topics” section, as listed in the table of contents. Then, when you finish a task sooner than planned, move up the next few goal dates.

If you miss a few dates, do *not* start skipping the tasks listed at the ends of the chapters! Instead, think about what is impacting your schedule—real life, commitment, and so on—and either adjust your goals or work a little harder on your study.

## Other Small Tasks Before Getting Started

You need to do a few overhead tasks to install software, find some PDFs, and so on. You can do these tasks now or do them in your spare moments when you need a study break during the first few chapters of the book. But do these early. That way, if you do stumble upon an installation problem, you have time to work through it before you need a particular tool.

Register (for free) at the Cisco Learning Network (CLN, <http://learningnetwork.cisco.com>) and join the CCENT and CCNA study groups. These mailing lists allow you to lurk and participate in discussions about topics related to CCENT (ICND1) and CCNA (ICND1 + ICND2). Register, join the groups, and set up an email filter to redirect the messages to a separate folder. Even if you do not spend time reading all the posts yet, later, when you have time to read, you can browse through the posts to find interesting topics (or just search the posts from the CLN website).

Find and print a copy of Appendix D, “Memory Tables.” Many of the “Chapter Review” sections use this tool, in which you take the incomplete tables from the appendix and complete the table to help you remember some key facts.

If you bought an ebook version of this book, find and download the media files (videos and Sim Lite software) per the instructions supplied on the last page of the ebook file under a “Where Are the Companion Files” heading.

Install the PCPT exam software and activate the exams. For more details on how to load the software, refer back to the Introduction, in the section “Install the Pearson IT Certification Practice Test Engine and Questions.”

Finally, install the Sim Lite software (unless you bought the full simulator product already). The Sim Lite that comes with this book contains a subset of the lab exercises in the full Pearson Network Simulator product.

## Getting Started: Now

Now dive in to your first of many short, manageable tasks: reading the relatively short introductory Chapter 1. Enjoy!

# Chapter 5

## Troubleshooting IPv4 Routing Part II

Chapter 4, “Troubleshooting IPv4 Routing Part I,” began the discussion of IPv4 troubleshooting, looking at the usual first steps when troubleshooting a problem. This chapter moves on to a later stage, when the problem has been isolated to a smaller part of the network, and to a smaller set of possible causes of the problem. The topics in this chapter get specific and look for those root causes: the causes of network problems that have specific solutions that, once a change is made, will solve the original problem.

This chapter breaks down the discussion based on the two major divisions in how packets are forwarded in an IPv4 internetwork. The first half of the chapter focuses on the root causes of problems between a host and its default router. The second half looks at the routers that forward the packet over the rest of a packet’s journey, from the router acting as default router all the way to the destination host.

Note that in addition to Chapters 4 and 5, other chapters in this book discuss troubleshooting topics that help when troubleshooting IPv4 internetworks. In particular, Chapter 11, “Troubleshooting IPv4 Routing Protocols,” discusses troubleshooting IPv4 routing protocols, namely Open Shortest Path First (OSPF) and Enhanced Interior Gateway Routing Protocol (EIGRP). Chapter 3, “Troubleshooting LAN Switching,” discussed how to troubleshoot LAN issues. Some topics inside the chapters in Part IV explain how to troubleshoot WAN links. Finally, Chapter 16, “Troubleshooting IPv6 Routing,” discusses how to apply these same IPv4 troubleshooting concepts to IPv6.

### This chapter covers the following exam topics:

#### Troubleshooting

- Identify and correct common network problems
- Troubleshoot and resolve interVLAN routing problems
  - Connectivity
  - Encapsulation
  - Subnet
  - Native VLAN
  - Port mode trunk status
- Troubleshoot and resolve routing issues
  - routing is enabled
  - routing table is correct
  - correct path selection

## Foundation Topics

### Problems Between the Host and the Default Router

Imagine that you work as a customer support rep (CSR) fielding calls from users about problems. A user left a message stating that he couldn't connect to a server. You could not reach him when you called back, so you did a series of pings from that host's default router, using some of the problem isolation strategies described in Chapter 4. And at the end of those pings, you think the problem exists somewhere between the user's device and the default router—for instance, between router R1 and host A, as shown in Figure 5-1.

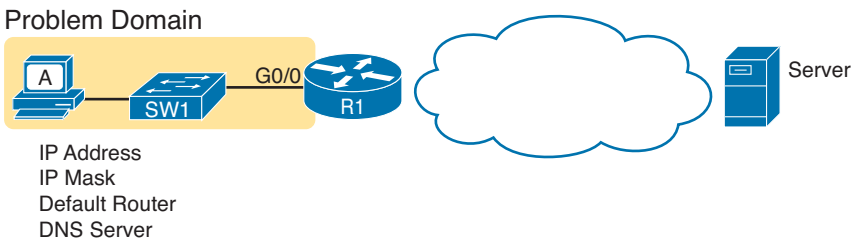

**Figure 5-1** Focus of the Discussions in This Section of the Chapter

This first major section of the chapter focuses on problems that can occur on hosts, their default routers, and between the two. To begin, this section looks at the host itself, and its four IPv4 settings, as listed in the figure. Following that, the discussion moves to the default router, with focus on the LAN interface, and the settings that must work for the router to serve as a host's default router.

#### Root Causes Based on a Host's IPv4 Settings

A typical IPv4 host gets its four key IPv4 settings in one of two ways: either through static configuration or by using DHCP. In both cases, the settings can actually be incorrect. Clearly, any static settings can be set to a wrong number just through human error when typing the values. More surprising is the fact that the DHCP can set the wrong values: The DHCP process can work, but with incorrect values configured at the DHCP server, the host can actually learn some incorrect IPv4 settings.

This section first reviews the settings on the host, and what they should match, followed by a discussion of typical issues.

#### Ensure IPv4 Settings Correctly Match

Once an engineer thinks that a problem exists somewhere between a host and its default router, the engineer should review of the host's IPv4 settings versus the intended settings. That process begins by guiding the user through the GUI of the host operating system or by using command-line commands native to host operating systems, such as **ipconfig** and **ifconfig**. This process should uncover obvious issues, like completely missing parameters, or if using DHCP, the complete failure of DHCP to learn any of the IPv4 settings.

If the host has all its settings, the next step is to check the values to match them with the rest of the internetwork. The Domain Name System (DNS) server IP address—usually a list of at least two addresses—should match the DNS server addresses actually used in the internetwork. The rest of the settings should be compared to the correct LAN interface on the router that is used as this host's default router. Figure 5-2 collects all the pieces that should match, with some explanation to follow.

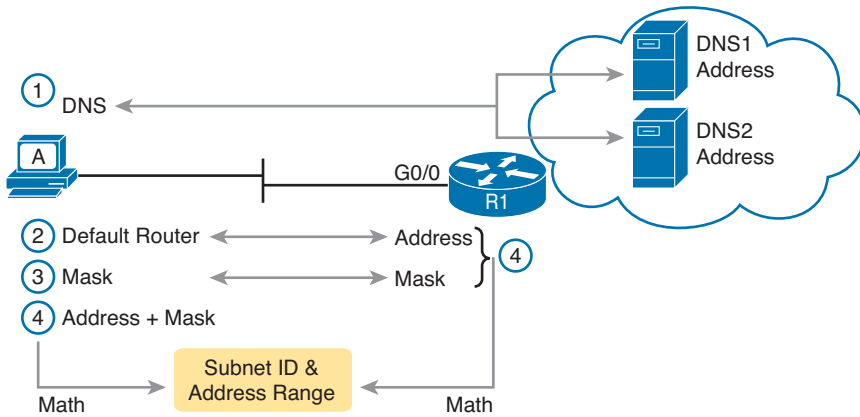

**Figure 5-2** Host IPv4 Settings Compared to What the Settings Should Match

As numbered in the figure, these steps should be followed to check the host's IPv4 settings:

- Step 1.** Check the host's list of DNS server addresses against the actual addresses used by those servers.
- Step 2.** Check the host's default router setting against the router's LAN interface configuration, for the `ip address` command.
- Step 3.** Check the subnet mask used by the router and the host; if they use a different mask, the subnets will not exactly match, which will cause problems for some host addresses.
- Step 4.** The host and router should attach to the exact same subnet—same subnet ID and same range of IP addresses. So, use both the router's and host's IP address and mask, calculate the subnet ID and range of addresses, and confirm they are in the same subnet as the subnet implied by the address/mask of the router's `ip address` command.

If an IPv4 host configuration setting is missing, or simply wrong, checking these settings can quickly uncover the root cause. For instance, if you can log in to the router and do a `show interfaces G0/0` command, and then ask the user to issue an `ipconfig /all` (or similar) command and read the output to you, you can compare all the settings in Figure 5-2.

However, although checking the host settings is indeed very useful, some problems related to hosts are not so easy to spot. The next few topics walk through some example problems to show some symptoms that occur when some of these less obvious problems occur.

### Mismatched Masks Impact Route to Reach Subnet

A host and its default router should agree about the range of addresses in the subnet. Sometimes, people are tempted to skip over this check, ignoring the mask either on the host or the router and assuming that the mask used on one device must be the same mask as on the other device. However, if the host and router have different subnet mask values, and therefore each calculates a different range of addresses in the subnet, problems happen.

To see one such example, consider the network in Figure 5-3. Host A has IP address/mask 10.1.1.9/24, with default router 10.1.1.150. Some quick math puts 10.1.1.150—the default router address—inside host A's subnet, right? Indeed it does, and it should. Host A's math for this subnet reveals subnet ID 10.1.1.0, with a range of addresses from 10.1.1.1 through 10.1.1.254, and subnet broadcast address 10.1.1.255.

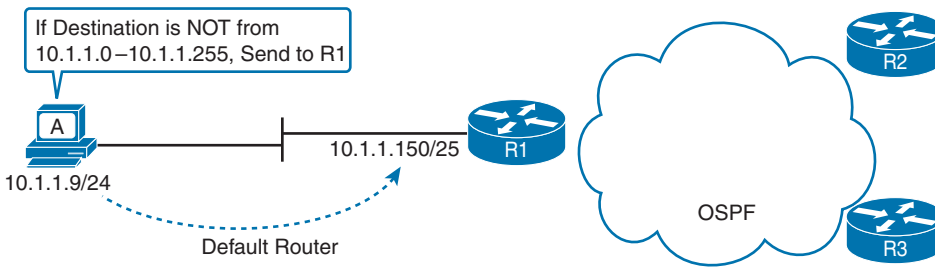

**Figure 5-3** Mismatched Subnet Calculations Appear Workable from Host Toward Network

In this case, the host routing of packets, to destinations outside the subnet, works well. However, the reverse direction, from the rest of the network back toward the host, does not. A quick check of router R1's configuration reveals the IP address/mask as shown in Figure 5-3, which results in the connected route for subnet 10.1.1.128/25, as shown in Example 5-1.

**Example 5-1** R1's IP Address, Mask, Plus the Connected Subnet That Omits Host A's Address

5

```
R1# show running-config interface g0/0
Building configuration...

Current configuration : 185 bytes
!
interface GigabitEthernet0/0
 description LAN at Site 1
 mac-address 0200.0101.0101
 ip address 10.1.1.150 255.255.255.128
 ip helper-address 10.1.2.130
 duplex auto
 speed auto
end

R1# show ip route connected
! Legend omitted for brevity

      10.0.0.0/8 is variably subnetted, 9 subnets, 4 masks
C       10.1.1.128/25 is directly connected, GigabitEthernet0/0
L       10.1.1.150/32 is directly connected, GigabitEthernet0/0
! Other routes omitted for brevity
```

Because of this particular mismatch, R1's view of the subnet puts host A (10.1.1.9) outside R1's view of the subnet (10.1.1.128/25, range 10.1.1.129 to 10.1.1.254). R1 adds a connected route for subnet 10.1.1.128/25 into R1's routing table, and even advertises this route (with OSPF in this case) to the other routers in the network, as seen in Figure 5-4. All the routers know how to route packets to subnet 10.1.1.128/25, but unfortunately, that route does not include host A's 10.1.1.9 IP address.

Hosts should use the same subnet mask as the default router, and the two devices should agree as to what subnet exists on their common LAN. Otherwise, problems may exist immediately, as in this example, or they might not exist until other hosts are added later.

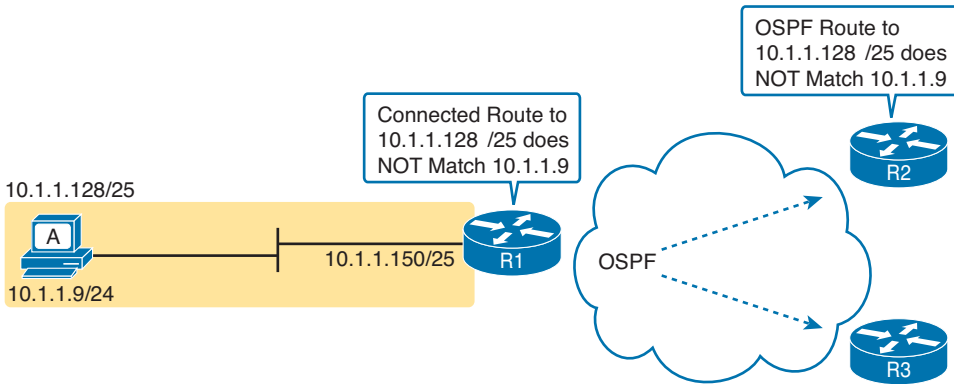

**Figure 5-4** Routers Have No Route That Matches Host A's 10.1.1.9 Address

### Typical Root Causes of DNS Problems

When a host lists the wrong IP addresses for the DNS servers, the symptoms are somewhat obvious: Any user actions that require name resolution fail. Assuming that the only problem is the incorrect DNS setting, any network testing with commands like **ping** and **tracert** fails when using names, but it works when using IP addresses instead of names.

When a ping of another host's hostname fails, but a ping of that same host's IP address works, some problem exists with DNS. For example, imagine a user calls the help desk complaining that he cannot connect to Server1. The CSR issues a **ping server1** command from the CSR's own PC, which both works and identifies the IP address of Server1 as 1.1.1.1. Then the CSR asks the user to try two commands from the user's PC: both a **ping Server1** command (which fails), and a **ping 1.1.1.1** command (which works). Clearly, the DNS name resolution process on the user's PC is having some sort of problem.

This book does not go into much detail about how DNS truly works behind the scenes, but the following two root causes of DNS problems do fit within the scope of the CCENT and CCNA:



- An incorrect DNS server setting
- An IP connectivity problem between the user's host and the DNS server

Although the first problem may be more obvious, note that it can happen both with static settings on the host and with DHCP. If a host lists the wrong DNS server IP address, and the setting is static, just change the setting. If the wrong DNS server address is learned with DHCP, you need to examine the DHCP server configuration. (If using the IOS DHCP server feature, you make this setting with the **dns-server server-address** command in DHCP pool mode.)

The second bullet point brings up an important issue for troubleshooting any real-world networking problem. Most every real user application uses names, not addresses, and most hosts use DNS to resolve names. So, every connection to a new application involves two sets of packets: packets that flow between the host and the DNS server, and packets that flow between the host and the real server, as shown in Figure 5-5.

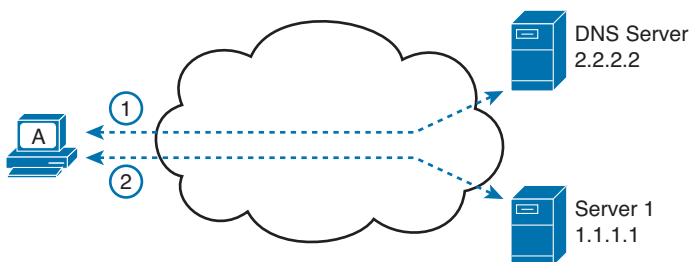

**Figure 5-5** DNS Name Resolution Packets Flow First; Then Packets to the Real Server

Finally, before leaving the topic of name resolution, note that the router can be configured with the IP addresses of the DNS servers, so that router commands will attempt to resolve names. For instance, a user of the router command-line interface (CLI) could issue a command `ping server1` and rely on a DNS request to resolve `server1` into its matching IP address. To configure a router to use a DNS for name resolution, the router needs the `ip name-server dns1-address dns2-address...` global command. It also needs the `ip domain-lookup` global command, which is enabled by default.

For troubleshooting, it can be helpful to set a router or switch DNS settings to match that of the local hosts. However, note that these settings have no impact on the user DNS requests.

**NOTE** On a practical note, IOS defaults with the `ip domain-lookup` command, but with no DNS IP address known. Most network engineers either add the configuration to point to the DNS servers or disable DNS using the `no ip domain-lookup` command.

### Wrong Default Router IP Address Setting

Clearly, having a host that lists the wrong IP address as its default router causes problems. Hosts rely on the default router when sending packets to other subnets, and if a host lists the wrong default router setting, the host may not be able to send packets to a different subnet.

Figure 5-6 shows just such an example. In this case, hosts A and B both misconfigure 10.1.3.4 as the default router due to the same piece of bad documentation. Router R3 uses IP address 10.1.3.3. (For the sake of discussion, assume that no other host or router in this subnet currently uses address 10.1.3.4.)

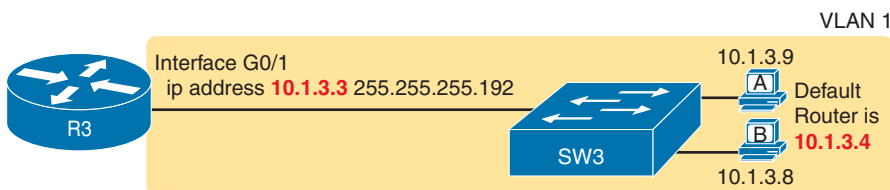

**Figure 5-6** *Incorrect Default Router Setting on Hosts A and B*

In this case, several functions do work. For instance, hosts A and B can send packets to other hosts on the same LAN. The CSR at the router CLI can issue a `ping 10.1.3.9` and `ping 10.1.3.8` command, and both work. As a result of those two working pings, R3 would list the MAC address of the two PCs in the output of the `show arp` command. Similarly, the hosts would list R3's 10.1.3.3 IP address (and matching MAC address) in their ARP caches (usually displayed with the `arp -a` command). The one big problem in this case happens when the hosts try to send packets off-subnet. In that case, try to send the packets to IP address 10.1.3.4 next, which fails.

### Root Causes Based on the Default Router's Configuration

While hosts must have correct IPv4 settings to work properly, having correct settings does not guarantee that a LAN-based host can successfully send a packet to the default router. The LAN between the host and the router must work. In addition, the router itself must be working correctly, based on the design of the internetwork.

This next topic looks at problems between hosts and their default router in which the root cause exists on the router. In particular, this topic looks at three main topics. The first topic looks at the trunking configuration required on a router to support multiple VLANs (known as router on a

stick, or ROAS). Following that, the text examines typical DHCP issues. The final root cause discussed here is the status of the router interface and what causes that interface to fail.

### Mismatched VLAN Trunking Configuration with Router on a Stick

Examples that teach configuration details often focus on one topic at a time. For instance, IPv4 configuration examples may show a host and its default router setting with the IP address configured on the router's LAN interface, as shown earlier in Example 5-1. However, the details of the LAN to which the host and router attach may be completely omitted, to focus on the IPv4 details.

Troubleshooting, both in real life and on the exams, requires that you put all the pieces together. This next example shows a great case of how the troubleshooting process suffers if you forget to think about both the router and switch part of the problem. This example shows a valid router configuration that, unfortunately, does not match the configuration on the neighboring LAN switch like it should.

The next example focuses on how to connect routers to the subnets on multiple VLANs in the same campus LAN. Today, most sites in an enterprise LAN use at least two VLANs. To make routing work today, one of two options is typically used:

- **Router on a Stick (ROAS):** A router connects to the LAN, with one physical interface configured for VLAN trunking. The router has an IP address in each subnet, with one subnet per VLAN. The router configuration adds each matched subnet and associated VLAN to a subinterface.
- **Layer 3 switch:** Also called a multilayer switch, a Layer 3 switch performs the same job as a router using ROAS, but the switch has routing functions built in. The switch configuration adds each matched subnet and associated VLAN to a VLAN interface.

This example happens to use ROAS, but many of the same kinds of mistakes shown here can be made with Layer 3 switch configurations as well.

First, the following list outlines the rules for configuring ROAS, using 802.1Q, on both the router and the neighboring switch:



**Step 1.** On the router, for each VLAN that is not the native VLAN, do the following:

- A.** Create a unique subinterface for each VLAN that needs to be routed (**interface type number.subint**).
- B.** Enable 802.1Q, and associate one specific VLAN with the subinterface in subinterface config mode (**encapsulation dot1q vlan-id**).
- C.** Configure IP settings (address and mask) in subinterface config mode (**ip address address mask**).

**Step 2.** On the router, for the native VLAN, if using it, use one of the two following options:

- A.** Configure just like for other VLANs, except add the **native** keyword to the encapsulation command (**encapsulation dot1q vlan-id native**).

Or

- B.** Configure the IP address on the physical LAN interface, without a subinterface and without the **encapsulation dot1q** command.



**Step 3.** On the switch, enable trunking (because the router will not negotiate to enable 802.1Q trunking):

- A. Enable trunking with the `switchport mode trunk` interface subcommand.
- B. Set the native VLAN to the same VLAN expected on the router, using the `switchport trunk native vlan vlan-id` interface subcommand.

Keeping that long list handy for reference, let's next walk through a brief example of the router configuration. First, imagine that previously a site used a single VLAN; so, the router configuration ignored VLAN trunking, with the IP address configured on the physical LAN interface on the router. All hosts sat in default VLAN 1. The router could ignore the VLAN details, not use trunking, and act as default router for all hosts in VLAN 1, as shown in Figure 5-7.

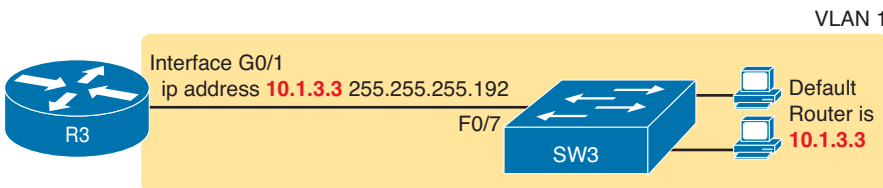
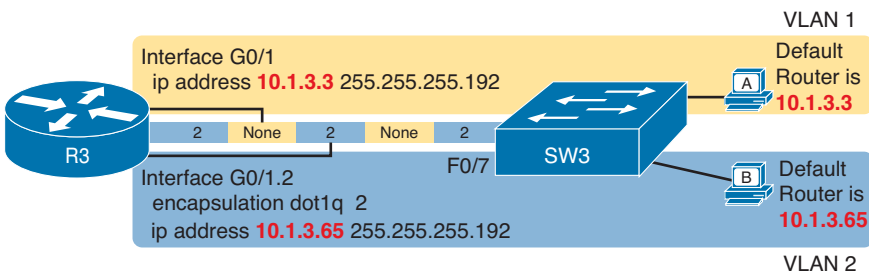

**Figure 5-7** Router IP Address Configuration, Without Trunking

Then, management planned an expansion in which a second VLAN will be used. This particular company has one network engineer in charge of routers and the other in charge of switches. When planning the changes with the switch engineer, the two engineers did not listen to each other very well, and then the router engineer went off to plan the changes to the router. The router engineer planned to make the following changes to use ROAS:

- Use ROAS on interface G0/1 to support both users in old subnet 10.1.3.0/26, in VLAN 1, and users in new subnet 10.1.3.64/26, in VLAN 2.
- To support VLAN 1 users, leave 10.1.3.3/26 configured as is on the physical interface. This takes advantage of the option to configure the native VLAN IP address on the physical interface because VLAN 1 is the default native VLAN.
- Add a ROAS subinterface to the router configuration to support VLAN 2, using address 10.1.3.65/26 as the router IP address/mask in that subnet.

Figure 5-8 shows the concepts and configuration.



**Figure 5-8** Router IP Address Configuration, with ROAS, and Native VLAN 1

This configuration could work perfectly well—as long as the switch has a matching correct VLAN trunking configuration. The router configuration implies a couple of things about VLAN trunking, as follows:

- With the IP address listed on physical interface G0/1, the configuration implies that the router intends to use the native VLAN, sending and receiving untagged frames.
- The router intends to use VLAN 2 as a normal VLAN, sending and receiving frames tagged as VLAN 2.

The switch (SW3) needs to configure VLAN trunking to match that logic. In this case, that means to enable trunking on that link, support VLANs 1 and 2, and make sure VLAN 1 is the native VLAN. Instead, in this case, the switch engineer actually added the trunk configuration to the wrong port, with the F0/7 port, connected to router R3, having these settings:

**switchport mode access**—The port does not trunk.

**switchport access vlan 7**—The port is assigned to VLAN 7.

The first command confirms, without a doubt, that the link from R3 to SW3 does not trunk. SW1 will not pass any VLAN 2 traffic over that link at all. A standard ping of host B's IP address from R3 fails; likewise, a **ping 10.1.3.65** command from host B fails.

The second command states that the access VLAN on F0/7 is VLAN 7, which means that SW1 will not forward VLAN 1's traffic over the link to R3, either. Again, pings between R3 and hosts in VLAN 1 will fail as well.

In summary, for ROAS configurations, take the time to verify the matching configuration on the neighboring switch. In particular

### Key Topic

- Make sure the switch enables trunking (**switchport mode trunk**).
- Make sure the switch sets the correct VLAN as that trunk's native VLAN (**switchport trunk native vlan *vlan-id***).
- Make sure the switch knows about all the VLANs the router has configured (**vlan *vlan-id***).

## DHCP Relay Issues

Hosts that use DHCP to lease an IP address (and learn other settings) rely on the network to pass the DHCP messages. In particular, if the internetwork uses a centralized DHCP server, with many remote LAN subnets using the DHCP server, the routers have to enable a feature called *DHCP Relay* to make DHCP work. Without DHCP Relay, DHCP requests from hosts never leave the local LAN subnet.

Figure 5-9 shows the big ideas behind how DHCP Relay works. In this example, a DHCP client (Host A) sits on the left, with the DHCP server (172.16.2.11) on the right. The client begins the DHCP lease process by sending a DHCP Discover message, one that would flow only across the local LAN without DHCP Relay configured on router R1. To be ready to forward the Discover message, R1 enables DHCP Relay with the **ip helper-address 172.16.2.11** command configured under its G0/0 interface.

The steps in the figure point out the need for DHCP Relay. At Step 1, host A sends a message, with destination IP and L2 broadcast address of 255.255.255.255 and ff:ff:ff:ff:ff:ff, respectively. Packets sent to this IP address, the “local subnet broadcast address,” should never be forwarded past the router. All devices on the subnet receive and process the frame. Additionally, because the **ip helper-address** command configured on R1, router R1 will continue to deencapsulate the frame and packet to identify that it is a DHCP request and take action. Step 2 shows the results of DHCP Relay, where R1 changes both the source and destination IP address, with R1 routing the packet to the address listed in the command: 172.16.2.11.

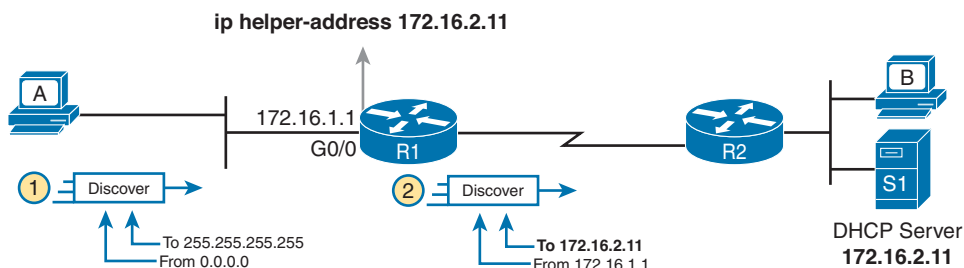

**Figure 5-9** IP Helper Address Effect

Now, back to troubleshooting. Messages sent by a DHCP client can reach the DHCP server if the following are true:

- The server is in the same subnet as the client, with connectivity working between the two.
- The server is on another subnet, with the router on the same subnet as the client correctly implementing DHCP Relay, and with IP connectivity from that router to the DHCP server.

Two common mistakes can be made with DHCP Relay, both of which are fairly obvious. If the router omits the `ip helper-address` command on a LAN interface (or subinterface when using ROAS, or VLAN interface with a multilayer switching [MLS] configuration), DHCP fails for those clients. If the configuration includes the `ip helper-address` command but lists the wrong DHCP server IP address, again DHCP fails completely.

The symptom in both cases is that the client learns nothing with DHCP.

For instance, Example 5-2 shows an updated configuration for ROAS on router R3, based on the same scenario as in Figure 5-8. The router configuration works fine for supporting IPv4 and making the router reachable. However, only one subinterface happens to list an `ip helper-address` command.

#### Example 5-2 Forgetting to Support DHCP Relay on a ROAS Subinterface

```
interface GigabitEthernet0/1
 ip address 10.1.3.3 255.255.255.192
 ip helper-address 10.1.2.130
!
interface GigabitEthernet0/1.2
 encapsulation dot1q 2
 ip address 10.1.3.65 255.255.255.192
```

In this case, hosts in VLAN 1 that want to use DHCP can, assuming the host at address 10.1.2.130 is indeed the DHCP server. However, hosts in VLAN 2 will fail to learn settings with DHCP because of the lack of an `ip helper-address` command.

### Router LAN Interface and LAN Issues

At some point, the problem isolation process may show that a host cannot ping its default router and vice versa. That is, neither device can send an IP packet to the other device on the same subnet. This basic test tells the engineer that the router, host, and LAN between them, for whatever reasons, cannot pass the packet encapsulated in an Ethernet frame between the two devices.

The root causes for this basic LAN connectivity issue fall into two categories:

- Problems that cause the router LAN interface to fail
- Problems with the LAN itself

A router's LAN interface must be in a working state before the router will attempt to send packets out that interface (or receive packets in that interface). Specifically, the router LAN interface must be in an up/up state; if in any other state, the router will not use the interface for packet forwarding. So, if a ping from the router to a LAN host fails (or vice versa), check the interface status, and if not up, find the root cause for the router interface to not be up.

Alternatively, the router interface can be in an up/up state, but problems can exist in the LAN itself. In this case, every topic related to Ethernet LANs may be a root cause. In particular, all the topics reviewed in Chapter 3, such as Ethernet cable pinouts, port security, and even Spanning Tree Protocol, may be root causes of LAN issues.

For instance, in Figure 5-10, router R3 connects to a LAN with four switches. R3's LAN interface (G0/1) can reach an up/up state if the link from R3 to SW1 works. However, many other problems could prevent R3 from successfully sending an IP packet, encapsulated in an Ethernet frame, to the hosts attached to switches SW3 and SW4.

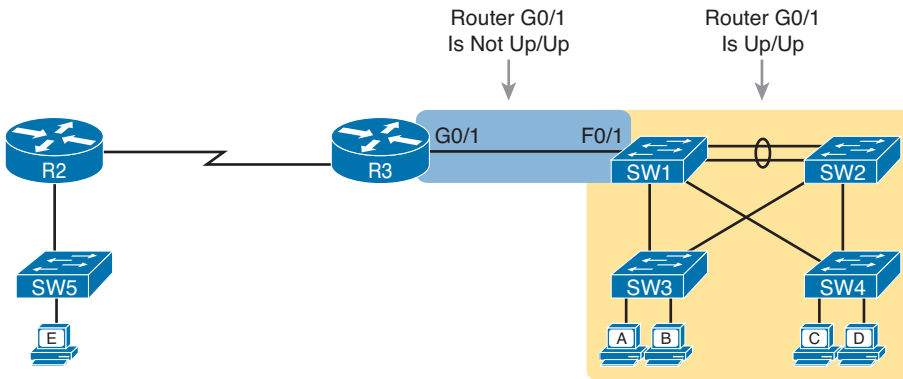

**Figure 5-10** *Where to Look for Problems Based on Router LAN Interface Status*

**NOTE** This book leaves the discussion of LAN issues, as shown on the right side of Figure 5-10, to Part I of this book.

Router LAN interfaces can fail to reach a working up/up state for several reasons. Table 5-1 lists the common reasons discussed within the scope of the CCNA exam.



**Table 5-1** Common Reasons Why Router LAN Interfaces Are Not Up/Up

Reason	Description	Router Interface State
Speed mismatch	The router and switch can both use the <b>speed</b> interface subcommand to set the speed, but to different speeds.	down/down
Shutdown	The router interface has been configured with the <b>shutdown</b> interface subcommand.	Admin down/down
Err-disabled switch	The neighboring switch port uses port security, which has put the port in an err-disabled state.	down/down
No cable/bad cable	The router has no cable installed, or the cable pinouts are incorrect.*	down/down

\* Cisco switches use a feature called auto-mdix, which automatically detects some incorrect cabling pinouts and internally changes the pin logic to allow the cable to be used. As a result, not all incorrect cable pinouts result in an interface failing.

Using the speed mismatch root cause as an example, you could configure Figure 5-10's R3's G0/1 with the **speed 1000** command and SW1's F0/1 interface with the **speed 100** command. The link simply cannot work at these different speeds, so the router and switch interfaces both fall to a down/down state. Example 5-3 shows the resulting state, this time with the **show interfaces description** command, which lists one line of output per interface.

**Example 5-3** show interfaces description *Command with Speed Mismatch*

```
R3# show interfaces description
```

Interface	Status	Protocol	Description
Gi0/0	up	up	
Gi0/1	down	down	link to campus LAN
Se0/0/0	admin down	down	
Se0/0/1	up	up	
Se0/1/0	up	up	
Se0/1/1	admin down	down	

## Problems with Routing Packets Between Routers

The first half of this chapter focused on the first hop that an IPv4 packet takes when passing over a network. This second major section now looks at issues related to how routers forward the packet from the default router to the final host.

In particular, this section begins by looking at the IP routing logic inside a single router. These topics review how to understand what a router currently does. Following that, the discussion expands to look at some common root causes of routing problems, causes that come from incorrect IP addressing, particularly when the addressing design uses variable-length subnet masks (VLSM).

The end of this section turns away from the core IP forwarding logic, looking at other issues that impact packet forwarding, including issues related to router interface status (which needs to be up/up) and how IPv4 access control lists (ACL) can filter IPv4 traffic.

### IP Forwarding by Matching the Most Specific Route

Any router's IP routing process requires that the router compare the destination IP address of each packet with the existing contents of that router's IP routing table. Often, only one route matches a particular destination address. However, in some cases, a particular destination address matches more than one of the router's routes.

The following CCENT and CCNA features can create overlapping subnets:

- Autosummary (as discussed in Chapter 10, "Implementing EIGRP for IPv4")
- Manual route summarization
- Static routes
- Incorrectly designed subnetting plans that cause subnets overlap their address ranges

In some cases, overlapping routes cause a problem; in other cases, the overlapping routes are just a normal result of using some feature. This section focuses on how a router chooses which of the overlapping routes to use, for now ignoring whether the overlapping routes are a problem. The section "Routing Problems Caused by Incorrect Addressing Plans," later in this chapter, discusses some of the problem cases.

Now on to how a router matches the routing table, even with overlapping routes in its routing table. If only one route matches a given packet, the router uses that one route. However, when more than one route matches a packet's destination address, the router uses the "best" route, defined as follows:

When a particular destination IP address matches more than one route in a router's IPv4 routing table, the router uses the most specific route—in other words, the route with the longest prefix length mask.

## Using `show ip route` and Subnet Math to Find the Best Route

We humans have a couple of ways to figure out what choice a router makes for choosing the best route. One way uses the `show ip route` command, plus some subnetting math, to decide the route the router will choose. To let you see how to use this option, Example 5-4 shows a series of overlapping routes.

### Example 5-4 `show ip route` Command with Overlapping Routes

```
R1# show ip route ospf
Codes: L - local, C - connected, S - static, R - RIP, M - mobile, B - BGP
       D - EIGRP, EX - EIGRP external, O - OSPF, IA - OSPF inter area
       N1 - OSPF NSSA external type 1, N2 - OSPF NSSA external type 2
       E1 - OSPF external type 1, E2 - OSPF external type 2
       i - IS-IS, su - IS-IS summary, L1 - IS-IS level-1, L2 - IS-IS level-2
       ia - IS-IS inter area, * - candidate default, U - per-user static route
       o - ODR, P - periodic downloaded static route, H - NHRP, l - LISP
       + - replicated route, % - next hop override

Gateway of last resort is 172.16.25.129 to network 0.0.0.0

    172.16.0.0/16 is variably subnetted, 9 subnets, 5 masks
O       172.16.1.1/32 [110/50] via 172.16.25.2, 00:00:04, Serial0/1/1
O       172.16.1.0/24 [110/100] via 172.16.25.129, 00:00:09, Serial0/1/0
O       172.16.0.0/22 [110/65] via 172.16.25.2, 00:00:04, Serial0/1/1
O       172.16.0.0/16 [110/65] via 172.16.25.129, 00:00:09, Serial0/1/0
O       0.0.0.0/0 [110/129] via 172.16.25.129, 00:00:09, Serial0/1/0
!
```

**NOTE** As an aside, the `show ip route ospf` command lists only OSPF-learned routes, but the statistics for numbers of subnets and masks (9 and 5 in the example, respectively) are for all routes, not just OSPF-learned routes.

To predict which of its routes a router will match, two pieces of information are required: the destination IP address of the packet and the contents of the router's routing table. The subnet ID and mask listed for a route defines the range of addresses matched by that route. With a little subnetting math, a network engineer can find the range of addresses matched by each route. For instance, Table 5-2 lists the five subnets listed in Example 5-4 and the address ranges implied by each.

**Table 5-2** Analysis of Address Ranges for the Subnets in Example 5-4

Subnet / Prefix	Address Range
172.16.1.1/32	172.16.1.1 (just this one address)
172.16.1.0/24	172.16.1.0–172.16.1.255
172.16.0.0/22	172.16.0.0–172.16.3.255
172.16.0.0/16	172.16.0.0–172.16.255.255
0.0.0.0/0	0.0.0.0–255.255.255.255 (all addresses)

**NOTE** The route listed as 0.0.0.0/0 is the default route.

As you can see from these ranges, several of the routes' address ranges overlap. When matching more than one route, the route with the longer prefix length is used. That is, a route with /16 is better than a route with /10; a route with a /25 prefix is better than a route with a /20 prefix; and so on.

For example, a packet sent to 172.16.1.1 actually matches all five routes listed in the routing table in Example 5-4. The various prefix lengths range from /0 to /32. The longest prefix (largest /P value, meaning the best and most specific route) is /32. So, a packet sent to 172.16.1.1 uses the route to 172.16.1.1/32, and not the other routes.

The following list gives some examples of destination IP addresses. For each address, the list describes the routes from Table 5-2 that the router would match, and which specific route the router would use.

- 172.16.1.1: Matches all five routes; the longest prefix is /32, the route to 172.16.1.1/32.
- 172.16.1.2: Matches last four routes; the longest prefix is /24, the route to 172.16.1.0/24.
- 172.16.2.3: Matches last three routes; the longest prefix is /22, the route to 172.16.0.0/22.
- 172.16.4.3: Matches the last two routes; the longest prefix is /16, the route to 172.16.0.0/16.

### Using `show ip route address` to Find the Best Route

A second way to identify the route a router will use, one that does not require any subnetting math, is the `show ip route address` command. The last parameter on this command is the IP address of an assumed IP packet. The router replies by listing the route it would use to route a packet sent to that address.

For example, Example 5-5 lists the output of the `show ip route 172.16.4.3` command on the same router used in Example 5-4. The first line of (highlighted) output lists the matched route: the route to 172.16.0.0/16. The rest of the output lists the details of that particular route, like the outgoing interface of S0/1/0 and the next-hop router of 172.16.25.129.

#### Example 5-5 `show ip route` Command with Overlapping Routes

```
R1# show ip route 172.16.4.3
Routing entry for 172.16.0.0/16
  Known via "ospf 1", distance 110, metric 65, type intra area
  Last update from 10.2.2.5 on Serial0/1/0, 14:22:06 ago
  Routing Descriptor Blocks:
  * 172.16.25.129, from 172.16.25.129, 14:22:05 ago, via Serial0/1/0
    Route metric is 65, traffic share count is 1
```

Certainly, if you have an option, just using a command to check what the router actually chooses is a much quicker option than doing the subnetting math.

### `show ip route` Reference

The `show ip route` command plays a huge role in troubleshooting IP routing and IP routing protocol problems. Many chapters in this book and in the ICND1 book mention various facts about this command. This section pulls the concepts together in one place for easier reference and study.

Figure 5-11 shows the output of a sample `show ip route` command. The figure numbers various parts of the command output for easier reference, with Table 5-3 describing the output noted by each number.

```

  ① 10.0.0.0/8 is variably subnetted, ② 13 subnets, ③ 5 masks
C   10.1.3.0/26 is directly connected, GigabitEthernet0/1
L   10.1.3.3/32 is directly connected, GigabitEthernet0/1
O   10.1.4.64/26 [110/65] via 10.2.2.10, 14:31:52, Serial0/1/0
O   ④ 10.2.2.0/30 [110/128] via ⑤ 10.2.2.5, ⑥ 14:31:52, ⑦ Serial0/0/1
    ⑧
    ⑨
    ⑩
    ⑪

```

**Figure 5-11** `show ip route` Command Output Reference

**Table 5-3** Descriptions of the `show ip route` Command Output

Item	Idea	Value in the Figure	Description
1	Classful network	10.0.0.0/8	The routing table is organized by classful network. This line is the heading line for classful network 10.0.0.0; it lists the default mask for class A networks (/8).
2	Number of subnets	13 subnets	Lists the number of routes for subnets of the classful network known to this router, from all sources, including local routes—the /32 routes that match each router interface IP address.
3	Number of masks	5 masks	The number of different masks used in all routes known to this router inside this classful network.
4	Legend code	C, L, O	A short code that identifies the source of the routing information. O is for OSPF, D for EIGRP, C for Connected, S for Static, and L for Local. (See Example 5-4 for a sample of the legend.)
5	Subnet ID	10.2.2.0	The subnet number of this particular route.
6	Prefix length	/30	The prefix mask used with this subnet.
7	Administrative distance	110	If a router learns routes for the listed subnet from more than one source of routing information, the router uses the source with the lowest AD.
8	Metric	128	The metric for this route.
9	Next-hop router	10.2.2.5	For packets matching this route, the IP address of the next router to which the packet should be forwarded.
10	Timer	14:31:52	For OSPF and EIGRP routes, this is the time since the route was first learned.
11	Outgoing interface	Serial0/0/1	For packets matching this route, the interface out which the packet should be forwarded.

## Routing Problems Caused by Incorrect Addressing Plans

The existence of overlapping routes in a router's routing table does not necessarily mean a problem exists. Both automatic and manual route summarization result in overlapping routes on some routers, with those overlaps not causing problems. However, some overlaps, particularly those related to addressing mistakes, can cause problems for user traffic. So, when troubleshooting, if



overlapping routes exist, the engineer should also look for the specific reasons for overlaps that actually cause a problem.

Simple mistakes in either the IP addressing plan or the implementation of that plan can cause overlaps that also cause problems. In these cases, one router claims to be connected to a subnet with one address range, while another router claims to be connected to another subnet with an overlapping range, breaking IP addressing rules. The symptoms are that the routers sometimes forward the packets to the right host, but sometimes not.

This problem can occur whether or not VLSM is used. However, the problem is much harder to find when VLSM is used. This section reviews VLSM, shows examples of the problem both with and without VLSM, and discusses the configuration and verification commands related to these problems.

### Recognizing When VLSM Is Used or Not

An internetwork is considered to be using VLSM when multiple subnet masks are used for different subnets of a *single classful network*. For example, if in one internetwork all subnets come from network 10.0.0.0, and masks /24, /26, and /30 are used, the internetwork uses VLSM.

Sometimes people fall into the trap of thinking that any internetwork that uses more than one mask must be using VLSM, but that is not always the case. For instance, if an internetwork uses subnets of network 10.0.0.0, all of which use mask 255.255.240.0, and subnets of network 172.16.0.0, all of which use a 255.255.255.0 mask, the design does not use VLSM. Two different masks are used, but only one mask is used in any single classful network. The design must use more than one mask for subnets of a single classful network to be using VLSM.

Only classless routing protocols can support VLSM. The current CCENT and CCNA Routing and Switching certifications cover only classless routing protocols (OSPF and EIGRP), so in all routing protocol discussions for this book, VLSM should be supported. However, for real life, note that RIPv2 (as a classless routing protocol) also supports VLSM, whereas classful routing protocols RIPv1 and Interior Gateway Routing Protocol (IGRP) cannot.

### Overlaps When Not Using VLSM

Even when you are not using VLSM, addressing mistakes that create overlapping subnets can occur. For instance, Figure 5-12 shows a sample network with router LAN IP address/mask information. An overlap exists, but it might not be obvious at first glance.

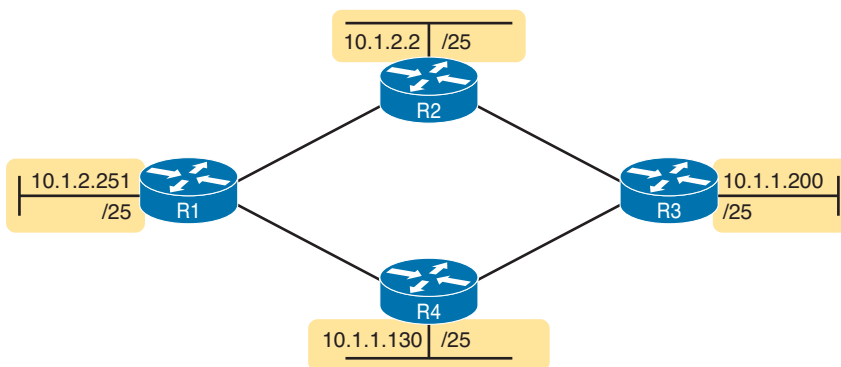

**Figure 5-12** IP Addresses on LAN Interfaces, with One Mask (/25) in Network 10.0.0.0

If an overlap exists when all subnets use the same mask, the overlapping subnets have the exact same subnet ID, and the exact same range of IP addresses in the subnet. To find the overlap, all you have to do is calculate the subnet ID of each subnet and compare the numbers. For instance,

Figure 5-13 shows an updated version of Figure 5-12, with subnet IDs shown and with identical subnet IDs for the LANs off R3 and R4.

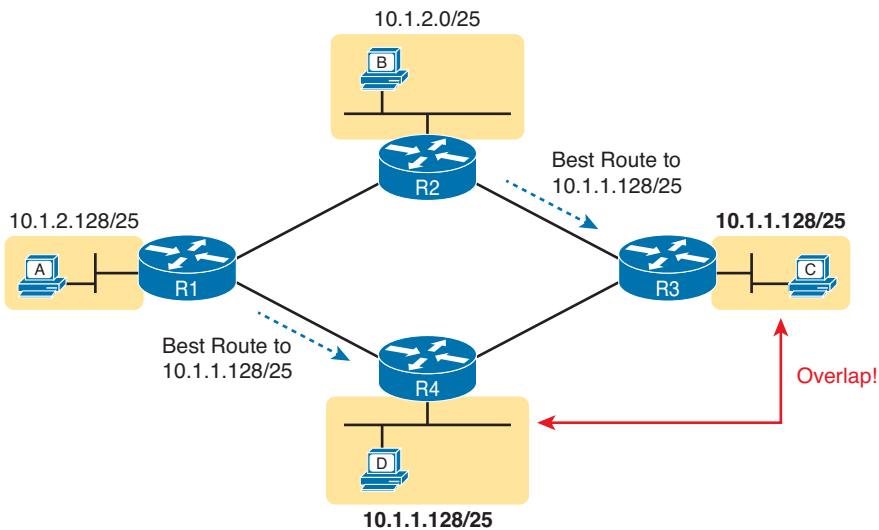

**Figure 5-13** Subnet IDs Calculated from Figure 5-12

Using the same subnet in two different places (as is done in Figure 5-13) breaks the rules of IPv4 addressing because the routers get confused about where to send packets. In this case, for packets sent to subnet 10.1.1.128/25, some routers send packets so they arrive at R3, whereas others think the best route points toward R4. Assuming all routers use a routing protocol, such as OSPF, both R3 and R4 advertise a route for 10.1.1.128/25.

In this case, R1 and R2 will likely send packets to two different instances of subnet 10.1.1.128/25. With these routes, hosts near R1 will be able to communicate with 10.1.1.128/25 hosts off R4's LAN, but not those off R3's LAN, and vice versa.

Finally, although the symptoms point to some kind of routing issues, the root cause is an invalid IP addressing plan. No IP addressing plan should use the same subnet on two different LANs, as was done in this case. The solution: Change R3 or R4 to use a different, nonoverlapping subnet on its LAN interface.

### Overlaps When Using VLSM

When using VLSM, the same kinds of addressing mistakes can lead to overlapping subnets; they just may be more difficult to notice.

First, overlaps between subnets that have different masks will cause only a partial overlap. That is, two overlapping subnets will have different sizes and possibly different subnet IDs. The overlap occurs between all the addresses of the smaller subnet, but with only part of the larger subnet. Second, the problems between hosts only occur for some destinations (specifically the subset of addresses in the overlapped ranges), making it even tougher to characterize the problem.

For instance, Figure 5-14 shows an example with a VLSM overlap. The figure shows only the IP address/mask pairs of router and host interfaces. First, look at the example and try to find the overlap by looking at the IP addresses.

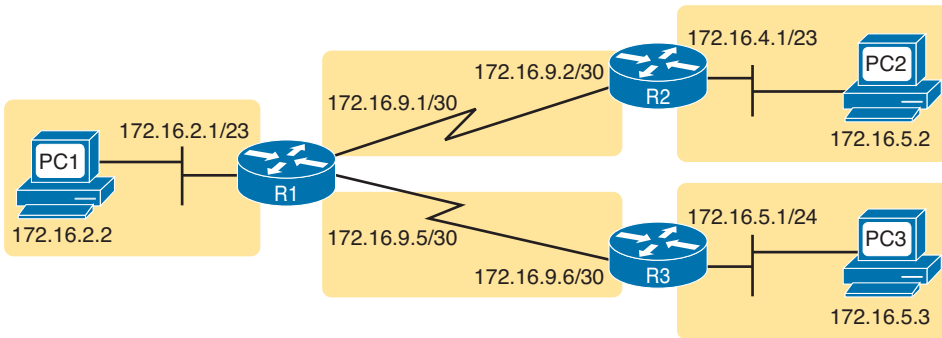
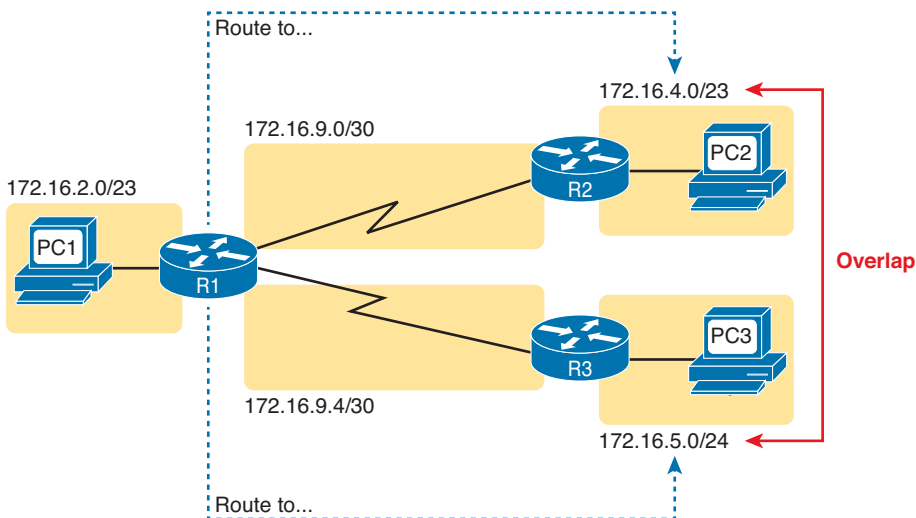

**Figure 5-14** VLSM IP Addressing Plan in Network 172.16.0.0

To find the overlap, the person troubleshooting the problem needs to analyze each subnet, finding not only the subnet ID but also the subnet broadcast address and the range of addresses in the subnet. If the analysis stops with just looking at the subnet ID, the overlap may not be noticed (as is the case in this example).

Figure 5-15 shows the beginning analysis of each subnet, with only the subnet ID listed. Note that the two overlapping subnets have different subnet IDs, but the lower-right subnet (172.16.5.0/24) completely overlaps with part of the upper-right subnet (172.16.4.0/23). (Subnet 172.16.4.0/23 has a subnet broadcast address of 172.16.5.255, and subnet 172.16.5.0/24 has a subnet broadcast address of 172.16.5.255.)

To be clear, the design with actual subnets whose address ranges overlap is incorrect and should be changed. However, once implemented, the symptoms show up as routing problems, like the similar case without VLSM. **ping** commands fail, and **traceroute** commands do complete for only certain hosts (but not all).



**Figure 5-15** A VLSM Overlap Example, But with Different Subnet IDs

### Configuring Overlapping VLSM Subnets

IP subnetting rules require that the address ranges in the subnets used in an internetwork should not overlap. IOS sometimes can recognize when a new **ip address** command creates an overlapping subnet, but sometimes not, as follows:

- **Preventing the overlap on a single router:** IOS detects the overlap when the **ip address** command implies an overlap with another **ip address** command *on the same router*.

- **Allowing the overlap on different routers:** IOS cannot detect an overlap when an `ip address` command overlaps with an `ip address` command on another router.

The router shown in Example 5-6 prevents the configuration of an overlapping VLSM subnet. The example shows router R3 configuring Fa0/0 with IP address 172.16.5.1/24 and attempting to configure Fa0/1 with 172.16.5.193/26. The ranges of addresses in each subnet are as follows:

**Subnet 172.16.5.0/24:** 172.16.5.1 – 172.16.5.254

**Subnet 172.16.5.192/26:** 172.16.5.193 – 172.16.5.254

#### Example 5-6 *Single Router Rejects Overlapped Subnets*

```
R3# configure terminal
R3(config)# interface Fa0/0
R3(config-if)# ip address 172.16.5.1 255.255.255.0
R3(config-if)# interface Fa0/1
R3(config-if)# ip address 172.16.5.193 255.255.255.192
% 172.16.5.192 overlaps with FastEthernet0/0
R3(config-if)#
```

IOS knows that it is illegal to overlap the ranges of addresses implied by a subnet. In this case, because both subnets would be connected subnets, this single router knows that these two subnets should not coexist because that would break subnetting rules, so IOS rejects the second command.

As an aside of how IOS handles these errors, IOS only performs the subnet overlap check for interfaces that are not in a shutdown state. When configuring an interface in shutdown state, IOS actually accepts the `ip address` command that would cause the overlap. Later, when the `no shutdown` command is issued, IOS checks for the subnet overlap and issues the same error message shown in Example 5-6. IOS leaves the interface in the shutdown state until the overlap condition has been resolved.

IOS cannot detect the configuration of overlapping subnets on different routers, as shown in Example 5-7. The example shows the configuration of the two overlapping subnets on R2 and R3 from Figure 5-15.

#### Example 5-7 *Two Routers Accept Overlapped Subnets*

```
! First, on router R2
R2# configure terminal
R2(config)# interface G0/0
R2(config-if)# ip address 172.16.4.1 255.255.254.0

! Next, on router R3
R3# configure terminal
R3(config)# interface G0/0
R3(config-if)# ip address 172.16.5.1 255.255.255.0
```

## Router WAN Interface Status

One of the steps in the IP routing troubleshooting process described earlier, in the “Router LAN Interface and LAN Issues” section, says to check the interface status, ensuring that the required interface is working. For a router interface to be working, the two interface status codes must both be listed as up, with engineers usually saying the interface is “up and up.”

So far, the ICND1 and ICND2 books have explored only basic information about how serial links work. For now, know that both routers must have working serial interfaces in an up/up state before they can send IPv4 packets to each other. The two routers should also have serial IP addresses in the same subnet.

Later, the chapters in Part IV further develop the details of WAN links, including what is required for routers to use these links to forward IP packets.

## Filtering Packets with Access Lists

Access control lists (ACL) cause some of the biggest challenges when troubleshooting problems in real networking jobs. End-user packets sent by user applications do not look exactly like packets sent by testing tools such as ping and traceroute. The ACLs sometimes filter the ping and traceroute traffic, making the network engineer think some other kind of problems exists when no problems exist at all. Or, the problem with the end-user traffic really is caused by the ACL, but the ping and traceroute traffic works fine, because the ACL filters the user traffic but not the ping and traceroute traffic.

This section summarizes some tips for attacking ACL-related problems in real life and on the exams:

- Step 1.** Determine on which interfaces ACLs are enabled, and in which direction (**show running-config**, **show ip interfaces**).
- Step 2.** Determine which ACL statements are matched by test packets (**show access-lists**, **show ip access-lists**).
- Step 3.** Analyze the ACLs to predict which packets should match the ACL, focusing on the following points:
  - A.** Remember that the ACL uses first-match logic.
  - B.** Consider using the (possibly) faster math described in the ICND1 book, Chapter 22, “Basic IP Access Control Lists,” to find the range of addresses matched by an ACL command: Add the address and wildcard mask to find the end of the numeric range.
  - C.** Note the direction of the packet in relation to the server (going to the server, coming from the server). Make sure that the packets have particular values as either the source IP address and port, or as the destination IP address and port, when processed by the ACL enabled for a particular direction (in or out).
  - D.** Remember that the **tcp** and **udp** keywords must be used if the command needs to check the port numbers.
  - E.** Note that ICMP packets do not use UDP or TCP. ICMP is considered to be another protocol matchable with the **icmp** keyword (instead of **tcp** or **udp**).
  - F.** Instead of using the implicit **deny** any at the end of each ACL, use an explicit configuration command to deny all traffic at the end of the ACL so that the **show** command counters increment when that action is taken.

If you suspect ACLs are causing a problem, the first problem-isolation step is to find the location and direction of the ACLs. The fastest way to do this is to look at the output of the **show running-config** command and to look for **ip access-group** commands under each interface. However, in some cases, enable mode access may not be allowed, and **show** commands are required. In that case, another way to find the interfaces and direction for any IP ACLs is the **show ip interfaces** command, as shown in Example 5-8.

**Example 5-8** *Sample show ip interface Command*

```

R1>show ip interface s0/0/1
Serial0/0/1 is up, line protocol is up
  Internet address is 10.1.2.1/24
  Broadcast address is 255.255.255.255
  Address determined by setup command
  MTU is 1500 bytes
  Helper address is not set
  Directed broadcast forwarding is disabled
  Multicast reserved groups joined: 224.0.0.9
  Outgoing access list is not set
  Inbound access list is 102
! roughly 26 more lines omitted for brevity

```

Note that the command output lists whether an ACL is enabled, in both directions, and which ACL it is. The example shows an abbreviated version of the **show ip interface S0/0/1** command, which lists messages for just this one interface. The **show ip interface** command would list the same messages for every interface in the router.

Step 2 then says that the contents of the ACL must be found. Again, the quickest way to look at the ACL is to use the **show running-config** command. If not available, the **show access-lists** and **show ip access-lists** commands list the same details shown in the configuration commands and a counter for the number of packets matching each line in the ACL. Example 5-9 shows an example.

**Example 5-9** *show ip access-lists Command Example*

```

R1# show ip access-lists
Extended IP access list 102
  10 permit ip 10.1.2.0 0.0.0.255 10.1.4.0 0.0.1.255 (15 matches)

```

After the locations, directions, and configuration details of the various ACLs have been discovered in Steps 1 and 2, the hard part begins—interpreting what the ACL really does.

Of particular interest is the last item in the troubleshooting tips list, item 3F. In the ACL shown in Example 5-9, some packets (15 so far) have matched the single configured **access-list** statement in ACL 102. However, some packets have probably been denied because of the implied deny all packets logic at the end of an ACL. If you configure the **access-list 102 deny ip any any** command at the end of the ACL, which explicitly matches all packets and discards them, the **show ip access-lists** command would then show the number of packets being denied at the end of the ACL.

Finally, as a reminder about interpreting ACL commands, when you know the command comes from a router, it is easy to decide the range of addresses matched by an address and wildcard mask. The low end of the range is the address (the first number), and the high end of the range is the sum of the address and wildcard mask. For instance, with ACL 102 in Example 5-9, which is obviously configured in some router, the ranges are as follows:

**Source 10.1.2.0, wildcard 0.0.0.255:** Matches from 10.1.2.0 through 10.1.2.255

**Destination 10.1.4.0, wildcard 0.0.1.255:** Matches from 10.1.4.0 through 10.1.5.255

## Review Activities

### Chapter Summary

- Many problems can occur on the host or the default router, or between the two.
- A typical IPv4 host gets its four key IPv4 settings either statically or dynamically.
- To begin troubleshooting the host, use the **ipconfig** or **ifconfig** command to ensure IPv4 settings correctly match. If you are using DHCP, the **ipconfig** or **ifconfig** command will enable you to see whether DHCP has failed to learn any of the IPv4 settings.
- The host and router should attach to the exact same subnet with the same subnet ID and same range of IP addresses.
- When a host lists the wrong IP addresses for the DNS servers, the user actions that require name resolution will fail.
- Any network testing with commands like **ping** and **tracert** fails when using names but works when using IP addresses when there is a problem with the DNS settings.
- Having a host that lists the wrong IP address as its default router will cause network problems.
- The default router's configuration can cause problems in a network that may stem from mismatched VLAN trunking configurations, DHCP relay issues, router LAN interface, and LAN issues.
- If a router omits the **ip helper-address** command on a LAN interface, DHCP fails for those clients.
- Another problem with network connectivity can exist with the routing or how a router forwards a packet.
- The **show ip route** command plays a huge role in troubleshooting IP routing and IP routing protocol problems.
- In some cases, overlapping routes cause a problem, while in other cases, the overlapping routes are just a normal result of using some feature.

### Review All the Key Topics

Review the most important topics from this chapter, noted with the Key Topic icon. Table 5-4 lists these key topics and where each is discussed.

**Table 5-4** Key Topics for Chapter 5

Key Topic Element	Description	Page Number
List	Two root causes of DNS problems.	136
List	The rules for configuring ROAS.	138
List	Items to verify for switch trunking configuration to match a router's ROAS configuration.	140
List	Conditions that must be true for DHCP messages to be able to flow from a client to a DHCP server.	141
Table 5-1	Common reasons why router LAN interfaces are not up/up.	142
Definition	When more than one route matches a packet's destination address, the router uses the "best" (most specific) route.	143
List	Types of overlapping IP address configuration issues that IOS can and cannot recognize.	149



## **Complete the Tables and Lists from Memory**

Print a copy of DVD Appendix D, “Memory Tables,” or at least the section for this chapter, and complete the tables and lists from memory. DVD Appendix E, “Memory Tables Answer Key,” includes completed tables and lists to check your work.

## **Definitions of Key Terms**

After your first reading of the chapter, try to define these key terms, but do not be concerned about getting them all correct at that time. Chapter 22 directs you in how to use these terms for late-stage preparation for the exam.



*This page intentionally left blank*

# Index

## Symbols

---

3DES (Triple DES), 180  
3G mobile phone access, 397-398  
4G mobile phone access, 397-398

## A

---

ABR (Area Border Router), 208  
access control lists (ACLs), 151-152  
access interface VLAN assignments, checking, 92  
access links  
    AR (access rate), 338  
    Frame Relay, 338  
        *Layer 1 issues*, 370  
        *Layer 2 issues*, 371  
access rate (AR), 338  
access VPNs (virtual private networks), 178  
ACLs (access control lists), 151-152  
activating IOS software, 529-530  
    Cisco License Manager (CLM), 530-531  
    manual activation, 531-536  
    right-to-use licenses, 536-538  
active/passive model, 160  
active/standby model, 160  
active virtual gateway (AVG), 163  
active VLANs, checking for, 92-93  
AD (administrative distance), 215-216  
Adaptive Security Appliances (ASA), 179  
address mapping (Frame Relay)  
    Inverse ARP, 360  
    static mapping, 360-361  
Address Resolution Protocol. *See* ARP  
addresses  
    Frame Relay, 357-359  
        *DLCI (data link connection identifiers)*, 342-344  
        *frame forwarding*, 344  
        *Layer 3 addressing*, 345-348  
    unicast IPv6 addresses, 411-413  
    adjacent OSPFv2 neighbors, 206  
    administrative distance (AD), 215-216  
    ADSL (asymmetric DSL), 395  
    AES (Advanced Encryption Standard), 180  
    anti-replay, 177  
    Area Border Router (ABR), 208  
    areas (OSPF)  
        design advantages, 209  
        design rules, 207  
        design terminology, 207-208  
        explained, 206-207  
        intra-area topology, 210-212  
        multi-area design, 212-213  
        multi-area OSPFv2, 217-223  
        reducing SPF calculation time with, 208  
        single-area OSPF, 206  
        single-area OSPFv2, 218-21  
    ARP (Address Resolution Protocol), 114  
        Inverse ARP, 360  
        replies (unicast), forwarding path of, 98-101  
        requests (broadcast), forwarding path of, 95-98  
        sample ARP process, 115  
    ASA (Adaptive Security Appliances), 179  
    ASN (autonomous system number), 239  
    asymmetric DSL (ADSL), 395  
    authentication  
        PAP/CHAP authentication, 328-329  
        PPP (Point-to-Point Protocol), 322-323  
    authNoPriv security level, 492  
    authPriv security level, 492  
    auto-cost reference-bandwidth command, 225, 228, 440, 458  
    autonomous system number (ASN), 239  
    autosummarization  
        discontiguous classful networks, 271-272  
        example of, 270-271  
    auto-summary command, 253, 271, 276  
    AVG (active virtual gateway), 163

## B

---

backbone area, 208  
backbone routers, 208  
backup DRs (BDRs), 205, 221-222  
balancing load

- EIGRPv4, 267-269
- EIGRPv6, 465
- HSRP (Hot Standby Router Protocol), 162
- OSPFv2 (Open Shortest Path First version 2), 225
- with PSVT+ (Per-VLAN Spanning Tree Plus), 38

bandwidth

- EIGRPv4 metric calculation, 243
- EIGRPv6 settings, 464-465
- reference bandwidth, 225

bandwidth command, 224, 228, 243, 264, 269, 276, 318, 334, 383, 440, 458, 462, 477  
Basic Rate Interface (BRI), 394  
BDR (backup DRs), 205, 221-222  
BID (bridge ID), 20, 39-40  
binary-to-hexadecimal conversion, 566  
blocking state (STP), 18-20  
boot sequence of Cisco IOS Software, 507-508

- configuration register, 509
- IOS image verification, 512-513
- OS selection process, 509-511
- recovery if IOS does not load, 511
- three-router operating systems, 508-509

boot system command, 509-510, 524  
boot system flash command, 511, 524  
boot system rom command, 524  
boot system tftp command, 511  
BPDU (bridge protocol data units), 20-21  
BPDU Guard, 30-31, 46-47  
BRI (Basic Rate Interface), 394  
bridge ID (BID), 20, 39-40  
bridge protocol data units (BPDU), 20-21  
broadcast storms, 16-17  
broadcasts

- ARP requests, forwarding path of, 95-98
- forwarding in VLAN 3, 97-98
- ignoring, 96-97

## C

---

Cable Internet, 396  
cable TV (CATV), 396  
cabling pinouts for LAN switches, 75  
calculating

- powers of 2, 567
- routes with EIGRP (Enhanced Interior Gateway Routing Protocol)
  - bandwidth issues*, 243
  - example*, 242-243
  - FD (feasible distance)*, 244-245
  - metric calculation*, 241
  - RD (reported distance)*, 244-245

CATV (cable TV), 396  
CCNA practice exams, 552-553  
CDP (Cisco Discovery Protocol), 72-73, 87-88  
cdp enable command, 73  
cdp run command, 73  
Challenge Handshake Authentication Protocol. *See* CHAP  
channel-group command, 48-50, 57-58, 62  
Channel service unit/data service unit. *See* CSU/DSU  
CHAP (Challenge Handshake Authentication Protocol), 398

- configuring, 324-325
- troubleshooting, 328-329

checking

- active interface VLAN assignments, 92
- for active VLANs, 92-93

choosing

- DPs (designated ports), 24-25
- RP (root ports), 23-24

CIR (committed information rate), 338  
circuits

- PVC (permanent virtual circuits), 338, 372-377
- SVC (switched virtual circuits), 338
- VC (virtual circuits)
  - explained*, 337-340
  - Layer 3 addressing*, 345-346

Cisco Catalyst switches, 80

- Cisco Certification Exam Tutorial, 546-547
- Cisco Learning Network, 558
- Cisco License Manager (CLM), 530-531
- Cisco Prime, 487
- Cisco Product License Registration Portal, 532
- classful routing protocols, 270
- clear ip ospf process command, 202, 229, 296
- CLI (command-line interface), 556-557
- clients, VPN (virtual private network) clients, 179
- CLM (Cisco License Manager), 530-531
- clock rate command, 316-318
- clock speed command, 334
- collector (NetFlow), 500
- committed information rate (CIR), 338
- community strings (SNMP), 490
- config-register command, 509, 524
- configuration files, 517-518
  - copying, 519-520
  - erasing, 519-520
  - running-config, 517
  - setup mode, 521
  - startup-config, 517
- configuration register, 509
- configuring
  - BPDU Guard, 46-47
  - CHAP (Challenge Handshake Authentication Protocol), 324-325
  - Cisco Catalyst switches, 80
  - EIGRPv4
    - basic configuration, 253-254*
    - compared to EIGRPv6, 466-467*
    - convergence, 265-266*
    - feasible successors, 263-265*
    - load balancing, 267-269*
    - maximum-paths, 267-269*
    - metric calculation, 269-270*
    - metric components, 266-267*
    - successors, 262-263*
    - topology table, viewing, 261-262*
    - variance, 268-269*
    - verifying core features of, 255-260*
    - wildcard masks, 255*
  - EIGRPv6
    - bandwidth and delay settings, 464-465*
    - basic configuration, 461*
    - compared to EIGRPv4, 466-467*
    - configuration commands, 462*
    - example, 462-464*
    - interfaces, 467-469*
    - IPv6 routes, 472-473*
    - load balancing, 465*
    - neighbors, 469-470*
    - overview, 461*
    - timers, 466*
    - topology database, 470-472*
  - EtherChannel, 47-48
    - Channel, 48-49*
    - channel-group command options, 57-58*
    - interface configuration settings, 58-59*
    - manual EtherChannel, 50*
  - Frame Relay
    - address mapping, 357-361*
    - encapsulation, 356*
    - fully meshed networks with one IP subnet, 354-355*
    - LMI (Local Management Interface), 356*
    - multipoint subinterfaces, 366-368*
    - OSPF (Open Shortest Path First), 368-369*
    - planning configurations, 353-354*
    - point-to-point subinterfaces, 361-364*
    - self-assessment, 381-382*
    - verification, 364-365*
  - GLBP (Gateway Load Balancing Protocol), 167-169
  - GRE (generic routing encapsulation) tunnels, 185-187
  - HDLC (High-level Data Link Control), 317-320
  - HSRP (Hot Standby Router Protocol), 164-167
  - IPv6 hosts
    - router address, 415-416*
    - SLAAC (stateless address autoconfiguration), 414-415*

- stateful DHCPv6*, 413-414
  - static routes*, 416-417
  - verifying connectivity*, 417-420
  - NetFlow, 497-498
  - OSPFv2 (Open Shortest Path First version 2)
    - basic configuration*, 216-217
    - load balancing*, 225
    - multi-area configuration*, 217-220
    - single-area configuration*, 218-219
    - verifying configuration*, 220-223
  - OSPFv3 (Open Shortest Path First version 3)
    - basic configuration*, 435
    - default routes*, 440-441
    - interface cost*, 439-440
    - load balancing*, 440
    - multi-area configuration*, 435-439
    - single-area configuration*, 436-438
  - overlapping subnets, 149-150
  - PortFast, 46-47
  - PPP (Point-to-Point Protocol), 323-324
  - PPPoE (PPP over Ethernet), 399-400
  - SNMP (Simple Network Management Protocol)
    - SNMP version 2c*, 490-491
    - SNMP version 3*, 491
  - STP (Spanning Tree Protocol)
    - BID (bridge ID)*, 39-40
    - BPDU Guard*, 46-47
    - defaults and configuration options*, 40
    - EtherChannel*, 47-50
    - per-VLAN configuration settings*, 38-39
    - per-VLAN costs*, 40
    - port costs*, 44
    - PortFast*, 46-47
    - STP mode*, 37-38
    - STP port costs*, 43-45
    - switch priority*, 44-46
    - system ID extension*, 39-40
    - verifying STP operation*, 40-43
  - Syslog (System Message Logging), 494-495
  - confreg command, 514
  - contiguous classful networks, 271
  - control plane, 66
  - control plane analysis, 67-68
  - convergence
    - EIGRP (Enhanced Interior Gateway Routing Protocol)
      - explained*, 244
      - feasible successors*, 265-266
      - query/reply process*, 246-247
      - successors*, 245-246
    - STP (Spanning Tree Protocol), 19
      - delays*, 28
      - troubleshooting*, 56
  - converting
    - binary to hexadecimal, 566
    - decimal to binary, 563-565
    - hexadecimal to binary, 566
  - copy command, 519, 525
  - copy running-config startup-config command, 509, 515, 519, 525
  - copy startup-config running-config command, 515-519, 525
  - copying
    - configuration files, 519-520
    - images into Flash memory, 505-507
  - CPE (customer premise equipment), 313
  - CSU/DSU, 315
  - customer premise equipment (CPE), 313
- ## D
- 
- data communications equipment (DCE), 338
  - Data Encryption Standard (DES), 180
  - data link connection identifiers (DLCI), 338
    - explained*, 342
    - frame forwarding*, 343-344
    - local DLCI*, 342-343
  - data link headers, building, 114-115
  - data plane, 66
  - data plane analysis, 66-67
  - data terminal equipment (DTE), 337-338, 345
  - datak9, 530
  - Dead Interval timer, 204

- debug eigrp fsm command, 277
- debug eigrp packets command, 302
- debug frame-relay lmi command, 365, 384
- debug ip ospf adj command, 294, 302
- debug ip ospf events command, 302
- debug ip ospf hello command, 297, 302
- debug ip ospf packet command, 302
- debug ipv6 ospf adj command, 445
- debug ppp authentication command, 328, 335
- debug ppp negotiation command, 335
- debug spanning-tree events command, 44, 63
- decimal-to-binary conversion, 563-565
- dedicated routers (DRs), verifying, 221-222
- default-information originate command, 441-442
- default routers, troubleshooting, 133
  - DHCP Relay, 140-141
  - DNS problems, 136-137
  - IP address settings, 137
  - LAN issues, 141-142
  - mismatched IPv4 settings, 133-134
  - mismatched masks, 134-135
  - mismatched VLAN trunking configuration, 138-140
- default routes (OSPFv3), 440-441
- delay, EIGRPv6 settings, 464-465
- delay command, 269, 276, 462, 477
- delivery headers, 184
- DES (Data Encryption Standard), 180
- description command, 334
- designated ports (DPs)
  - choosing, 24-25
  - determining, 54-55
  - explained, 19
  - strategies for DP exam questions, 55-56
- designated routers (DRs), 205-206
- determining
  - duplex issues, 77-78
  - root switches, 51-52
  - RPs (root ports), 52-54
  - switch interface speed, 76-78
- DHCP (Dynamic Host Configuration Protocol)
  - Relay, 140-141
  - stateful DHCP, 424-425
  - stateful DHCPv6, 413-414
- dial access, 393-394
- dialer pool command, 400
- Diffusing Update Algorithm (DUAL), 246
- digital subscriber line (DSL), 395-396
- dir command, 541
- discontiguous classful networks, 271-272
- distance vector (DV) routing protocols
  - explained, 233-234
  - full update messages, 234-235
  - route poisoning, 236-237
  - split horizon, 235-236
- DLCI (data link connection identifiers)
  - explained, 342
  - frame forwarding, 343-344
  - Frame Relay, 338
  - local DLCI, 342-343
- DNS (Domain Name Service)
  - name resolution, 123
  - troubleshooting
    - in IPv4*, 136-137
    - in IPv6*, 424
- dns-server command, 136
- Domain Name Service. *See* DNS
- DPs (designated ports)
  - choosing, 24-25
  - determining, 54-55
  - explained, 19
  - strategies for DP exam questions, 55-56
- DROthers, 206
- DRs (dedicated routers), 221-222
- DRs (designated routers), 205-206
- DSL (digital subscriber line), 395-396
- DSLAM (DSL access multiplexer), 395
- DTE (data communications equipment), 337-338, 345
- DUAL (Diffusing Update Algorithm), 246
- duplex half command, 77
- duplex mismatch, 77-78, 89-90

duplicate OSPF router IDs, finding, 295-296

DV (distance vector) routing protocols  
 explained, 233-234  
 full update messages, 234-235  
 route poisoning, 236-237  
 split horizon, 235-236

dynamic EtherChannels, configuring, 50

## E

---

Echo Requests (ICMP), 127

EIGRP router-id command, 258, 462-463, 477

EIGRPv4 (Enhanced Interior Gateway Routing Protocol version 4), 460  
 advantages of, 232  
 autosummarization  
   *discontiguous classful networks*, 271-272  
   *example of*, 270-271  
 compared to EIGRPv6, 466-467  
 compared to other routing protocols, 232-233, 238  
 configuring  
   *basic configuration*, 253-254  
   *feasible successors*, 265  
   *maximum-paths*, 267-269  
   *variance*, 268  
 convergence, 265-266  
   *explained*, 244  
   *query/reply process*, 246-247  
   *successors*, 245-246, 265  
 development of, 231  
 discontiguous classful networks, 271-272

DUAL (Diffusing Update Algorithm), 246  
 explained, 239  
 feasible successors, 263-265  
 hello packets, 237-238  
 interfaces  
   *troubleshooting*, 280-286  
   *working interfaces*, 282-284  
 load balancing, 267-269  
 loop avoidance, 244

metric calculation, 269-270  
 metric components, 266-267  
 neighbors, 239-240  
   *troubleshooting*, 289-292  
   *verification checks*, 290-291  
 partial update messages, 237  
 route calculation  
   *bandwidth issues*, 243  
   *example*, 242-243  
   *FD (feasible distance)*, 244-245  
   *metric calculation*, 241  
   *RD (reported distance)*, 244-245  
 self-assessment, 248-249, 274-275  
 successors, 262-263  
 topology table, 261-262  
 troubleshooting  
   *interfaces*, 280-286  
   *neighbors*, 289-292  
   *overview*, 279-280  
 update messages, 240-241  
 variance, 268-269  
 verifying core features of, 255  
   *interfaces*, 256-258  
   *IPv4 routing table*, 259-260  
   *neighbor status*, 258-259  
 wildcard masks, 255

EIGRPv6 (Enhanced Interior Gateway Routing Protocol version 6)  
 bandwidth and delay settings, 464-465  
 basic configuration, 461  
 compared to EIGRPv4, 466-467  
 configuration commands, 462  
 configuration example, 462-464  
 explained, 461  
 interfaces, 467-469  
 IPv6 routes, 472-473  
 load balancing, 465  
 neighbors, 469-470  
 self-assessment, 475-476  
 timers, 466  
 topology database, 470-472

electing root switches via STP (Spanning Tree Protocol), 21-22

emulation, Ethernet, 389

**encapsulation**

- end-to-end, 378
- Frame Relay, 341-342, 356
- encapsulation command, 138, 318, 334, 371
- encapsulation frame-relay command, 353-355, 371, 383
- encapsulation hdlc command, 318
- encapsulation ppp command, 323-324
- encryption
  - encryption keys, 179
  - IPsec, 179-180
- end-to-end encapsulation, 378
- Enhanced Interior Gateway Routing Protocol. *See* EIGRPv4; EIGRPv6
- EoMPLS (Ethernet over MPLS), 389
- equal-cost load balancing, 263
- erase nvram command, 520, 525
- erase startup-config command, 520, 525
- erasing configuration files, 519-520
- EtherChannel, 29-30
  - configuring, 47-48
    - channel-group command options, 57-58*
    - dynamic EtherChannel, 50*
    - interface configuration settings, 58-59*
    - manual EtherChannel, 48-49*
  - troubleshooting, 56
    - channel-group command options, 57-58*
    - interface configuration settings, 58-59*
- Ethernet
  - emulation, 389
  - EoMPLS (Ethernet over MPLS), 389
  - Ethernet WANs (wide area networks), 389-390
  - links, designated routers on, 205-206
  - PPPoE (PPP over Ethernet)
    - configuring, 399-400*
    - explained, 398-399*
- eui-64 keyword, 416
- exam advice
  - Cisco Certification Exam Tutorial, 546-547
  - exam-day advice, 548-549

**Exam Review**

- exam-taking tips, 553-554*
- math-related skills, 549-550*
- practice exams, 551-553*
- hands-on CLI skills, practicing, 556-557
- other study tasks, 558
- pre-exam suggestions, 548
- Question Review, 554-556
- time management, 547-548

**Exam Review**

- math-related skills, 549-550
- practice exams
  - exams, 551-553*
  - exam-taking tips, 553-554*
  - Question Review, 554-556*
- exchanging LSAs with neighbors, 203-204
- extended ping, 119-121
- extended traceroute command, 126-127
- extranet VPNs (virtual private networks), 178

**F****failover, HSRP (Hot Standby Router Protocol), 161-162****FCS (Frame Check Sequence) field, 316****FD (feasible distance), 244-245****feasible successors (EIGRP), 245-246**

- convergence via, 265-266
- creating/viewing, 265
- finding, 263-265

**FHRP (First Hop Redundancy Protocol)**

## benefits of, 159-160

## explained, 156-160

**GLBP (Gateway Load Balancing Protocol)**

- active virtual gateway (AVG), 163*
- configuring, 167-169*
- explained, 160, 163-164*
- verifying, 167-169*

**HSRP (Hot Standby Router Protocol)**

- configuring, 164-167*
- explained, 160-161*
- failover, 161-162*
- load balancing, 162*
- verifying, 164-167*



- need for network redundancy, 157-158
- self-assessment, 170-172
- single points of failure, 157-158
- VRRP (Virtual Router Redundancy Protocol), 160
- filtering**
  - LAN switching, 79-82, 90-91
  - packets with ACLs (access control lists), 151-152
- finding**
  - duplicate OSPF router IDs, 295-296
  - EIGRPv4 feasible successors, 263-265
  - EIGRPv4 successors, 262-263
  - Hello/dead timer mismatches, 296-297
- First Hop Redundancy Protocol. *See* FHRP**
- Flash memory, upgrading IOS software images into, 505-507**
- flows (network), 497**
- Forward Delay timers (STP), 26-28**
- forward routes, 127**
- forwarding**
  - broadcasts in VLAN 3, 97-98
  - IP forwarding, 143-146
  - LAN switches, 11-12, 71-72
  - unicasts, 99-100
- forwarding state (STP), 18-19**
  - DPs (designated ports)
    - choosing, 24-25*
    - explained, 19*
  - reasons for, 20
  - root switches
    - electing, 21-22*
    - explained, 19*
  - RPs (root ports), 29
- Frame Check Sequence (FCS) field, 316**
- Frame Relay, 336-388**
  - access links, 338
    - Layer 1 issues, 370*
    - Layer 2 issues, 371*
  - addressing, 344
  - AR (access rate), 338
  - configuring
    - address mapping, 357-361*
    - encapsulation, 356*
    - fully meshed networks with one IP subnet, 354-355*
    - LMI (Local Management Interface), 356*
    - multipoint subinterfaces, 366-368*
    - OSPF (Open Shortest Path First), 368-369*
    - planning configurations, 353-354*
    - point-to-point subinterfaces, 361-364*
    - self-assessment, 381-382*
    - verification, 364-365*
  - DCE (data communications equipment), 338
  - DLCI (data link connection identifiers), 338
    - explained, 342*
    - frame forwarding, 343-344*
    - local DLCI, 342-343*
  - DTE (data terminal equipment), 337-338, 345
  - encapsulation and framing, 341-342
  - Layer 3 addressing
    - hybrid approach, 347-348*
    - one subnet per VC (virtual circuit), 345-346*
    - single subnets containing all DTE, 345*
  - LMI (Local Management Interface), 337-341
  - NBMA (nonbroadcast multiaccess) networks, 337-338
  - overview, 337-341
  - private WANs, 388
  - PVC (permanent virtual circuits), 338
    - subinterface status, 377*
    - troubleshooting, 372-377*
  - self-assessment, 349-350
  - SVC (switched virtual circuits), 338
  - troubleshooting, 369
    - end-to-end encapsulation, 378*
    - Layer 1 issues on access links, 370*
    - Layer 2 issues on access links, 371*
    - mapping issues, 377-378*
    - mismatched subnet numbers, 379*
    - PVC (permanent virtual circuit) problems, 372-377*

*self-assessment*, 381-382  
*suggested process*, 369-370

- VC (virtual circuits)
  - explained*, 337-340
  - Layer 3 addressing*, 345-346
- frame-relay interface-dlci command, 354-356, 363, 367, 377, 383
- frame-relay inverse-arp command, 383
- frame-relay lmi-type ansi command, 356, 372
- frame-relay lmi-type command, 341, 353, 356, 383
- frame-relay map command, 354, 356, 361, 377, 383
- full-mesh Frame Relay networks, 340
- Full neighbor state (OSPF neighbors), 206
- full update messages, 234-235
- fully adjacent OSPFv2 neighbors, 206
- fully meshed networks with one IP subnet, 354-355

## G

---

- Gateway Load Balancing Protocol. *See* GLBP (Gateway Load Balancing Protocol)
- gateways, active virtual gateway (AVG), 163
- generic routing encapsulation tunnels. *See* GRE tunnels
- GLBP (Gateway Load Balancing Protocol)
  - active virtual gateway (AVG), 163
  - configuring, 167-169
  - explained, 160, 163-164
  - verifying, 167-169
- glbp group ip virtual-ip command, 167
- GRE (generic routing encapsulation) tunnels
  - configuring, 185-187
  - explained, 181-182
  - over unsecured network, 183-184
  - routing over, 182-183
  - tunnel interfaces, 182-184
  - verifying, 187-189

## H

---

### HDLC (High-level Data Link Control)

- leased-line WANs
  - building WAN links*, 315-316
  - CSU/DSU, 315
  - explained*, 311
  - HDLC configuration*, 317-320
  - layer 1 leased lines*, 311-316
  - layer 2 leased lines*, 316-317
  - leased line components*, 312-314
  - T-carrier system*, 314
- overview, 113
- Hello/dead timer mismatches, finding, 296-297
- Hello Interval timer, 204
- hello packets (EIGRP), 237-238
- Hello timers (STP), 26-28
- hexadecimal-to-binary conversion, 566
- high availability campus network design, 159
- High-Level Data Link Control. *See* HDLC
- host IPv4 routing logic, 111-112
- hostname command, 518
- hostnames, pinging, 123-124
- hosts
  - IPv4 routing, troubleshooting
    - DNS problems*, 136-137
    - IP address settings*, 137
    - mismatched IPv4 settings*, 133-134
    - mismatched masks*, 134-135
  - IPv6 hosts, configuring
    - router address*, 415-416
    - stateful DHCPv6*, 413-414
    - stateful SLAAC (stateless address autoconfiguration)*, 414-415
    - static routes*, 416-417
    - verifying connectivity*, 417-420
- Hot Standby Router Protocol. *See* HSRP
- HSRP (Hot Standby Router Protocol)
  - configuring, 164-167
  - explained, 160-161
  - failover, 161-162
  - load balancing, 162
  - verifying, 164-167

**ICMP (Internet Control Message Protocol), 115, 127**

**ICND2 practice exams, 551-552**

**IDs**

- BID (bridge ID), configuring, 39-40
- system ID extension, configuring, 39-40

**IEEE 802.1d. *See* STP (Spanning Tree Protocol)**

**ifconfig command, 417, 433**

**IFS (IOS File System), 520**

**ignoring incoming broadcast frame, 96-97**

**images (IOS)**

- images per feature set combination, 528
- images per model/series, 527
- universal images, 528
- upgrading into Flash memory, 505-507

**inferior hello (STP), 21**

**infinity, 236**

**Integrated Services Digital Network (ISDN), 393-394**

**interarea routes, 208**

**interface loopback command, 229**

**interface serial command, 363, 383**

**interface status codes for LAN switches, 74-75**

**interface tunnel command, 184-186**

**interfaces**

- EIGRPv4 interfaces
  - finding, 256-258*
  - troubleshooting, 280-286*
- EIGRPv6 interfaces, 467-469
- isolating (LAN switching), 73-78, 88-90
  - cabling pinouts, 75*
  - interface status codes, 74-75*
  - notconnect state, 75*
- OSPFv2 interfaces, 280-281, 286-288
- OSPFv3 interfaces
  - troubleshooting, 443-444*
  - verifying, 443*

**Internal routers, 208**

**Internet Access Links, 392**

**Internet Control Message Protocol (ICMP), 115, 127**

**Internet Protocol. *See* IP**

**intra-area routes, 208**

**Inverse ARP, 360**

**IOS file management**

- configuration files, 517-518
  - copying, 519-520*
  - erasing, 519-520*
  - running-config, 517*
  - setup mode, 521*
  - startup-config, 517*

**IOS software**

- boot sequence, 507-508*
- configuration register, 509*
- IOS image verification, 512-513*
- OS selection process, 509-511*
- recovery if IOS does not load, 511*
- three-router operating systems, 505-509*

**password recovery**

- example, 515-517*
- explained, 513-515*

**self-assessment, 505, 523-524**

**IOS File System (IFS), 520**

**IOS packaging**

- explained, 527
- images per feature set combination, 528
- images per model/series, 527
- universal images, 528

**IOS software activation, 529-530**

- boot sequence, 507-508
  - configuration register, 509*
  - IOS image verification, 512-513*
  - OS selection process, 509-511*
  - recovery if IOS does not load, 511*
  - three-router operating systems, 508-509*

**Cisco License Manager (CLM), 530-531**

**images, upgrading into Flash memory, 505-507**

**manual activation**

- activation process, 531-533*
- adding permanent technology package license, 535-536*
- showing current license status, 533-534*

- right-to-use licenses, 536-538
- self-assessment, 540
- IP (Internet Protocol)**
  - default router IP address settings
    - troubleshooting*, 137
  - delivery headers, 184
  - IP forwarding
    - troubleshooting*, 143-146
- ip address command**, 134, 150, 160, 185-186, 318
- IP addressing**
  - binary-to-hexadecimal conversion, 566
  - decimal-to-binary conversion, 563-565
  - hexadecimal-to-binary conversion, 566
- ip domain-lookup command**, 137
- ip flow command**, 497
- ip flow egress command**, 497
- ip flow-export command**, 497
- ip flow-export destination command**, 498
- ip flow-export source command**, 498
- ip flow-export version command**, 498
- ip flow ingress command**, 497
- ip hello-interval eigrp command**, 253, 301, 462
- ip helper-address command**, 140-141
- ip hold-time eigrp command**, 253, 276, 301, 462
- ip mtu command**, 450
- ip name-server command**, 137
- ip ospf cost command**, 223-225, 228, 458
- ip ospf dead-interval command**, 301
- ip ospf hello-interval command**, 301
- ip ospf network point-to-multipoint command**, 368
- ip route command**, 215
- ipbasek9**, 530
- ipconfig command**, 417, 433
- IPCP (IP Control Protocol)**, 321
- IPsec VPNs (virtual private networks)**, 179-180
- IPv4 routing**
  - default router IP address settings, 137
  - delivery headers, 184
- DV (distance vector) routing protocols
  - explained*, 233-234
  - full update messages*, 234-235
  - route poisoning*, 236-237
  - split horizon*, 235-236
- EIGRPv4 (Enhanced Interior Gateway Routing Protocol version 4)**
  - advantages of*, 232
  - autosummarization*, 270-272
  - basic configuration*, 253-254
  - compared to other routing protocols*, 232-233, 238
  - convergence*, 244-247, 265-266
  - development of*, 231
  - discontiguous classful networks*, 271-272
  - DUAL (Diffusing Update Algorithm)*, 246
  - explained*, 239
  - feasible successors*, 263-265
  - hello packets*, 237-238
  - load balancing*, 267-269
  - loop avoidance*, 244
  - metric calculation*, 269-270
  - metric components*, 266-267
  - neighbors*, 239-240
  - partial update messages*, 237
  - route calculation*, 241-245
  - self-assessment*, 248-249, 274-275
  - successors*, 262-263
  - topology table, viewing*, 261-262
  - update messages*, 240-241
  - variance*, 268-269
  - verifying core features of*, 255-260
  - wildcard masks*, 255
- FHRP (First Hop Redundancy Protocol)**.  
See FHRP
- IP forwarding, troubleshooting, 143, 144-146
- normal routing behavior, predicting
  - data link headers*, 114-115
  - host IPv4 routing logic*, 111-112
  - IP routing from host to host*, 113-114
  - IP routing logic on single router*, 112-113
  - sample ARP process*, 115

- OSPFv2 (Open Shortest Path First version 2), 200
  - AD (*administrative distance*), 215-216
  - areas, 206-213
  - basic configuration, 216-217
  - compared to OSPFv3, 441-442
  - compared to other routing protocols, 232-233, 238
  - DRs (*designated routers*), 205-206
  - explained, 201-202
  - fully neighbors, 206
  - load balancing, 225
  - LSAs (*link-state advertisements*), 203-204, 209-213, 222
  - LSDB (*link-state databases*), 204-205
  - metrics, 224-225
  - multi-area configuration, 217-220
  - neighbors, 202-206
  - RID (*router ID*), 202
  - self-assessment, 227
  - single-area configuration, 218-219
  - SPF route calculation, 208, 214-215
  - verifying configuration, 220-223
- OSPFv3 (Open Shortest Path First version 3), 434
  - basic configuration, 435
  - compared to OSPFv2, 441-442
  - default routes, 440-441
  - interface cost, 439-440
  - interfaces, 443-444
  - IPv6 routes, 453-454
  - load balancing, 440
  - LSAs (*link-state advertisements*), 448-451
  - metrics, 451-453
  - multi-area configuration, 435-439
  - neighbors, 445-448
  - self-assessment, 456-457
  - single-area configuration, 436-438
- problem isolation with ping command
  - explained, 115-117
  - hostnames and IP addresses, 123-124
  - LAN neighbors, testing, 121-122
  - longer routes, testing, 117-119
  - reverse routes, testing, 119-121
  - sample output, 116
  - WAN neighbors, testing, 122-123
- problem isolation with traceroute command, 124
  - explained, 124-126
  - extended traceroute, 126-127
  - isolating problems to two routers, 127-129
  - sample output, 125
  - standard traceroute, 126
- protocol troubleshooting
  - duplicate router IDs, 295-296
  - EIGRP interfaces, 280-286
  - EIGRP neighbors, 289-292
  - Hello/dead timer mismatches, 296-297
  - mismatched MTU settings, 299
  - mismatched network types, 297-299
  - OSPF area mismatches, 294
  - OSPF interfaces, 280-281, 286-288
  - OSPF neighbors, 289-290, 293-297
  - overview, 279-280
- RIP-2, 232-233, 238
- routing logic
  - from host to host, 113-114
  - on single router, 112-113
- routing table, displaying, 259-260
- troubleshooting, 110, 132-133
  - ACLs (*access control lists*), 151-152
  - DHCP Relay issues, 140-141
  - DNS problems, 136-137
  - IP address settings, 137
  - IP forwarding, 143-146
  - LAN issues, 141-142
  - mismatched IPv4 settings, 133-134
  - mismatched masks, 134-135
  - mismatched VLAN trunking configuration, 138-140
  - normal routing behavior, predicting, 111-115
  - with ping command, 115-124
  - router WAN interface status, 150-151

- with show ip route command, 144-146*
  - with traceroute command, 124-129*
  - VLSM, 146-150*
- ipv6 address command, 415-416, 426-428, 432**
- ipv6 dhcp relay command, 425**
- ipv6 dhcp relay destination command, 432**
- ipv6 eigrp asn command, 461**
- ipv6 eigrp command, 463, 468, 477**
- ipv6 hello-interval eigrp command, 477**
- ipv6 hold-time eigrp command, 477**
- ipv6 ospf command, 432**
- ipv6 ospf cost command, 440**
- ipv6 ospf hello-interval command, 448**
- ipv6 router eigrp command, 463, 477**
- ipv6 router ospf command, 432**
- IPv6 routing**
  - EIGRPv6 (Enhanced Interior Gateway Routing Protocol version 6)
    - bandwidth and delay settings, 464-465*
    - basic configuration, 460-461*
    - compared to EIGRPv4, 466-467*
    - configuration commands, 462*
    - configuration example, 462-464*
    - explained, 461*
    - interfaces, 467-469*
    - IPv6 routes, 472-473*
    - load balancing, 465*
    - neighbors, 469-470*
    - self-assessment, 475-476*
    - timers, 466*
    - topology database, 470-472*
  - host configuration
    - router address, 415-416*
    - SLAAC (stateless address autoconfiguration), 414-415*
    - stateful DHCPv6, 413-414*
    - static routes, 416-417*
  - IOS packaging
    - explained, 527*
    - images per feature set combination, 528*
    - images per model/series, 527*
    - universal images, 528*
  - IOS software activation, 529-530
    - Cisco License Manager (CLM), 530-531*
    - manual activation, 531-536*
    - right-to-use licenses, 536-538*
    - self-assessment, 540*
  - NetFlow
    - collector, 500*
    - configuring, 497-498*
    - explained, 495-497*
    - network flows, 497*
    - verifying, 498-499*
  - SNMP (Simple Network Management Protocol)
    - community strings, 490*
    - explained, 487-488*
    - MIB (Management Information Base), 488-489*
    - SNMP version 2c, 490-491*
    - SNMP version 3, 491*
    - traps, 488*
  - subnetting, 411-413
  - Syslog (System Message Logging)
    - configuring, 494-495*
    - explained, 492*
    - Syslog server, 495*
    - system message format, 493*
    - system message severity levels, 494*
    - verifying, 494-495*
  - troubleshooting
    - DNS issues, 424*
    - ping failures, 421-423*
    - SLAAC issues, 425-426*
    - stateful DHCP, 424-425*
    - traceroute failures, 427-429*
  - unicast IPv6 addresses, 411-413
  - verifying connectivity
    - from hosts, 417-418*
    - from routers, 419-420*
  - ipv6 unicast-routing command, 415, 426, 432**
  - ISDN (Integrated Services Digital Network), 393-394**
  - isolating**
    - IPv4 routing problems
      - ping command, 115-124*
      - traceroute command, 124-129*

- LAN switching interface problems, 68-69, 73-78, 88-90
  - cabling pinouts*, 75
  - interface status codes*, 74-75
  - notconnect state*, 75
- VLAN and trunking problems, 15, 82-86, 92-94

## K-L

---

- keepalive command, 383
- keepalive failure, troubleshooting, 327
- LAN neighbors, testing with ping, 121-122
- LAN switching
  - DPs (designated ports)
    - choosing*, 24-25
    - explained*, 19
  - overview, 11
  - root cost, 19
  - root switches
    - electing*, 21-22
    - explained*, 19
  - router LAN issues, troubleshooting, 141-142
  - RPs (root ports)
    - choosing*, 23-24
    - explained*, 19
  - STP (Spanning Tree Protocol). *See* STP
  - switch verification, 12
    - determining VLAN of frames*, 13-15
    - switch reactions to changes with STP*, 26-28
    - verifying trunks*, 15
    - viewing MAC address table*, 12-13
  - troubleshooting, 64-65
    - analyzing/predicting normal operation*, 65-68
    - ARP requests (broadcast), forwarding path of*, 95-98
    - cabling pinouts*, 75
    - control plane analysis*, 67-68
    - data plane analysis*, 66-67
    - duplex issue*, 77-78
    - exam tips*, 70

- example of*, 91
- forwarding process overview*, 11-12, 71-72
- interface status codes*, 74
- isolate filtering/port security problems*, 79-82, 90-91
- isolation of interface problems*, 73-78, 88-90
- isolation of VLAN/trunking problems*, 15, 82-86, 92-94
- network diagram confirmation via CDP*, 72-73, 87-88
- notconnect state*, 75
- problem isolation*, 68-69
- R1 ARP Reply (unicast), forwarding path of*, 98-101
- root cause analysis*, 69-70
- switch interface speed and duplex*, 76-77
- switch interface speeds*, 77-78

- layer 1 leased lines, 311-316**
  - building WAN links, 315-316
  - CSU/DSU, 315
  - physical components, 312-314
  - T-carrier system, 314-315
  - troubleshooting, 325-326
- layer 2 leased lines, 316-317, 326**
- layer 3 leased lines, 329-330**
- LCP (Link Control Protocol), 321-323**
- Learning state (STP), 28**
- leased line WANs (wide area networks)**
  - HDLC (High-level Data Link Control)
    - building WAN links*, 315-316
    - CSU/DSU, 315
    - explained*, 311
    - HDLC configuration*, 317-320
    - layer 1 leased lines*, 311-316
    - layer 2 leased lines*, 316-317
    - leased line components*, 312-314
    - T-carrier system*, 314
  - PPP (Point-to-Point Protocol)
    - authentication*, 322-323
    - CHAP (Challenge Handshake Authentication Protocol)*, 324-325, 328-329
    - configuring*, 323-324
    - explained*, 320-321
    - framing*, 321

- LCP (Link Control Protocol)*, 321-322
  - NCP (Network Control Protocols)*, 321
  - self-assessment, 332-333
  - troubleshooting
    - keepalive failure*, 327
    - layer 1 problems*, 325-326
    - layer 2 problems*, 326
    - layer 3 problems*, 329-330
    - PAP/CHAP authentication failure*, 328-329
  - leased lines, 387-388
  - license boot module command, 537, 541
  - license install command, 541
  - licensing (IOS), 526
    - IOS packaging
      - images per feature set combination*, 528
      - images per model/series*, 527
      - universal images*, 528
    - IOS software activation, 529-530
      - Cisco License Manager (CLM)*, 530-531
      - manual activation*, 531-536
      - right-to-use licenses*, 536-538
    - license status, showing, 533-534
    - permanent technology package license, adding, 535-536
    - self-assessment, 540
  - line status, 74
  - Link Control Protocol (LCP), 321
  - link-local addresses, 413
  - link-state advertisements. *See* LSAs
  - link-state databases (LSDB), 204-205
  - Link-State Update (LSU), 204, 234
  - Listening state (STP), 28
  - LMI (Local Management Interface), 337-341, 356
  - load balancing
    - EIGRPv4 (Enhanced Interior Gateway Routing Protocol version 4), 267-269
    - EIGRPv6 (Enhanced Interior Gateway Routing Protocol version 6), 465
    - HSRP (Hot Standby Router Protocol), 162
    - OSPFv2 (Open Shortest Path First version 2), 225
    - OSPFv3 (Open Shortest Path First version 3), 440
    - PSVT+ (Per-VLAN Spanning Tree Plus), 38
  - local DLCI (data link connection identifiers), 342-343
  - local loop, 393
  - Local Management Interface (LMI), 337-341, 356
  - logging buffered command, 494
  - logging console command, 494
  - logging with Syslog (System Message Logging)
    - configuring, 494-495
    - explained, 492
    - Syslog server, 495
    - system message format, 493
    - system message severity levels, 494
    - verifying, 494-495
  - Long-Term Evolution (LTE), 397
  - loop avoidance, 244
  - LSAs (link-state advertisements)
    - exchanging with neighbors, 203-204
    - explained, 209-210
    - in multi-area design, 212-213
    - network LSAs, 211-212
    - OSPFv3 LSAs
      - troubleshooting*, 450-451
      - verifying*, 448-450
    - router LSAs, 210
    - verifying, 222
  - LSDB (link-state databases), 204-205
  - LSUs (Link-State Update), 204, 234
  - LTE (Long-Term Evolution), 397
- 
- ## M
- 
- MAC address table
    - STP (Spanning Tree Protocol), 17
    - viewing, 12-13
  - maintaining OSPFv2 neighbors, 204-205
  - Management Information Base (MIB), 488-489



**manual software activation, 531-533**  
   adding permanent technology package license, 535-536  
   showing current license status, 533-534  
**mapping addresses (Frame Relay), 357-359**  
   Inverse ARP, 360  
   static mapping, 360-361  
   troubleshooting, 377-378  
**math-related skills, 549-550**  
**Max Age timers (STP), 26-28**  
**maximum-paths command, 225, 229, 253, 267-269, 276, 440, 462, 465, 477**  
**memory (Flash), upgrading IOS software images into, 505-507**  
**message logging. See Syslog**  
**metric calculation (EIGRP), 241-243**  
**metrics**  
   EIGRPv4 (Enhanced Interior Gateway Routing Protocol version 4), 266-270  
   OSPFv2 (Open Shortest Path First version 2)  
     *interface costs, 224*  
     *reference bandwidth, 225*  
**MetroE (Metropolitan Ethernet), 389**  
**MIB (Management Information Base), 488-489**  
**microseconds, 242**  
**mismatched IPv4 settings, 133-134**  
**mismatched masks, 134-135**  
**mismatched MTU settings, 299**  
**mismatched OSPF network types, 297-299**  
**mismatched subnet numbers, 379**  
**mobile phone 3G/4G access, 397-398**  
**MPLS (Multiprotocol Label Switching), 390-391**  
**MTU settings, troubleshooting, 299**  
**multi-area design, LSAs (link-state advertisements) in, 212-213**  
**multi-area OSPFv2 configuration, 217-223**  
**multi-area OSPFv3 configuration, 435-439**  
**multiple frame transmission, 17**

**multipoint subinterfaces, Frame Relay configuration, 366-368**  
**Multiprotocol Interconnect over Frame Relay, 342**  
**Multiprotocol Label Switching (MPLS), 390-391**

## N

---

**name resolution (DNS), 123**  
**NBMA (nonbroadcast multiaccess) networks, 337-338**  
**NDP (Neighbor Discovery Protocol), 413**  
**neighbors**  
   EIGRPv4 neighbors, 239-240  
     *displaying status of, 258-259*  
     *troubleshooting, 289-292*  
     *verification checks, 290-291*  
   EIGRPv6 neighbors, 469-470  
   OSPFv2 neighbors  
     *adjacent neighbors, 206*  
     *area mismatches, 294*  
     *duplicate router IDs, 295-296*  
     *exchanging LSAs (link-state advertisement) with neighbors, 203-204*  
     *Hello/dead timer mismatches, 296-297*  
     *forming neighbor relationships, 202-203*  
     *fully adjacent neighbors, 206*  
     *LSDB (link-state databases), 204-205*  
     *maintaining, 204-205*  
     *states, 206*  
     *troubleshooting, 289-290, 293-297*  
   OSPFv3 neighbors  
     *troubleshooting, 446-448*  
     *verifying, 445-446*  
**NetFlow**  
   collector, 500  
   configuring, 497-498  
   explained, 495-497  
   network flows, 497  
   verifying, 498-499  
**netsh interface ipv6 show neighbors command, 433**

- network area command, 217, 435
- network command, 228, 253-255, 276, 280, 458, 461-462
- network diagrams, confirming via CDP (LAN switching), 72-73, 87-88
- network flows, 497
- network LSAs (link-state advertisements), 211-212
- network management
  - configuration files, 517-518
    - copying*, 519-520
    - erasing*, 519-520
    - running-config*, 517
    - setup mode*, 521
    - startup-config*, 517
  - IOS software
    - boot sequence*, 507-513
    - upgrading images into Flash memory*, 505-507
  - NetFlow
    - collector*, 500
    - configuring*, 497-498
    - explained*, 495-497
    - network flows*, 497
    - verifying*, 498-499
  - password recovery
    - example*, 515-517
    - explained*, 513-515
  - self-assessment, 502-503
  - SNMP (Simple Network Management Protocol)
    - community strings*, 490
    - explained*, 487-488
    - MIB (Management Information Base)*, 488-489
    - SNMP version 2c*, 490-491
    - SNMP version 3*, 491
    - traps*, 488
  - Syslog (System Message Logging)
    - configuring*, 494-495
    - explained*, 492
    - Syslog server*, 495
    - system message format*, 493
    - system message severity levels*, 494
    - verifying*, 494-495
- Network Management Station (NMS), 487
- network types (OSPF), troubleshooting, 297-299
- NMS (Network Management Station), 487
- no auto-summary command, 272, 276
- no cdp enable command, 73
- no cdp run command, 73
- no frame-relay inverse-arp command, 383
- no frame-relay lmi-type command, 372, 383
- no ip domain-lookup command, 137
- no ipv6 eigrp 1 command, 469
- no keepalive command, 365
- no logging buffered command, 494
- no logging console command, 494
- no passive-interface command, 229, 277
- no shutdown command, 59, 80-81, 91, 318, 334, 477
- no shutdown vlan command, 84
- noAuthNoPriv security level, 492
- nonbroadcast multiaccess (NBMA) networks, 337-338
- notconnect state (LAN switches), 75
- numeric reference table
  - binary-to-hexadecimal conversion, 566
  - decimal-to-binary conversion, 563-565
  - hexadecimal-to-binary conversion, 566

## O

---

- Open Shortest Path First. *See* OSPFv2; OSPFv3
- operating systems
  - selection process, 509-511
  - three-router operating systems, 508-509
- OSPFv2 (Open Shortest Path First version 2), 200
  - AD (administrative distance), 215-216
  - areas
    - design advantages*, 209
    - design rules*, 207
    - design terminology*, 207-208
    - explained*, 206-207

- intra-area topology, 210-212*
- multi-area design, 212-213*
- reducing SPF calculation time with, 208*
- single-area OSPF, 206*
- basic configuration, 216-217
- compared to OSPFv3, 441-442
- compared to other routing protocols, 232-233, 238
- DRs (designated routers), 205-206
- explained, 201-202
- Frame Relay configuration, 368-369
- load balancing, 225
- LSAs (link-state advertisements)
  - exchanging with neighbors, 203-204*
  - explained, 209-210*
  - in multi-area design, 212-213*
  - network LSAs, 211-212*
  - router LSAs, 210*
  - verifying, 222*
- LSDB (link-state databases), 204-205
- metrics
  - interface cost, 224*
  - reference bandwidth, 225*
- multi-area configuration, 217-220
- neighbors
  - adjacent neighbors, 206*
  - area mismatches, 294*
  - duplicate router IDs, 295-296*
  - exchanging LSAs with neighbors, 203-204*
  - forming neighbor relationships, 202-203*
  - Hello/dead timer mismatches, 296-297*
  - maintaining, 204-205*
  - states, 206*
  - troubleshooting, 293-297*
- RID (router ID), 202
- self-assessment, 227
- single-area configuration, 218-219
- SPF route calculation
  - calculating best routes, 214-215*
  - reducing calculation time with areas, 208*

- troubleshooting
  - area mismatches, 294*
  - duplicate router IDs, 295-296*
  - Hello/dead timer mismatches, 296-297*
  - interfaces, 280-281, 286-288*
  - mismatched MTU settings, 299*
  - mismatched network types, 297-299*
  - neighbors, 289-297*
  - network types, 297-299*
  - overview, 279-280*
- verifying configuration, 220-223
  - areas, 221*
  - DRs (dedicated routers) and BDRs (backup DRs), 221-222*
  - LSAs (link-state advertisements), 222*
  - OSPF routes, 223*
- OSPFv3 (Open Shortest Path First Version 3), 434**
  - basic configuration, 435
  - compared to OSPFv2, 441-442
  - default routes, 440-441
  - interfaces, 443
    - cost, 439-440*
    - troubleshooting, 443-444*
    - verifying, 443*
  - IPv6 routes, troubleshooting, 453-454
  - load balancing, 440
  - LSAs (link-state advertisements)
    - troubleshooting, 450-451*
    - verifying, 448-450*
  - metrics, verifying, 451-453
  - multi-area configuration, 435-439
  - neighbors
    - troubleshooting, 446-448*
    - verifying, 445-446*
  - self-assessment, 456-457
  - single-area configuration, 436-438
- overlapping subnets**
  - configuring, 149-150
  - with VLSM, 148-149
  - without VLSM, 147-148

## P

---

- packaging (IOS)**
  - explained, 527
  - images per feature set combination, 528
  - images per model/series, 527
  - universal images, 528
- packet filtering with ACLs (access control lists), 151-152**
- PAP/CHAP authentication failure, 328-329**
- partial-mesh networks, 340**
- partial update messages, 237**
- passive-interface command, 229, 257, 277, 280-281, 285, 301, 444**
- passive-interface default command, 229, 277**
- password recovery**
  - example, 515-517
  - explained, 513-515
- periodic update messages, 234**
- permanent virtual circuits (PVC), 338, 372-377**
- Per-VLAN Spanning Tree Plus (PVST+), 38**
- PID (product ID), 531**
- ping command, 418-419, 432-433**
  - extended ping
    - LAN neighbors, testing, 122*
    - reverse routes, testing, 119-121*
  - IPv4 testing
    - explained, 115-117*
    - with hostnames and IP addresses, 123-124*
    - LAN neighbors, 121-122*
    - longer routes, 117-119*
    - reverse routes, 119-121*
    - sample output, 116*
    - WAN neighbors, 122-123*
  - troubleshooting in IPv6, 421-423
- ping6 command, 418, 433**
- pinouts (cabling) for LAN switches, 75**
- point of presence (PoP), 393**
- Point-to-Point Protocol. *See* PPP**
- point-to-point subinterfaces, configuring, 361-364**
- point-to-point WANs (wide area networks)**
  - HDLC (High-level Data Link Control)**
    - building WAN links, 315-316*
    - CSU/DSU, 315*
    - explained, 311*
    - HDLC configuration, 317-320*
    - layer 1 leased lines, 311-316*
    - layer 2 leased lines, 316-317*
    - leased line components, 312-314*
    - T-carrier system, 314*
  - PPP (Point-to-Point Protocol)**
    - authentication, 322-323*
    - CHAP (Challenge Handshake Authentication Protocol), 324-329*
    - configuring, 323-324*
    - explained, 320-321*
    - framing, 321*
    - LCP (Link Control Protocol), 321-322*
    - NCP (Network Control Protocols), 321*
  - troubleshooting
    - keepalive failure, 327*
    - layer 1 problems, 325-326*
    - layer 2 problems, 326*
    - layer 3 problems, 329-330*
    - PAP/CHAP authentication failure, 328-329*
- PoP (point of presence), 393**
- PortFast, 30, 46-47**
- ports**
  - DPs (designated ports)**
    - choosing, 24-25*
    - determining, 54-55*
    - explained, 19*
    - strategies for DP exam questions, 55-56*
  - port costs, 25-26
  - RPs (root ports)**
    - choosing, 23-24*
    - determining, 52*
    - explained, 19*
    - STP tiebreakers when choosing RP, 53-54*
    - strategies for RP exam questions, 54*

## security

*configuring on Cisco Catalyst switches, 80*

*LAN switching, 79-82, 90-91*

STP (Spanning Tree Protocol) port cost, 43-45

**powers of 2 numeric reference table, 567**

**ppp authentication command, 334**

**PPP (Point-to-Point Protocol)**

LCP authentication, 323

leased-line WANs

*authentication, 322-323*

*CHAP (Challenge Handshake Authentication Protocol), 324-329*

*configuring, 323-324*

*explained, 320-321*

*framing, 321*

*LCP (Link Control Protocol), 321-322*

*NCP (Network Control Protocols), 321*

**PPPoE (PPP over Ethernet)**

configuring, 399-400

explained, 398-399

**pppoe-client command, 400**

**practice exams, 551-553**

exam-taking tips, 553-554

Question Review, 554-556

**predicting normal IPv4 routing behavior**

data link headers, 114-115

host IPv4 routing logic, 111-112

IP routing from host to host, 113-114

IP routing logic on single router, 112-113

sample ARP process, 115

**pre-exam suggestions (Cisco Certification Exam), 548**

**PRI (Primary Rate Interface), 394**

**Primary Rate Interface (PRI), 394**

**priority of switches, configuring, 45-46**

**private WANs (wide area networks)**

explained, 387

Frame Relay, 388

leased lines, 387-388

**problem isolation**

IPv4 routing problems

*ping command, 115-124*

*traceroute command, 124-129*

LAN switching, 68-69

**product ID (PID), 531**

**protocol status, 74**

**protocols. See specific protocols**

**public WANs (wide area networks)**

3G/4G mobile phone access, 397-398

Cable Internet, 396

dial access with modems and ISDN, 393-394

DSL (digital subscriber line), 395-396

Internet Access Links, 392

PPPoE (PPP over Ethernet)

*configuring, 399-400*

*explained, 398-399*

**PVC (permanent virtual circuits)**

Frame Relay, 338

status codes, 376

subinterface status, 377

troubleshooting in Frame Relay, 372-377

**PVST+ (Per-VLAN Spanning Tree Plus), 38**

## Q

---

**query/reply process (EIGRP), 246-247**

**Question Review, 554-556**

**question types (Cisco Certification Exam), 546-547**

## R

---

**Rapid Spanning Tree Protocol (RSTP), 29-31**

**RD (reported distance), 244-245**

**read-only (RO) community strings, 490**

**read-write (RW) community strings, 490**

**recovering**

passwords

*example, 515-517*

*explained, 513-515*

recovery if IOS does not load, 511

- redundancy.** *See* FHRP (First Hop Redundancy Protocol)
- reference bandwidth,** 224-225
- Relay (DHCP), troubleshooting,** 140-141
- releases,** 527
- Reliable Transport Protocol (RTP),** 240
- reload command,** 519, 525
- remote-access VPNs (virtual private networks),** 178
- replies (ARP), forwarding path of,** 98-101
- reported distance (RD),** 244-245
- requests**
- ARP requests (broadcast), forwarding path of, 95-98
  - ICMP Echo Requests, 127
- resetting passwords**
- example, 515-517
  - explained, 514-515
- reverse routes,** 127
- RID (router ID),** 202
- right-to-use licenses,** 536-538
- RIP steady-state operations,** 234-235
- RIP-2,** 232-233, 238
- RO (read-only) community strings,** 490
- ROAS (Router on a Stick),** 138-140
- ROMMON mode,** 508, 514-515
- root cause analysis,** 69-70
- root cost,** 19
- root ports (RPs)**
- choosing, 23-24
  - determining, 52
  - explained, 19
  - STP tiebreakers when choosing RP, 53-54
  - strategies for RP exam questions, 54
- root switches**
- determining, 51-52
  - electing via STP, 21-22
- route calculation (EIGRPv4)**
- bandwidth issues, 243
  - example, 242-243
  - FD (feasible distance), 244-245
  - metric calculation, 241
  - RD (reported distance), 244-245
- route poisoning,** 236-237
- route redistribution,** 215
- router eigrp command,** 253-254, 276, 286, 462
- router ID (RID),** 202
- router-id command,** 202, 216, 229, 435-437, 458
- router LSAs (link-state advertisements),** 210
- Router on a Stick (ROAS),** 138-140
- router ospf command,** 216, 228, 286, 435, 458
- routers**
- active virtual gateway (AVG), 163
  - address configuration, 415-416
  - clock speed, 316-317
  - FHRP (First Hop Redundancy Protocol). *See* FHRP
  - for VPNs (virtual private networks), 179
- routing.** *See* IPv4 routing; IPv6 routing
- routing table (IPv4), displaying,** 259-260
- RPs (root ports)**
- choosing, 23-24
  - determining, 52
  - explained, 19
  - STP tiebreakers when choosing RP, 53-54
  - strategies for RP exam questions, 54
- RSTP (Rapid Spanning Tree Protocol),** 29-31
- RTP (Reliable Transport Protocol),** 240
- running-config,** 517
- RW (read-write) community strings,** 490
- RxBoot operating system,** 508

## S

---

### scalability

- OSPFv2 with areas
  - design advantages,* 209
  - design rules,* 207
  - design terminology,* 207-208
  - explained,* 206-207
  - intra-area topology,* 210-212
  - multi-area design,* 212-213
  - reducing SPF calculation time with,* 208
  - single-area OSPF,* 206
- VPNs (virtual private networks), 179

- Secure Shell (SSH), 115
- Secure Socket Layer (SSL) VPNs, 181
- security
  - port security, 79-82, 90-91
  - VPNs (virtual private networks), 177
- securityk9, 530
- self-assessments
  - EIGRPv4 (Enhanced Interior Gateway Routing Protocol version 4), 248-249, 274-275
  - EIGRPv6 (Enhanced Interior Gateway Routing Protocol version 6), 475-476
  - FHRP (First Hop Redundancy Protocol), 170-172
  - Frame Relay, 349-350, 381-382
  - IOS file management, 505, 523-524
  - IOS licensing, 540
  - leased-line WANs, 332-333
  - network management, 502-503
  - OSPFv2 (Open Shortest Path First version 2), 227
  - OSPFv3 (Open Shortest Path First version 3), 456-457
  - STP (Spanning Tree Protocol), 32-34, 60-61
  - VPNs (virtual private networks), 190-191
  - WAN (wide area network) technologies, 402
- serial cables, 313
- serial links, troubleshooting, 325
  - keepalive failure, 327
  - layer 1 problems, 325-326
  - layer 2 problems, 326
  - layer 3 problems, 329-330
  - PAP/CHAP authentication failure, 328-329
- serial number (SN), 531
- servers, Syslog, 495
- service providers, 312
- session keys, 180
- setup command, 521, 525
- setup mode, 521
- severity levels (Syslog), 494
- shared keys, 180
- shared session keys, 180
- show access-lists command, 152
- show arp command, 137
- show cdp command, 73
- show cdp entry command, 73, 87
- show cdp neighbors command, 73, 87
- show cdp neighbors detail command, 73
- show command, 92, 463
- show controllers command, 319
- show controllers serial command, 318, 335
- show etherchannel command, 48, 63
- show etherchannel summary command, 58
- show flash command, 507, 525
- show frame-relay lmi command, 371-372, 383
- show frame-relay map command, 359-360, 365, 368, 375, 378, 384
- show frame-relay pvc command, 359, 365, 374-376, 383
- show glbp brief command, 167-168
- show glbp command, 169
- show interface switchport command, 83-85
- show interfaces command, 74-78, 89, 224, 241, 269, 301, 324, 334, 379, 383-384
- show interfaces description command, 74, 142-143, 301, 320
- show interfaces status command, 13-15, 74-77, 88
- show interfaces trunk command, 15, 84
- show interfaces tunnel command, 187
- show ip access-lists command, 152
- show ip cache flow command, 499
- show ip eigrp interface command, 257, 287
- show ip eigrp interfaces command, 256, 277, 280-286, 301
- show ip eigrp interfaces detail command, 256, 277
- show ip eigrp neighbors command, 258, 277, 290, 301
- show ip eigrp topology all-links command, 265
- show ip eigrp topology command, 241, 261-266, 277
- show ip flow export command, 499
- show ip flow interface command, 499

- show ip interface brief command, 187, 288, 320, 334, 379, 384
- show ip interface command, 151
- show ip interfaces command, 151-152
- show ip ospf command, 229, 301, 458
- show ip ospf interface brief command, 287
- show ip ospf database command, 209, 222, 229, 459
- show ip ospf interface brief command, 221, 229, 281, 286, 301, 458
- show ip ospf interface command, 221-222, 229, 296, 301, 459
- show ip ospf neighbor command, 202-203, 206, 222, 229, 293, 301, 459
- show ip protocols command, 221, 229, 256-259, 277, 280, 282-288, 291, 301, 459
- show ip route command, 144-145, 188, 216, 229, 260, 271, 277, 459, 465
  - command output, 145-146
  - finding best route with, 145
  - overlapping routes, 144
- show ip route eigrp command, 259-260, 284, 301
- show ip route ospf command, 144, 229, 301, 459
- show ip route | section command, 277
- show ipv6 eigrp interfaces command, 467-468, 477
- show ipv6 eigrp interfaces detail command, 478
- show ipv6 eigrp neighbors command, 469-470, 478
- show ipv6 eigrp topology command, 471, 478
- show ipv6 eigrp topology | section command, 478
- show ipv6 interface command, 429, 432
- show ipv6 neighbors command, 420, 432
- show ipv6 ospf command, 432, 453
- show ipv6 ospf database command, 432
- show ipv6 ospf interface brief command, 432, 443-444, 453
- show ipv6 ospf interface command, 443-444, 448
- show ipv6 ospf neighbor command, 432, 445-447, 451
- show ipv6 protocols command, 432, 443, 468-470, 478
- show ipv6 route command, 432, 465, 478
- show ipv6 route eigrp command, 478
- show ipv6 route ospf command, 452
- show ipv6 route | section command, 478
- show ipv6 routers command, 432
- show license command, 534, 537
- show license feature command, 534, 541
- show license udi command, 531-532, 541
- show logging command, 494-495
- show mac address-table command, 13, 83, 100
- show mac address-table dynamic command, 12, 83, 100
- show port-security command, 90
- show port-security interface command, 79-81
- show running-config command, 47, 152, 256, 318, 443, 518, 525
- show spanning-tree bridge command, 46, 63
- show spanning-tree command, 42, 49-56, 63
- show spanning-tree interface command, 63
- show spanning-tree root command, 42, 46, 51-52, 63
- show spanning-tree vlan command, 41-42, 51, 63, 84, 95
- show standby brief command, 165-166
- show standby command, 166-167
- show startup-config command, 518
- show version command, 512-513, 534-536, 541
- show vlan brief command, 14, 83
- show vlan command, 14, 83
- show vlan id command, 83
- shutdown command, 59, 81, 91, 334, 477
- Simple Network Management Protocol.
  - See SNMP
- single-area OSPF (Open Shortest Path First), 206
  - single-area OSPFv2 configuration, 218-219
  - single-area OSPFv3 configuration, 436-438



- single points of failure, 157-158
- site-to-site VPNs (virtual private networks), 177-178
- SLAAC (stateless address autoconfiguration), 411, 414-415, 425-426
- SMARTnet, 529
- SN (serial number), 531
- SNMP (Simple Network Management Protocol)
  - community strings, 490
  - explained, 487-488
  - MIB (Management Information Base), 488-489
  - SNMP version 2c, 490-491
  - SNMP version 3, 491
  - traps, 488
- snmp-server community command, 490
- snmp-server contact command, 490
- snmp-server location command, 490
- SNMPGET utility, 489
- software activation (IOS), 529-530
  - Cisco License Manager (CLM), 530-531
  - manual activation
    - activation process*, 531-534
    - adding permanent technology package license*, 535-536
  - right-to-use licenses, 536-538
  - self-assessment, 540
- spanning tree algorithm (STA), 19
- Spanning Tree Protocol. *See* STP
- spanning-tree bpduguard default command, 47
- spanning-tree bpduguard disable command, 47, 63
- spanning-tree bpduguard enable command, 46-47, 63
- spanning-tree cost command, 56
- spanning-tree mode command, 62
- spanning-tree mode mst command, 38
- spanning-tree mode pvst command, 38
- spanning-tree mode rapid-pvst command, 38
- spanning-tree portfast bpduguard default command, 63
- spanning-tree portfast command, 46-47, 63
- spanning-tree portfast default command, 47, 63
- spanning-tree portfast disable command, 47, 63
- spanning-tree vlan vlan-id priority value command, 45
- spanning-tree vlan vlan\_id priority x command, 39, 62
- spanning-tree vlan vlan-id root primary command, 45
- spanning-tree vlan vlan-id root secondary command, 45
- spanning-tree vlan vlan-number port-priority priority command, 62
- spanning-tree vlan vlan-number root secondary command, 62
- spanning-tree vlan x cost command, 40, 43-44, 62
- speed command, 77
- SPF route calculation
  - calculating best routes, 214-215
  - reducing calculation time with areas, 208
- split horizon, 235-236
- SSH (Secure Shell), 115
- SSL (Secure Socket Layer) VPNs, 181
- STA (spanning tree algorithm), 19
- standby command, 164
- startup-config, 517
- stateful DHCPv6, 413-414, 424-425
- stateless address autoconfiguration (SLAAC), 411, 414-415, 425-426
- states of OSPFv2 neighbors, 206
- static address mapping, 360-361
- static router configuration (IPv6), 416-417
- steady-state networks (STP), 26
- steady-state operations (RIP), 234-235
- STP (Spanning Tree Protocol), 10, 36
  - BID (bridge ID), 20
  - blocking state, 18-20
  - BPDU (bridge protocol data units), 20-21
  - BPDU Guard feature, 30-31
  - broadcast storms, 16-17
  - configuring
    - BID (bridge ID)*, 39-40
    - BPDU Guard*, 46-47

- defaults and configuration options*, 40
- EtherChannel*, 47-50
- per-VLAN configuration settings*, 38-39
- per-VLAN costs*, 40
- port costs*, 44
- PortFast*, 46-47
- STP mode*, 37-38
- STP port costs*, 43-45
- switch priority*, 44-46
- system ID extension*, 39-40
- convergence, 19, 28
  - delays*, 28
  - troubleshooting*, 56
- DPs (designated ports)
  - choosing*, 24-25
  - determining*, 54-55
  - explained*, 19
  - strategies for DP exam questions*, 55-56
- EtherChannel, 29-30
  - explained, 15-16
- forwarding state, 18-19
  - reasons for*, 20
  - root switches*, 19-22
- interface state changes, 28-29
- Learning state, 28
- Listening state, 28
- MAC table instability, 17
- multiple frame transmission, 17
- need for, 16-17
- port costs, 25-26
- PortFast, 30
- PSVT+ (Per-VLAN Spanning Tree Plus), 38
- root switches
  - determining*, 51-52
  - electing*, 21-22
- RPs (root ports)
  - choosing*, 23-24
  - determining*, 52
  - explained*, 19
  - STP tiebreakers when choosing RP*, 53-54
  - strategies for RP exam questions*, 54
- RSTP (Rapid Spanning Tree Protocol), 29-31
  - self-assessment, 32-34, 60-61
- STA (spanning tree algorithm), 19
- state comparison table, 28
- steady-state networks, 26
- timers, 26-28
- topology
  - influencing with configuration changes*, 25-26
  - interface state changes*, 28-29
  - reacting to state changes that affect STP topology*, 26
  - simple STP tree*, 18-19
  - switch reactions to changes with STP*, 26-28
- troubleshooting, 51
  - convergence*, 56
  - DPs (designated ports)*, 54-56
  - EtherChannel*, 56-59
  - root switches*, 51-52
  - RPs (root ports)*, 52-54
- verifying default operation, 42
- verifying STP operation, 40-43
- subinterfaces, 346**
  - multipoint subinterfaces, 366-368
  - point-to-point subinterfaces, configuring, 361-364
- subnet masks, troubleshooting, 134-135**
- subnets, 549-550**
  - Frame Relay networks
    - fully meshed networks with one IP subnet*, 354-355
    - hybrid Layer 3 addressing*, 347-348
    - one subnet containing all Frame Relay DTEs*, 345
    - one subnet per VC*, 345-346
- IPv6, 411-413
- mismatched masks, troubleshooting, 134-135
- mismatched subnet numbers, troubleshooting, 379
- overlapping subnets
  - configuring*, 149-150
  - with VLSM*, 148-149
  - without VLSM*, 147-148

successors (EIGRP), 245-246  
     feasible successors, 265  
     finding, 262-263  
 superior hello (STP), 21  
 SVC (switched virtual circuits), 338  
 switch priority, configuring, 45-46  
 switch verification (LAN)  
     determining VLAN of frames, 13-15  
     verifying trunks, 15  
     viewing MAC address table, 12-13  
 switchport access vlan command, 83, 92, 140  
 switchport mode access command, 82, 140  
 switchport mode trunk command, 82, 139  
 switchport port-security command, 82  
 switchport port-security mac-address command, 82, 100  
 switchport port-security mac-address sticky command, 82  
 switchport port-security violation command, 79, 82  
 switchport trunk allowed vlan command, 84  
 switchport trunk mode command, 85  
 switchport trunk native vlan command, 139  
 Syslog (System Message Logging)  
     configuring, 494-495  
     explained, 492  
     Syslog server, 495  
     system message format, 493  
     system message severity levels, 494  
     verifying, 494-495  
 system ID extension, configuring, 39-40  
 System Message Logging. *See* Syslog

## T

---

T-carrier system, 314  
 tables, MAC address tables, 12-13, 17  
 TDM (time-division multiplexing), 314  
 tens-of-microseconds, 242  
 testing IPv4 routing with ping command  
     with hostnames and IP addresses, 123-124

LAN neighbors, 121-122  
 longer routes, 117-119  
 reverse routes, 119-121  
 WAN neighbors, 122-123  
 time burners, 547  
 time-division multiplexing (TDM), 314  
 time management (Cisco Certification Exam), 547-548  
 Time To Live (TTL), 125  
 Time-to-Live Exceeded (TTL Exceeded), 125  
 timers  
     Dead Interval, 204  
     EIGRPv6, 466  
     Hello/dead timer mismatches, 296-297  
     Hello Interval, 204  
 topology table  
     EIGRPv4  
         *convergence*, 265-266  
         *feasible successor routes*, 263-265  
         *successor routes*, 262-263  
         *viewing*, 261-262  
     EIGRPv6, 470-472  
 traceroute command, 124, 418-419, 432-433  
     explained, 124-126  
     extended traceroute, 126-127  
     GRE (generic routing encapsulation) tunnels, verifying, 188  
     isolating problems to two routers, 127-129  
     sample output, 125  
     standard traceroute, 126  
     troubleshooting in IPv6, 427-429  
 traceroute6 command, 433  
 traps (SNMP), 488  
 Triple DES (3DES), 180  
 troubleshooting  
     CHAP (Challenge Handshake Authentication Protocol), 328-329  
     EIGRPv4 (Enhanced Interior Gateway Routing Protocol version 4)  
         *interfaces*, 280-286  
         *neighbors*, 289-292  
         *overview*, 279-280

- EtherChannel, 56
  - channel-group command options, 57-58*
  - interface configuration settings, 58-59*
- Frame Relay, 369
  - end-to-end encapsulation, 378*
  - Layer 1 issues on access links, 370*
  - Layer 2 issues on access links, 371*
  - mapping issues, 377-378*
  - mismatched subnet numbers, 379*
  - PVC (permanent virtual circuit) problems, 372-377*
  - self-assessment, 381-382*
  - suggested process, 369-370*
- IPv4 routing, 110, 132-133
  - ACLs (access control lists), 151-152*
  - DHCP Relay issues, 140-141*
  - DNS problems, 136-137*
  - IP address settings, 137*
  - IP forwarding, 143-146*
  - LAN issues, 141-142*
  - mismatched IPv4 settings, 133-134*
  - mismatched masks, 134-135*
  - mismatched VLAN trunking configuration, 138-140*
  - normal routing behavior, predicting, 111-115*
  - with ping command, 115-124*
  - router WAN interface status, 150-151*
  - with show ip route command, 144-146*
  - with traceroute command, 124-129*
  - VLSM, 146-150*
- IPv6 routing, 421
  - DNS issues, 424*
  - ping failures, 421-423*
  - SLAAC issues, 425-426*
  - stateful DHCP, 424-425*
  - traceroute failures, 427-429*
- LAN switching, 64-65
  - analyzing/predicting normal operation, 65-68*
  - ARP Reply (unicast), forwarding path of, 98-101*
  - ARP requests (broadcast), forwarding path of, 95-98*
  - cabling pinouts, 75*
  - control plane analysis, 67-68*
  - data plane analysis, 66-67*
  - duplex issues, 77-78*
  - exam tips, 70*
  - example of, 91*
  - forwarding process overview, 11-12, 71-72*
  - interface status codes, 74*
  - isolate filtering/port security problems, 79-82, 90-91*
  - isolation of interface problems, 73-78, 88-90*
  - isolation of VLAN/trunking problems, 15, 82-86, 92-94*
  - network diagram confirmation via CDP, 72-73, 87-88*
  - notconnect state, 75*
  - problem isolation, 68-69*
  - root cause analysis, 69-70*
  - switch interface speed and duplex, 76-77*
  - switch interface speeds, 77-78*
- OSPFv2 (Open Shortest Path First version 2)
  - area mismatches, 294*
  - duplicate router IDs, 295-296*
  - Hello/dead timer mismatches, 296-297*
  - interfaces, 280-281, 286-288*
  - mismatched MTU settings, 299*
  - mismatched network types, 297-299*
  - neighbors, 289-297*
  - overview, 279-280*
- OSPFv3 (Open Shortest Path First version 3)
  - interfaces, 443-444*
  - IPv6 routes, 453-454*
  - LSAs (link-state advertisements), 450-451*
  - neighbors, 446-448*
- serial links
  - keepalive failure, 327*
  - layer 1 problems, 325-326*

*layer 2 problems*, 326  
*layer 3 problems*, 329-330  
 PAP/CHAP authentication failure,  
 328-329

STP (Spanning Tree Protocol), 51  
*convergence*, 56  
*DPs (designated ports)*, 54-56  
*EtherChannel*, 56-59  
*root switches*, 51-52  
*RPs (root ports)*, 52-54

VLSM, 146  
*overlapping subnets*, 148-150  
*recognizing when VLSM is used*,  
 147

## trunking

mismatched VLAN trunking configura-  
 tion, 138-140  
 trunking problems, isolating, 15, 82-86,  
 92-94  
 verifying, 15, 93-94

TTL (Time To Live), 125

TTL (Time-to-Live) Exceeded, 125

tunnel destination command, 186, 192

tunnel interfaces, 182-184

tunnel mode gre command, 192

tunnel source command, 186, 192

## tunnels

explained, 178  
 GRE (generic routing encapsulation) tun-  
 nels  
*configuring*, 185-187  
*explained*, 181-182  
*over unsecured network*, 183-184  
*routing over*, 182-183  
*tunnel interfaces*, 182-184  
*verifying*, 187-189

VPN tunnels, 177-178

Two-way neighbor state (OSPF neigh-  
 bors), 206

## U

---

uck9, 530

UDI (unique device identifier), 531

undebg all command, 302

unequal-cost load balancing, 268

unicast IPv6 addresses, 411-413

unicasts, forwarding, 99-100

unique device identifier (UDI), 531

## universal images

explained, 528  
 IOS software activation, 529-530  
*Cisco License Manager (CLM)*,  
 530-531  
*manual activation*, 531-536  
*right-to-use licenses*, 536-538

unsecured networks, GRE (generic rout-  
 ing encapsulation) tunnels, 183-184

update messages (EIGRP), 240-241

upgrading images into Flash memory,  
 505-507

username command, 334

## V

---

variance, 268-269

variance command, 253, 268-269, 276,  
 462, 465, 477

## VC (virtual circuits)

CIR (committed information rate), 338  
 explained, 337-340, 345-346

## verifying

EIGRPv4 core features, 255  
*interfaces*, 256-258  
*IPv4 routing table*, 259-260  
*neighbor status*, 258-259  
*neighbors*, 290-291

Frame Relay configurations, 364-365

GLBP (Gateway Load Balancing  
 Protocol), 167-169

GRE (generic routing encapsulation) tun-  
 nels, 187-189

HSRP (Hot Standby Router Protocol),  
 164-167

IOS images, 512-513

IPv6 connectivity

*from hosts*, 417-418

*from routers*, 419-420

LAN switches

*determining VLAN of frames*,  
 13-15

*verifying trunks*, 15

*viewing MAC address table*, 12-13

- NetFlow, 498-499
- OSPFv2 (Open Shortest Path First version 2), 220-223
  - areas*, 221
  - DRs (dedicated routers) and BDRs (backup DRs)*, 221-222
  - LSAs (link-state advertisements)*, 222
  - OSPF routes*, 223
- OSPFv3 (Open Shortest Path First version 3)
  - interfaces*, 443
  - LSAs (link-state advertisements)*, 448-450
  - metrics*, 451-453
  - neighbors*, 445-446
- STP (Spanning Tree Protocol) operation, 40-43
- Syslog (System Message Logging), 494-495
  - trunking and VLAN 3, 93-94
- very small aperture terminal (VSAT)**, 391
- virtual circuits (VC)**
  - explained, 337-340
  - Layer 3 addressing, 345-346
- Virtual Private LAN Service (VPLS)**, 389
- virtual private networks**. *See* VPNs
- Virtual Router Redundancy Protocol (VRRP)**, 160
- VLANs**
  - access interface VLAN assignments, checking, 92
  - active VLANs, checking for, 92-93
  - broadcast forwarding, 97-98
  - determining VLAN of frames, 13-15
  - isolating VLAN and trunking problems, 15, 82-86, 92-94
  - STP (Spanning Tree Protocol) configuration
    - BID (bridge ID)*, 39-40
    - per-VLAN configuration settings*, 38-39
    - per-VLAN costs*, 40
    - system ID extension*, 39-40
  - trunking
    - mismatched VLAN trunking configuration*, 138-140
    - verifying*, 93-94
- VLSM, troubleshooting**, 146
  - overlapping subnets, 148-150
  - recognizing when VLSM is used, 147
- VPLS (Virtual Private LAN Service)**, 389
- VPNs (virtual private networks)**
  - ASA (Adaptive Security Appliances), 179
  - clients, 179
  - explained, 176
  - extranet VPNs, 178
  - GRE (generic routing encapsulation) tunnels
    - configuring*, 185-187
    - explained*, 181-182
    - over unsecured network*, 183-184
    - routing over*, 182-183
    - tunnel interfaces*, 182-184
    - verifying*, 187-189
  - intranet VPNs, 178
  - IPsec VPNs, 179-180
  - remote-access VPNs, 178
  - routers, 179
  - scalability, 179
  - security, 177
  - self-assessment, 190-191
  - site-to-site VPNs, 177
  - SSL VPNs, 181
  - tunnels, 177
  - VPN tunnels, 177-178
- VRRP (Virtual Router Redundancy Protocol)**, 160
- VSAT (very small aperture terminal)**, 391

## W-X-Y-Z

---

**WAN interface cards (WICs)**, 313

**WANs (wide area networks)**

Frame Relay. *See* Frame Relay

HDLC (High-level Data Link Control)

*building WAN links*, 315-316

CSU/DSU, 315

*explained*, 311

*HDLC configuration*, 317-320

*layer 1 leased lines*, 311-316

*layer 2 leased lines*, 316-317

*leased line components*, 312-314

- self-assessment*, 332-333
- T-carrier system*, 314
- neighbors, testing with ping, 122-123
- PPP (Point-to-Point Protocol)
  - authentication*, 322-323
  - CHAP (Challenge Handshake Authentication Protocol)*, 324-329
  - configuring*, 323-324
  - explained*, 320-321
  - framing*, 321
  - LCP (Link Control Protocol)*, 321-323
  - NCP (Network Control Protocols)*, 321
- private WANs
  - Ethernet WANs*, 389-390
  - explained*, 387
  - Frame Relay*, 388
  - leased lines*, 387-388
  - MPLS (Multiprotocol Label Switching)*, 390-391
  - VSAT (very small aperture terminal)*, 391
- public WANs, 392
  - 3G/4G mobile phone access*, 397-398
  - Cable Internet*, 396
  - dial access with modems and ISDN*, 393-394
  - DSL (digital subscriber line)*, 395-396
  - Internet Access Links*, 392
  - PPPoE (PPP over Ethernet)*, 398-400
- router WAN interface status, troubleshooting, 150-151
- self-assessment*, 402
- troubleshooting
  - keepalive failure*, 327
  - layer 1 problems*, 325-326
  - layer 2 problems*, 326
  - layer 3 problems*, 329-330
  - PAP/CHAP authentication failure*, 328-329
- VPNs (virtual private networks)
  - ASA (Adaptive Security Appliances)*, 179
  - clients*, 179
  - explained*, 176
  - extranet VPNs*, 178
  - GRE (generic routing encapsulation) tunnels*, 181-189
  - intranet VPNs*, 178
  - IPsec VPNs*, 179-180
  - remote-access VPNs*, 178
  - routers*, 179
  - scalability*, 179
  - security*, 177
  - self-assessment*, 190-191
  - site-to-site VPNs*, 177
  - SSL VPNs*, 181
  - tunnels*, 177
  - VPN tunnels*, 177-178
- WICs (WAN interface cards), 313
- wildcard masks, configuring EIGRPv4 with, 255
- wireless Internet, 397
- write erase command, 520, 525