



IP COMMUNICATIONS

## Fax, Modem, and Text for IP Telephony

The Definitive Resource for Understanding, Designing,  
Configuring, and Troubleshooting Fax, Modem, and Text  
in Today's IP Networks

# Fax, Modem, and Text for IP Telephony

David Hanes, Gonzalo Salgueiro

Copyright © 2008 Cisco Systems, Inc.

Published by:

Cisco Press

800 East 96th Street

Indianapolis, IN 46240 USA

All rights reserved. No part of this book may be reproduced or transmitted in any form or by any means, electronic or mechanical, including photocopying, recording, or by any information storage and retrieval system, without written permission from the publisher, except for the inclusion of brief quotations in a review.

Printed in the United States of America

First Printing June 2008

Library of Congress Cataloging-in-Publication data is on file.

ISBN-13: 978-1-58705-269-9

ISBN-10: 1-58705-269-5

## Warning and Disclaimer

This book is designed to provide information about fax, modem, and text technologies for IP Telephony. Every effort has been made to make this book as complete and as accurate as possible, but no warranty or fitness is implied.

The information is provided on an “as is” basis. The authors, Cisco Press, and Cisco Systems, Inc. shall have neither liability nor responsibility to any person or entity with respect to any loss or damages arising from the information contained in this book or from the use of the discs or programs that may accompany it.

The opinions expressed in this book belong to the authors and are not necessarily those of Cisco Systems, Inc.

## Trademark Acknowledgments

All terms mentioned in this book that are known to be trademarks or service marks have been appropriately capitalized. Cisco Press or Cisco Systems, Inc., cannot attest to the accuracy of this information. Use of a term in this book should not be regarded as affecting the validity of any trademark or service mark.

## Corporate and Government Sales

The publisher offers excellent discounts on this book when ordered in quantity for bulk purchases or special sales, which may include electronic versions and/or custom covers and content particular to your business, training goals, marketing focus, and branding interests. For more information, please contact: **U.S. Corporate and Government Sales** 1-800-382-3419 [corpsales@pearsontechgroup.com](mailto:corpsales@pearsontechgroup.com)

For sales outside the United States please contact: **International Sales** [international@pearsoned.com](mailto:international@pearsoned.com)

---

## Command Syntax Conventions

The conventions used to present command syntax in this book are the same conventions used in the IOS Command Reference. The Command Reference describes these conventions as follows:

- **Boldface** indicates commands and keywords that are entered literally as shown. In actual configuration examples and output (not general command syntax), boldface indicates commands that are manually input by the user (such as a **show** command).
- *Italic* indicates arguments for which you supply actual values.
- Vertical bars (|) separate alternative, mutually exclusive elements.
- Square brackets ( [ ] ) indicate an optional element.
- Braces ( { } ) indicate a required choice.
- Braces within brackets ( [ { } ] ) indicate a required choice within an optional element.

## Introduction

The advent of VoIP has led to revolutionary changes in the world of telecommunications. Information that was transported on traditional telephony infrastructures such as voice, video, and modulated data is transitioning to IP backbones. However, in this transition process, modulated data such as fax, modem, and text is often overlooked. Fax, modem, and text are treated like regular voice communications in many cases when in fact they have different transport requirements and usually need unique transport protocols for communication to be reliable.

We, the authors of this book, have about 25 years of combined networking experience with the majority of it focusing on faxes, modems, and VoIP. We have seen and experienced firsthand as Cisco TAC engineers the problems that are encountered with fax and modem communications. While one of the most common problems we encounter is the failure to take into account the unique transport requirements of fax, modem, and text, we also have seen problems with the configuration of the multitude of fax-, modem-, and text-related commands in Cisco voice gateways. In addition, we have realized that many times there is just a lack in understanding of basic passthrough and relay fundamentals as they are implemented on Cisco voice products. Addressing these problems and how to troubleshoot them were our main focus while writing this book.

Therefore, you will notice that this book includes a comprehensive design guide for getting fax, modem, and text deployments working successfully from the start, a commonsense configuration section, and a thorough troubleshooting guide. Equally as important, we devoted a whole section to the fundamentals of passthrough and relay and how they are implemented on Cisco voice products. In this book, we address all the main difficulties that we have seen with the implementation of fax and modems in IP environments.

We have written this book to be the definitive resource for understanding, designing, configuring, and troubleshooting fax, modem, and text in today's IP networks. Whether you are a network designer, voice engineer, or simply someone who must support fax, modem, and text communications over IP networks, this book is practically a necessity. If you understand basic VoIP, this book will just build upon that core knowledge.

Many books and other resources are available that discuss VoIP, and some even have a casual mention of transporting fax or modem communications. However, this book is the only one that provides a comprehensive, one-stop reference for addressing all aspects of fax, modem, and text communication.

## **Target Release: Cisco IOS Software Version 12.4(9)T1**

The examples and features explained throughout this book for Cisco IOS voice gateways target Cisco IOS Software Release 12.4(9)T1. However, other IOS versions should be applicable to the majority of this book, too. Be aware, however, that features and implementations might differ somewhat in other IOS versions. Other software versions for devices such as Cisco Unified Communications Manager, 6608, and the VG248 are noted in the text when applicable.

## **Goals and Methods**

This book is designed to be the only resource you will ever need for handling fax, modem, and text communications in IP telephony environments. From basic theory to design solutions to configuration to troubleshooting, all aspects are covered in a clear, concise manner.

## **Who Should Read This Book?**

Just about every IP telephony (IPT) installation has at least one fax machine, and larger installations often include modems and text telephony devices, too. If you work with IPT, your job has already required or more than likely will require in the future that you handle fax, modem, and text communications in your network. For this reason, this book is an indispensable resource that should reside beside your other books dealing with IPT.

In some areas, this book expects you to have basic IPT knowledge. You should be familiar with the Internet Protocol, possess a good grasp of voice fundamentals, and be familiar with at least one of the various call control protocols. If you work with IPT on a consistent basis, you probably already have this knowledge.

Because of this book's comprehensive coverage of fax, modem, and text, it contains relevant information for a wide variety of readers who work with IPT. For anyone who works in IPT network design, such as design engineers, network architects, or systems engineers, this book features a comprehensive design and planning section. If you deploy and install IPT networks, an easy-to-understand configuration section provides the pertinent commands and sample configurations necessary for successfully transporting fax, modem, and text communications. Lastly, for those who support IPT networks, such as customer support engineers, field engineers, network administrators, and escalation engineers, a detailed troubleshooting section equips you with the knowledge and techniques to handle any issue that arises.

If you work with IPT, you will encounter fax, modem, and text devices if you have not already. These devices have special requirements and protocols that must be addressed for successful IP integration and deployment. When it comes time to handle fax, modem, and text communications as part of your job in IPT, this is the one resource that you want by your side.

---

## How This Book Is Organized

This book is logically laid out with critical, fundamental concepts defined at the beginning in Chapters 1 to 6. Later chapters build upon these concepts to assist you with network design, configuration, and troubleshooting. Once the initial fundamental chapters are covered in the first two sections, the remaining chapters do not have to be read in any particular order even though the listed chapter sequence is what we believe to be the most beneficial for learning the subject matter.

The chapters in this book are divided into the following sections and cover the following topics:

- **Part I Laying the Groundwork**

Provides the fundamentals of how faxes, modems, and text telephony devices work.

- **Chapter 1, “How Modems Work”**—Discusses modem architecture, different modem types, and the methods and modulations used by modems for communication. In addition, a basic modem call is analyzed, including the negotiation phases and data mode.
- **Chapter 2, “How Fax Works”**—Covers the core elements of fax technology, including the common group classifications and standards, an in-depth section on fax messaging, and page encoding.
- **Chapter 3, “How Text Telephony Works”**—Provides an introductory look at text telephony and its fundamentals. Basic text telephony operation and concepts are covered along with a technical discussion of the Baudot text telephone protocol.

- **Part II IP Solutions and Design**

Describes the various switchover methods and transport options that are used to handle fax, modem, and text communications. Design chapters then help you determine the best solution for transporting your fax, modem, and text traffic.

- **Chapter 4, “Passthrough”**—Shows you the fundamental methods and principles necessary for using a voice codec for transporting fax, modem, and text. The different passthrough methods on Cisco voice gateways and their various switchovers are also discussed.
- **Chapter 5, “Relay”**—Details the intricacies of relay operation and its various transport methods and switchover types for fax, modem, and text.
- **Chapter 6, “T.37 Store-and-Forward Fax”**—Demonstrates the workings and fundamentals of fax and e-mail integration using onramp and offramp faxing.
- **Chapter 7, “Design Guide for Fax, Modem, and Text”**—Provides pertinent design information and best practices for integrating fax, modem, and text telephony into your IP network.
- **Chapter 8, “Fax Servers”**—Concentrates on the design and planning aspects of integrating fax servers into your network. In addition to fax server benefits and integration models, fax server-specific configuration and troubleshooting information is also provided.

- **Part III Configuration**

Details the configuration tasks for a variety of Cisco products that are essential for transporting fax, modem, and text successfully.

- **Chapter 9, “Configuring Passthrough”**—Provides the configuration commands for enabling passthrough and its various features on Cisco products.
- **Chapter 10, “Configuring Relay”**—Illustrates the numerous commands for successfully configuring the different relay transport methods and features on Cisco products. Also included are IOS voice gateways sample configurations of common deployment scenarios.
- **Chapter 11, “Configuring T.37 Store-and-Forward Fax”**—Breaks down the somewhat confusing T.37 store-and-forward fax configuration process for onramp and offramp into simplified steps. Within each configuration step, the applicable commands are shown.

- **Part IV Troubleshooting**

Discusses the troubleshooting techniques and procedures used by Cisco TAC engineers for resolving fax, modem, and text issues.

- **Chapter 12, “Troubleshooting Passthrough and Relay”**—Details a fax, modem, and text troubleshooting methodology that efficiently resolves passthrough and relay problems. Each step of this troubleshooting methodology correlates directly to a section within the chapter that shows you the key commands, debugs, and troubleshooting steps to execute for rapidly resolving issues from the most basic to the complex.
- **Chapter 13, “Troubleshooting T.37 Store-and-Forward Fax”**—Highlights graphical troubleshooting models for onramp and offramp faxing that allow you to zero in on problems quickly. In-depth debugging techniques and procedures for the different processes within the graphical model are also provided.

## Comments for the Authors

The authors are interested in your comments and suggestions about this book. Please send feedback to the following e-mail address:

faxmodemtextbook@external.cisco.com

## Further Reading

The authors recommend the following resources for more information.

### Cisco.com

The Cisco website is one of the best resources for additional documents related to fax, modem, and text technologies and IP telephony in general. Usually the easiest way to find a document is to use the web page's search feature. Other useful links on Cisco.com include the following:

- For design related documents, see <http://www.cisco.com/go/srnd>.
- For Unified Communications product information, refer to <http://www.cisco.com/go/unified>.
- For a listing of support information links, including command references, design and troubleshooting documents, and configuration guides, go to <http://www.cisco.com/go/support>.

The following technical books are also recommended for supplementing the information in this book and for increasing your overall IP telephony knowledge. These books can be examined at a local technical bookseller or by entering the title in the search box at <http://www.ciscopress.com>.

### *Voice over IP Fundamentals, Second Edition*

The book *Voice over IP Fundamentals* (ISBN 1-58705-257-1) is a good place to start for those making a move into the IP telephony world, and it is also a handy reference for those already familiar with VoIP.

### *Troubleshooting Cisco IP Telephony*

You can find comprehensive troubleshooting information for all the major components of a Unified Communications network in the book *Troubleshooting Cisco IP Telephony* (ISBN 1-58705-075-7).

# Design Guide for Fax, Modem, and Text

---

In the design and planning stage of many VoIP networks, accounting for modulated communications, such as faxes, modems, and text telephony devices is often omitted or forgotten. Unfortunately, because of some of the unique characteristics of transporting modulated communications over IP and certain gateway and protocol interoperability issues, this can lead to problems later during network implementation.

This chapter provides the design and planning information necessary to ensure that a proposed VoIP network solution will also properly handle the transportation of fax, modem, and text communications. Specifically, the following sections are covered:

- **General Passthrough and Relay Design Considerations:** Addresses basic design considerations that are applicable to the variety of transport methods based on passthrough and relay
- **Fax Design Considerations:** Covers design attributes that are only pertinent to transporting fax using Cisco voice gateways
- **Modem Design Considerations:** Discusses the design aspects of integrating modem communications over an IP network
- **Text Design Considerations:** Provides design details on how text telephone transmissions can be effectively transported using text over G.711 and Cisco text relay

The organization of this chapter is such that the first section, “General Passthrough and Relay Design Considerations,” should be read first. Although it might be tempting to skip this first section as you head to specific design information contained later in the chapter, this first section contains foundational information on the passthrough and relay transport methods that is applicable to fax, modem, and text telephony. Therefore, understanding the first section of this chapter is critical in getting the most out of the rest of the chapter.

After the first section has been covered, you may skip directly to the fax, modem, or text design section. Each of these sections builds on the general concepts covered in the first section while providing additional information about the transport methods available for fax, modem, and text telephony.

## General Passthrough and Relay Design Considerations

A number of design considerations must be looked at when designing VoIP networks that will successfully handle modulated communications such as fax, modem, and text. Not taking into account these design considerations from the beginning can cause problems later upon implementation.

This section focuses on passthrough and relay design considerations in a general sense, meaning that the information in this section applies equally to faxes, modems, and text devices. These considerations are summarized in Table 7-1. More specific design considerations directly applicable to fax, modem, and text communications are covered in subsequent sections of this chapter.

**Table 7-1** *General Passthrough and Relay Design Considerations Summary*

Design Consideration	Explanation
Bandwidth	Utilizing much less bandwidth per call is one of the main benefits of relay. Passthrough relies on the G.711 voice codec for transport, and this uncompressed codec comparably consumes much more bandwidth.
Call control protocol	Not all call control protocols support all the various passthrough and relay transport methods. Therefore, it is important to know the limitations of each call control protocol from a fax, modem, and text transport perspective.
Quality of service (QoS)	The QoS requirements for modulated communications can be different from what is needed for a typical VoIP call. For example, fax traffic can handle a higher end-to-end delay than a standard VoIP call, but it typically cannot tolerate the same degree of packet loss.
Redundancy	Relay protocols typically offer built-in redundancy options, whereas the redundancy option with passthrough is less robust and not always supported.
Resource utilization	Certain passthrough and relay calls can be resource intensive to the voice gateway as certain thresholds are approached.
Secure Real-Time Transport Protocol (SRTP)	Fax and modem calls can use the secure RTP feature, but only for transport methods that make use of a full RTP header.
Timing and synchronization	Certain clocking dependencies exist that can affect fax, modem, and text calls. This is especially true when a form of the passthrough transport method is implemented as digital signal processor (DSP) playout buffers may eventually slip on calls of a significantly long duration.

Each design consideration in Table 7-1 is discussed in more detail in the following subsections. In addition, as you read each subsection, you will notice differences between passthrough and relay. Design considerations for one transport method are not always applicable to the other. If you are trying to decide whether passthrough or relay should be used for a particular network design, these subsections provide some valuable information.

## Bandwidth

Bandwidth consumption of passthrough and relay calls is one of the most overlooked aspects of VoIP network design, and it can have a major impact on network capacity planning. Often, the VoIP network is designed with only traditional VoIP calls in mind. Modulated traffic such as faxes is often overlooked completely or the improper assumption is made that modulated communications and voice traffic can be accounted for in the same manner.

All passthrough and relay calls start out as voice calls using the user-defined codec. For this reason, it is important to know how much bandwidth a call is consuming before it switches over to passthrough or relay. Although bandwidth concerns might not be as critical in LAN environments, this is not usually the case in WANs.

Table 7-2 highlights the bandwidth consumed by some common voice codecs when being transported via the WAN protocol, Frame Relay. Even though Table 7-2 might not apply to your specific voice network, it is still essential to understand how much bandwidth your voice calls consume. If any of your voice calls transition to passthrough or relay, the bandwidth utilized per call can drastically change, which can impact bandwidth provisioning over a lower-speed link.

**Table 7-2** *Bandwidth Consumption for a VoIP Call over Frame Relay*

Codec (bit rate)	Packetization Interval (ms)	Voice Payload (bytes)	Packets per Second	Bandwidth per Call (Kbps)
G.711 (64 Kbps)	20	160	50.0	82.8
G.711 (64 Kbps)	30	240	33.3	76.5
G.729 (8 Kbps)	20	20	50.0	26.8
G.729 (8 Kbps)	30	30	33.3	20.5
G.723 (6.3 Kbps)	30	24	33.3	18.9

The bandwidth calculations for each codec in Table 7-2 assume IP, UDP, and RTP header overhead to be 40 bytes and for the Frame Relay overhead to be 7 bytes (including a flag byte). However, assuming a constant header overhead, you can see how increasing the

packetization interval includes more 10 ms DSP samples per packet and this in turn decreases the bandwidth used per call. For example, if G.711 uses the default 20 ms packetization interval, each call uses 82.8 Kbps of bandwidth. However, changing to a 30 ms packetization interval on the voice gateways lowers the bandwidth to 76.5 Kbps. Note that the initial sample value for each codec in Table 7-2 is the default on the Cisco voice gateways.

---

**TIP**

Cisco.com has a useful tool known as the Voice Codec Bandwidth Calculator that is available to registered Cisco.com users. This tool allows you to select from a number of different codecs, Layer 2 protocols, and other parameters, and it then calculates the amount of bandwidth consumed for the selected number of VoIP calls. You can find the Voice Codec Bandwidth Calculator at <http://tools.cisco.com/Support/VBC/do/CodecCalc1.do>.

---

Because passthrough always forces the use of the high-bandwidth G.711 codec, you can see how this can be a problem if only G.729 voice calls are planned across the WAN. A single fax passthrough call at 82.8 Kbps consumes more bandwidth than three G.729 calls at 26.8 Kbps each. If you plan on transporting fax, modem, or text telephony traffic using a passthrough transport mechanism such as modem passthrough, fax pass-through, or text over G.711, ensure that the proper amount of bandwidth is taken into account.

The calculations in Table 7-2 do not take into consideration the use of bandwidth reduction mechanisms such as Voice Activity Detection (VAD) and the Compressed Real-Time Transport Protocol (CRTP). VAD can dramatically reduce voice bandwidth by not transmitting voice packets when silence is occurring. Unfortunately, VAD causes problems during passthrough (because of signal clipping) and therefore it cannot be used when G.711 is transporting modulated data. In the cases of modem passthrough and fax pass-through, VAD is automatically disabled as part of the switchover.

If CRTP is used, the amount of bandwidth consumed per call can be reduced at the expense of CPU cycles on the voice gateway. For example, CRTP enabled for a standard G.711 call drops the bandwidth over Frame Relay from 82.8 Kbps to 67.6 Kbps. Although CRTP is effective at reducing bandwidth for voice, passthrough, and even Cisco fax relay calls, caution should be exercised if CRTP is to be enabled for large numbers of calls on a single voice gateway.

Although VAD and CRTP typically lower bandwidth requirements, redundancy is an option for some passthrough and relay transport methods and has the opposite effect. Redundancy increases the bandwidth consumed per call but provides the benefit of more reliable communications in networks where packet loss, jitter, and other impairments are present. The effect of redundancy on the amount of bandwidth consumed for passthrough and relay calls is covered in the section “Redundancy” later in this chapter.

Bandwidth calculations for passthrough-based calls are quite simple because passthrough always uses the G.711 codec. On the other hand, bandwidth calculations for relay calls can be a bit more complicated. Certain assumptions and worst-case scenarios have to be made to arrive at a bandwidth consumption value that will prevent oversubscription. However, despite this additional complication of calculating relay bandwidth consumption, a large reduction in the bandwidth consumed per call is gained when using a relay transport method compared to passthrough.

The consumption of less bandwidth is one of the major benefits of relay over passthrough, and it occurs because relay demodulates the incoming data. Therefore, only the necessary information is transported across IP, meaning that a 9600 bps fax call will only occupy 9600 bps plus the additional header overhead. Passthrough, on the other hand, does not make a discrimination of what is the actual modulated data, and it samples everything, consuming much larger amounts of bandwidth.

The reason that bandwidth calculations for relay are a bit more complicated has to do with the asymmetrical nature of most modulated communications to begin with. For example, during a fax call, a page is sent by the originating fax machine to the terminating fax machine. The bandwidth consumed during this page transmission will be at a maximum in one direction but zero in the other direction because a fax communication is half duplex. In addition, all the fax T.30 signaling messages occur at 300 bps, significantly slower than page transmission speeds. Therefore, bandwidth measurements for fax relay calls usually look at the maximum page transmission speed allowed for the call. However, you should realize that this peak bandwidth is not seen for the whole fax call, and when it does occur, it occurs in only one direction. Figure 7-1 highlights the varying and asymmetrical bandwidths for a T.38 fax relay call. Cisco fax relay is similar in nature.

The T.38 low-speed bandwidth of 8 Kbps and high-speed bandwidth of 25 Kbps as shown in Figure 7-1 are commonly used values in capacity planning for T.38 fax over Frame Relay or over Ethernet. In actuality, because the Frame Relay header is a few bytes smaller than Ethernet, using a Frame Relay encapsulation with T.38 saves a few additional kilobits of bandwidth. However, for the sake of making a network design estimate, the 25 Kbps value is widely used for both Ethernet and Frame Relay bandwidth calculations. This value assumes that the T.38 fax call has negotiated at its maximum speed of 14.4 Kbps.

As touched on previously, fax relay calls use less bandwidth if the fax endpoints negotiate a rate lower than 14400 bps. For example, a 7200 bps T.38 fax relay call consumes only about 18 Kbps of bandwidth compared to the 25 Kbps needed for a 14.4 Kbps fax call. However, unless you force all the fax calls to this lower rate using the **fax rate** command, you must budget for the maximum speed of 14.4 Kbps. More information on the **fax rate** command and how you can use it to restrict the page transfer speed and consequently the fax relay bandwidth can be found in Table 10-3 in Chapter 10, “Configuring Relay,” as well as the section “Fax Relay Data Rate” in Chapter 12, “Troubleshooting Passthrough and Relay.”

**Figure 7-1** Low- and High-Speed Bandwidths for a T.38 Fax Relay Call

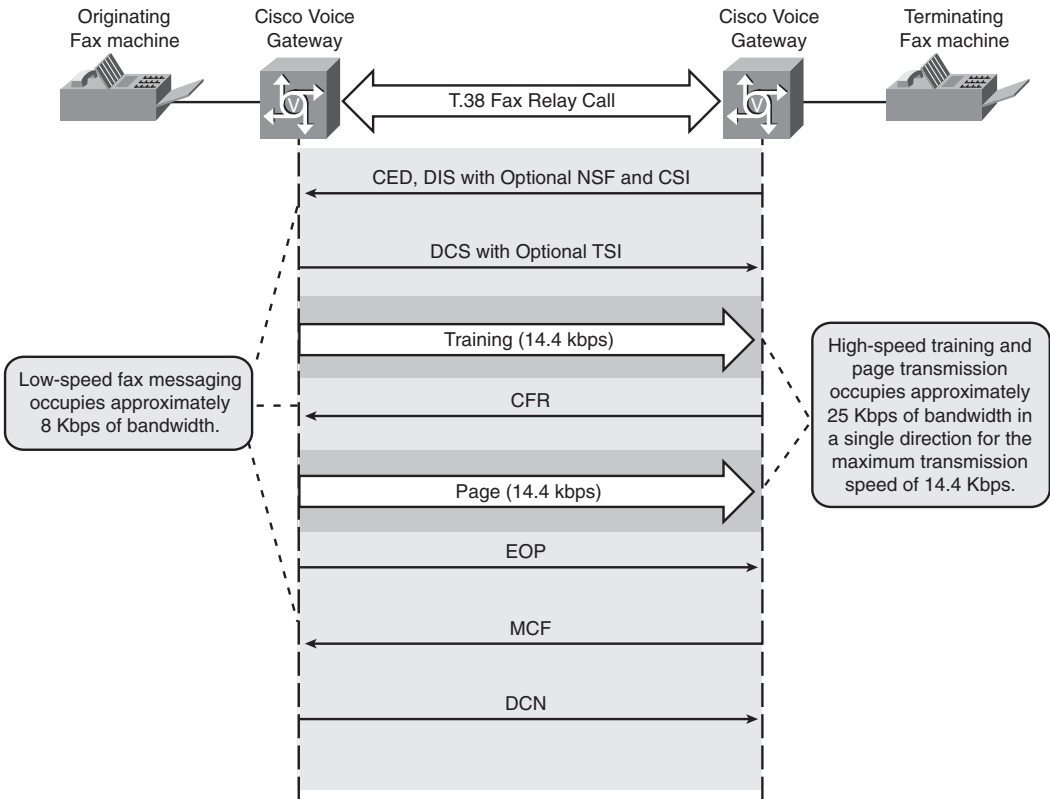

When planning for large numbers of fax relay calls, less bandwidth than the peak numbers discussed here will be seen for the aggregate number of calls. This occurs because all the faxes probably do not negotiate to the maximum 14.4 Kbps speed, and at any give moment not all the calls are consuming the maximum bandwidth with a page transmission. Recall that when pages are not being sent, a T.38 fax relay call needs only approximately 8 Kbps of bandwidth.

Although G3 fax calls are half duplex, modem calls are usually full duplex. However, modems rarely send and receive the maximum amount of data concurrently. For this reason, peak modem relay bandwidth is not used for planning bandwidth utilization by a modem. In fact, it is typically considered heavy modem usage when data is being sent and received more than 25 percent of the time. Therefore, an allotment of about 45 Kbps is generally allocated to each modem relay call. Table 7-3 highlights the peak bandwidth consumed by T.38 and Cisco fax relay and the average bandwidth for modem relay.

**Table 7-3** *Fax and Modem Relay Bandwidth Consumption*

Relay Type	Bandwidth per Call (Approximate)
T.38 fax relay (fax speed of 14.4 Kbps over Frame Relay, T.38 redundancy disabled)	25 Kbps
Cisco fax relay (Fax Speed of 14.4 Kbps Over Frame Relay with default 20 byte payload)	48 Kbps
Cisco modem relay (V.34 modulation at a speed of 33.6 Kbps)	45 Kbps

In Table 7-3, the bandwidth for Cisco fax relay appears high because it uses a small 20 byte payload by default. However, the **fax rate** command has a **bytes** option that allows you to increase the payload size. Using the **fax rate** command to change the payload size from 20 to 40 bytes changes the Cisco fax relay bandwidth to a more manageable 32 Kbps per call.

**TIP**

The bandwidth consumed by Cisco text relay is negligible, so it has not been discussed in this section. Like fax and modem relay, the bandwidth consumed is asymmetric because only one person types at a time. Fast typists may add an additional 3 Kbps of bandwidth to an existing voice call in one direction when full redundancy is enabled. In reality, the bandwidth typically used is much less than that. If only text traffic will be passed over a connection, enabling VAD for the voice call should stop all voice packets. Then, only a couple kilobits of periodic text traffic in each direction will be all the bandwidth that is consumed.

To proactively manage call bandwidths within a VoIP network, various call admission control (CAC) methods can be used. By tracking the number of calls across a link or destined to a particular location or zone, CAC ensures that network paths do not become oversubscribed. Common CAC methods include Resource Reservation Protocol (RSVP), an H.323 gatekeeper, or Cisco Unified Communications Manager (Unified CM) location-based CAC. Consult a comprehensive VoIP resource for additional information about these CAC methods or search for them at Cisco.com.

In addition to CAC specifying bandwidth allocations for voice calls, fax and modem calls will usually have pre-assigned bandwidth allocation or adjustment values. With RSVP, a transition to T.38 fax relay causes an RSVP bandwidth adjustment to 80 Kbps, whereas transitions to modem passthrough, fax pass-through, or modem relay cause a bandwidth adjustment to 96 Kbps. If this bandwidth is unavailable, the call proceeds as best effort without RSVP.

An H.323 gatekeeper uses the same bandwidth adjustment values as RSVP. However, if bandwidth is unavailable, the transition does not occur, and the call proceeds using the original voice codec. Be aware that attempting to transport fax or modem calls using most voice codecs results in a call failure.

Unified CM can use a gatekeeper or locations-based CAC managing calls. However, Unified CM does not make any bandwidth adjustments after a voice call transitions to a fax or modem call. Whatever bandwidth has been allocated for the original voice codec from a CAC perspective will continue to be associated with the fax or modem call, too.

Implementing relay for fax, modem, or text will always save you bandwidth compared to a comparable passthrough call. In many network designs, especially those involving fax or modem traffic over a WAN, bandwidth is the overriding concern. If this is the case, a relay option will always be considered the best practice.

## Call Control Protocol

The call control protocols used when transporting fax, modem, and text with Cisco voice gateways in IP networks are H.323, Session Initiation Protocol (SIP), Media Gateway Control Protocol (MGCP), and Skinny Client Control Protocol (SCCP). However, not all of these call control or voice signaling protocols support all the various passthrough and relay transport methods. Table 7-4 provides a quick overview of the transport methods supported by the H.323, SIP, MGCP, and SCCP voice signaling protocols for Cisco IOS voice gateways.

**Table 7-4** *IOS Gateway Passthrough and Relay Support for H.323, SIP, MGCP, and SCCP Call Control Protocols*

Transport Method	H.323	SIP	MGCP	SCCP
Cisco Fax Relay	Yes*	Yes*	Yes*	Yes*
NSE-based T.38 Fax Relay	Yes	Yes	Yes	Yes
Protocol-based T.38 Fax Relay	Yes	Yes	Yes**	No
Fax pass-through	Yes	Yes	No	No
Modem passthrough	Yes	Yes	Yes	Yes
Cisco modem relay	Yes	Yes	Yes	Yes
Secure modem relay	No	No	Yes	Yes
Cisco text relay	Yes	Yes	Yes	Yes
Text over G.711	Yes	Yes	Yes	Yes

\* IOS platforms such as the 5350, 5400, and 5850 using the NextPort DSP cards do not support Cisco fax relay or the SCCP voice signaling protocol.

\*\* A call agent, such as Unified CM, must also support protocol-based T.38 fax relay.

The information in Table 7-4 shows that H.323 and SIP are the two call control protocols that provide you with the most options for transporting fax, modem, and text calls. The only exception to this is in the case of secure modem relay, which is supported only by MGCP and SCCP. However, secure modem relay is a niche application that is not widely implemented. You can find more information on secure modem relay in the section “Secure Modem Relay” later in this chapter.

The drawbacks of MGCP are the lack of support for fax pass-through and the requirement for a compatible call agent (CA) with protocol-based T.38 fax relay. Currently, only certain versions of Unified CM possess full interoperability with an IOS voice gateway configured for protocol-based T.38 and MGCP. See the section “Unified CM Integration” later in this chapter for more information about Unified CM support of T.38 fax relay.

The SCCP call control protocol lacks support for any transport method that uses a protocol-based switchover. Therefore, SCCP does not support fax pass-through or protocol-based T.38 fax relay. The transport methods in Table 7-4 that use alternative switchover methods, such as Named Signaling Events (NSE), are compatible with SCCP.

Of course, many other factors exist when choosing a call control protocol for a VoIP network, and fax, modem, and text support is typically not the major, deciding factor. However, if fax, modem, and text support is taken into consideration when selecting a voice signaling protocol, H.323 and SIP provide more options and flexibility as compared to MGCP or SCCP.

## QoS

QoS is the measure of transmission quality and service availability for a network. A sufficient level of QoS must be ensured for the real-time traffic of fax, modem, and text; otherwise, these communications will not be reliable.

The transmission quality aspect of QoS is determined by the impairment factors of packet loss, delay, and jitter. Table 7-5 defines these factors while also commenting on how they impact fax, modem, and text traffic compared to VoIP.

As discussed in Table 7-5, a critical difference between fax, modem, and text traffic compared with VoIP traffic is its tolerance for packet loss. Packet loss causes sections of data to be lost in the fax, modem, or text communication. The bits that make up this lost data cannot be reconstructed by the voice gateway using VoIP mechanisms such as interpolation, prediction, or filling with silence.

This is the reason that extensive redundancy mechanisms are available for passthrough and relay. If fax, modem, and text traffic must reside on network paths with packet loss, it is imperative that a transport method using some form of redundancy or error correction be implemented. Data redundancy and error correction options for fax, modem, and text communications are discussed in more detail in the next section.

**Table 7-5** *Fax, Modem, and Text Traffic Impairment Factors*

<b>Factor</b>	<b>Definition</b>	<b>Comment</b>
Packet Loss	A relative measure of the number of packets that were not received compared to the total number of packets transmitted	Although packet loss during a VoIP call is not recommended, it can be handled most of the time if it is less than 1 percent. Mechanisms exist within the voice gateways and the voice codecs themselves that can predict and interpolate a lost voice sample or the missing voice sample can be filled with silence. In addition, the human ear will generally not be able to detect a few missing voice samples during a conversation. However, for fax, modem, and text communications using either passthrough or relay for transport, packet loss can be devastating. Packet loss should not occur at all for fax, modem, and text calls; but if it is present, a transport method using redundancy should be implemented, as discussed in the next section.
Delay	The finite amount of time it takes a packet to reach the receiving endpoint after being transmitted from the sending endpoint	The recommendation for VoIP is to keep the one-way latency (mouth-to-ear) to less than 150 ms. For modem calls, this value is also especially applicable because high-speed modems are more sensitive to delay than fax or text devices. Delay should be minimized as much as possible for modem communications. In the case of fax and text calls using passthrough and relay, delay is not typically as much of an issue as it can be for voice and modems. Fax calls have been known to handle delays of 1 second or more, and the delay limit for text calls is usually defined by the user's patience in waiting for typed responses to appear. Generally, you will always be safe in the handling of delay for fax, modem, and text calls if you stick with the recommended VoIP value of no more than 150 ms.
Jitter	The delay variation between packets or the difference in the end-to-end delay between packets	Average one-way jitter of less than 30 ms is the recommendation to ensure VoIP QoS. This target value applies equally to fax, modem, and text communications, too, especially for passthrough, where the playout buffer is often fixed to a low value and will not dynamically adjust. With fax relay and its fixed 300 ms default playout buffers, keeping the jitter under 30 ms is not quite as critical.

In many networks, loss, delay, and jitter have already been addressed by a QoS solution for VoIP traffic. Fax, modem, and text communications are real-time traffic just like VoIP and are similarly affected by the factors of loss, delay, and jitter to varying degrees. Therefore,

when designing QoS services specifically for fax, modem, and text telephony, it is natural to use the existing VoIP QoS mechanisms that are already in place.

Numerous VoIP QoS mechanisms and tools are currently available for ensuring the integrity of VoIP calls on Cisco voice gateways. For example, you can use Differentiated Services Code Point (DSCP) for the classification and marking of VoIP traffic, along with Low Latency Queuing (LLQ) for the scheduling and queuing of this traffic as it exits the voice gateway. Many other QoS tools are also available, which make the subject of QoS an involved topic that can easily consume another book within itself. Refer to a comprehensive resource on QoS, such as the *Enterprise QoS Solution Reference Network Design Guide*, which is linked off of the following Cisco web page to supplement the QoS information covered in this section:

<http://www.cisco.com/go/srnd/>

As mentioned previously, often fax, modem, and text implementations occur after a VoIP infrastructure and its appropriate QoS policies are already in place and functional. For these cases, just “piggybacking” on the existing VoIP QoS policy is the easiest and most efficient approach.

For example, this piggybacking concept can be easily applied to the classification and marking aspect of QoS for fax, modem, and text traffic. Whatever classification and marking method is currently applied to IP voice traffic in a network should be good enough for fax, modem, and text traffic, too. Having the same classification as a network’s VoIP traffic ensures that the fax, modem, and text traffic will be processed in a prioritized manner by other QoS mechanisms such as LLQ.

Just like with VoIP, fax, modem, and text traffic have a call signaling component and a media component. Each of these must be classified appropriately as part of the QoS policy. As shown in Table 7-6, Cisco makes the following recommendations about marking VoIP call signaling and media packets. Assuming that a network adheres to these recommendations in Table 7-6 for its VoIP traffic, fax, modem, and text traffic should use this same classification scheme, too.

**Table 7-6** *Cisco QoS Classification and Marking Recommendations for VoIP*

Application	Layer 3 Classification		Layer 2 Classification
	IP Precedence (IPP)	Differentiated Services Code Point (DSCP)	Class of Service (CoS)
Call signaling	3	CS3/AF31	3
Voice media	5	EF	5

In Table 7-6, you see that Cisco recommends setting both the IPP and CoS bits to 3 and 5 for the call signaling and voice media, respectively. These settings provide a higher priority to the voice media than the signaling. This same classification scheme is carried on with DSCP, too, where voice media is given a higher priority of EF compared to the call signaling traffic with a value of AF31 or CS3.

The reason for two DSCP values being associated with call signaling has to do with the migration of call signaling from AF31 to CS3 on Cisco voice products. The AF31 setting will eventually be used only for locally defined mission-critical data applications, but in the interim both AF31 and CS3 are valid settings for call signaling traffic.

When viewing Table 7-6, you should understand that “voice media” is applicable to fax, modem, and text traffic and VoIP. You do not need to create a new classification for fax, modem, and text traffic. By marking your fax, modem, and text traffic the same as VoIP, you simplify your overall QoS policy while still providing the proper QoS for these traffic types.

In most cases, this piggybacking solution does not even require additional configuration on your voice gateways. For example, the marking of packets already occurs directly on a voice dial peer. Example 7-1 highlights the default classification for VoIP call signaling and media packets from the IOS command **show dial-peer voice**.

**Example 7-1** *DSCP Values from show dial-peer voice IOS Command*

```
! Output omitted for brevity
  type = voip, session-target = `ipv4:192.168.10.10',
  technology prefix:
  settle-call = disabled
  ip media DSCP = ef, ip signaling DSCP = af31,
  ip video rsvp-none DSCP = af41, ip video rsvp-pass DSCP = af41
  ip video rsvp-fail DSCP = af41,
  UDP checksum = disabled,
! Output omitted for brevity
```

In Example 7-1, you see the highlighted settings of **ip media DSCP = ef** and **ip signaling DSCP = af31**. These DSCP values for the signaling and media traffic matching this dial peer are already correctly set by default. All the packets for VoIP calls matching this dial peer will have the DSCP values set accordingly. In addition, any packets from fax, modem, or text calls matching this dial peer will also be classified the same.

If you desire to change the classification of all traffic matching a particular dial peer, you can do so by using the **ip qos dscp** command. Example 7-2 highlights how this command changes the classification of call signaling packets from the default of AF31 to CS3.

**Example 7-2** *QoS Dial Peer Configuration*

```

!
dial-peer voice 13 voip
 destination-pattern 13..
 session target ipv4:192.168.10.10
 codec g711ulaw
 fax rate 14400
 fax protocol t38 ls-redundancy 0 hs-redundancy 0 fallback cisco
 ip qos dscp cs3 signaling
 no vad
!

```

The dial peer in Example 7-2 uses the IOS command **ip qos dscp cs3 signaling** to set the DSCP classification for all call signaling packets that match this dial peer to CS3. Also notice that this VoIP dial peer is configured to handle voice calls using the G.711 codec, and the command **fax protocol t38** instructs this same dial peer to use T.38 fax relay if V.21 fax flags are detected at any point during the G.711 voice call. Example 7-2 typifies how a T.38 fax relay call can use the QoS classification already in place for a VoIP call.

In some instances, a separate QoS classification is desired for fax, modem, or text traffic. Example 7-2 would not work in this situation, because both the voice and T.38 fax relay traffic use the same dial peer and therefore inherit the same markings. Allowing separate markings adds the complication of managing more QoS classifications, but it can allow greater control and management of fax, modem, and text traffic.

The easiest solution for classifying fax, modem, and text traffic separately from your VoIP traffic is to segment the traffic using specific dial peers. This works especially well if you can isolate the fax, modem, and text traffic to unique dial peers by specific calling or called numbers. When the fax, modem, and text traffic match their own unique dial peers, the commands **ip qos dscp [value] signaling** and **ip qos dscp [value] media** can be configured to classify the packets appropriately.

After the fax, modem, and text traffic has been effectively classified, other QoS tools such as LLQ can act upon these classifications. LLQ can be easily configured to prioritize traffic out an interface based on the DSCP value of the packet. Example 7-3 highlights a basic LLQ configuration for prioritizing packets with a DSCP setting of EF.

**Example 7-3** *Basic LLQ Configuration for Fax, Modem, and Text Traffic*

```

! Output omitted for brevity
!
class-map match-all fax_modem_text_traffic
 match ip dscp ef
class-map match-any call_signaling
 match ip dscp cs3
 match ip dscp af31

```

*continues*

**Example 7-3** Basic LLQ Configuration for Fax, Modem, and Text Traffic (Continued)

```

!
policy-map WAN
  class fax_modem_text_traffic
    priority percent 33
  class call_signaling
    bandwidth percent 5
  class class-default
    fair-queue
!
! Output omitted for brevity
!
interface Multilink1
  description T1 to Branch Office
  ip address 1.1.1.1 255.255.255.252
  service-policy output WAN
  ppp multilink
  ppp multilink group 1
!
! Output omitted for brevity

```

In Example 7-3, two specific class maps are created to address the media and call signaling information for fax, modem, and text calls. The class map for the media is **fax\_modem\_text\_traffic**, and the class map for the call control traffic is **call\_signaling**.

The command **match ip dscp ef** defines the DSCP value that packets must have to be associated with the **fax\_modem\_text\_traffic** map class. For packets to be associated with the **call\_signaling** map class, a DSCP value of either **cs3** or **af31** must be present.

**TIP**

Be careful when implementing an LLQ configuration that does not take advantage of DSCP. For example, it is common for LLQ to be configured to simply prioritize all RTP traffic. This works fine for voice, passthrough, and Cisco fax relay traffic, but it does not work for T.38 fax relay or modem relay, which do not contain an RTP header. Marking traffic with appropriate DSCP values and then prioritizing the real-time DSCP traffic through a queuing strategy such as LLQ is the recommended method for handling QoS for faxes and modems.

The **policy-map WAN** is how LLQ prioritizes and allocates bandwidth for the specific traffic classes defined by the class map configuration. In the case of Example 7-3, the **fax\_modem\_text\_traffic** class under **policy-map WAN** is configured for a priority percentage of 33 by the command **priority percent 33**. This means that up to 33 percent of the total bandwidth for the interface where this LLQ configuration is applied will always be

available for traffic matching the **fax\_modem\_text\_traffic** class map. In addition, this traffic is queued in a priority fashion, where traffic that is not part of the **fax\_modem\_text\_traffic** class may be held back to allow this prioritized traffic to be transmitted first.

For the **call\_signaling** class under the **policy-map WAN** in Example 7-3, the command **bandwidth percent 5** is present. This command reserves 5 percent of the bandwidth for traffic that matches the **call\_signaling** class in the event of interface congestion. With 5 percent of the bandwidth guaranteed for signaling traffic, the proper setup and teardown of fax, modem, and text calls is ensured, even during periods of contention for interface bandwidth.

Assigning an LLQ configuration to an interface is the last step when implementing LLQ. In Example 7-3, the command **service-policy output WAN** applies the LLQ configuration identified by the command **policy-map WAN** to the gateway's interface, **interface Multilink1**.

Although the DSCP classification and marking system along with LLQ queuing are two of the most common QoS tools, you should realize that many additional QoS tools are available, too. Ultimately, it does not matter exactly what QoS mechanisms you use as long as the factors of packet loss, delay, and jitter are controlled as discussed in Table 7-5. In many networks, these factors have already been addressed from a VoIP perspective, and in these cases it is perfectly acceptable to piggyback or use these same VoIP QoS settings for fax, modem, and text traffic, too.

## Redundancy

In the context of passthrough and relay, redundancy is the concept of sending multiple copies of the same data segment. The reasoning behind the redundancy concept is that if a packet is lost or significantly delayed another packet carrying the same information will still arrive at the destination in a timely manner. This ensures that the integrity of the data connection remains intact even though packet loss or significant delay is occurring.

Passthrough calls are notorious for being very sensitive to packet loss, especially when carrying high-speed modem modulations such as V.34 and V.90. Lab testing shows that as little as 0.02 percent packet loss can cause passthrough calls to fail. If redundancy for passthrough is activated, calls can be sustained with up to 1 percent of random packet loss.

Relay transport methods may use improved redundancy or error correction mechanisms that allow them to handle substantially more packet loss than passthrough. In the case of T.38 fax relay and Cisco modem relay, calls can succeed with up to 10 percent random packet loss.

Multiple redundancy methods exist for passthrough and relay depending on the exact transport method selected. Table 7-7 summarizes these redundancy methods by the transport method used.

**Table 7-7** *Passthrough and Relay Redundancy Methods*

<b>Transport Method</b>	<b>Redundancy/Error Correction Support</b>	<b>Comments</b>
Passthrough	One level of redundancy that allows a single repetition of packets based on RFC 2198.	This redundancy method is supported for both faxes and modems using NSE-based passthrough and configured with the <b>modem passthrough</b> configuration command. Redundancy is not supported for protocol-based fax pass-through configurations.
T.38 fax relay	Five levels of redundancy are supported for low-speed messages, and two levels are supported for high-speed messaging.	Multiple layers of redundancy are built in to the T.38 fax relay protocol, making T.38 fax relay the best choice for sending faxes over IP networks that contain high jitter and packet loss.
Cisco fax relay	None.	Cisco fax relay should be used only in VoIP networks free of packet loss.
Cisco modem relay	Error correction.	Instead of redundancy, Cisco modem relay uses an error correction mechanism that efficiently handles packet loss in most situations.
Cisco text relay	3 levels of redundancy.	Redundancy cannot be disabled. At least 1 level of redundancy is always enabled, and the default setting is 2 levels.
Text over G.711	None.	Unable to turn on redundancy for a G.711 voice call.

If you are planning on implementing fax, modem, or text communications over an IP network with impairments and other problems, you should choose a passthrough or relay transport method in Table 7-7 where redundancy is an option. For example, T.38 with its various levels of redundancy should be chosen over Cisco fax relay.

**TIP**

The Cisco implementation of T.38 fax relay transmits the low-speed T.30 messages a single byte at a time, as discussed previously in the section “T.38 Fax Relay” in Chapter 5, “Relay.” Therefore, because of the greater number of packets that must be sent with just a single byte of data compared with bundling multiple bytes per T.38 packet, a greater opportunity exists for packet loss to affect the transmission of low-speed T.30 data. Always configuring at least one level of T.38 fax relay low-speed redundancy on Cisco voice gateways is highly recommended.

When implementing a passthrough redundancy solution, first make sure that the Cisco products being used all have redundancy support. Products such as the VG248 and ATA do not support modem passthrough redundancy and should not be used with other Cisco products that have this option enabled.

A major consideration to take into account when any sort of redundancy is enabled for a passthrough or call relay is bandwidth consumption. If you recall, the bandwidth consumption values displayed previously in Tables 7-2 and 7-3 did not take into account redundancy being enabled.

When redundancy is enabled, the bandwidth can increase significantly. In the case of passthrough, it will more than double because of the extra overhead necessary to identify the redundant data from the primary data within the packet payload. Table 7-8 shows the effects of redundancy on bandwidth for some passthrough and relay transport methods.

**Table 7-8** *Bandwidth Consumptions over Frame Relay for Various Redundancy Levels*

<b>Passthrough/Relay Transport Method</b>	<b>Bandwidth per Call (Approximate)</b>
Passthrough G.711 with no redundancy	83 Kbps
Passthrough G.711 with 2198 single-layer redundancy	170 Kbps
T.38 Fax Relay with high-speed redundancy set to 0	25 Kbps
T.38 Fax Relay with high-speed redundancy set to 1	41 Kbps
T.38 Fax Relay with high-speed redundancy set to 2	57 Kbps

In Table 7-8, you can see that the bandwidth for passthrough more than doubles when redundancy is enabled to a value of 170 Kbps per call. As mentioned previously, this extra bandwidth for redundancy does raise passthrough tolerance to random packet loss to around 1 percent. However, compared to T.38 fax relay or modem relay with its much lower bandwidth consumption and higher tolerance for packet loss, modem passthrough with redundancy appears very inefficient.

The redundancy bandwidth values for Cisco text relay are not included in Table 7-8. The main reason for this is that the bandwidth consumed for Cisco text relay is negligible no matter what the redundancy level is set for. The main determination of bandwidth consumption with Cisco text relay is how fast the person types. Even with redundancy set to its highest value of 3, Cisco text relay should never reach a peak bandwidth greater than 3 Kbps.

The main design consideration for dealing with redundancy is that a tradeoff exists between it and the amount of bandwidth consumed. If an IP network is free of packet loss and high jitter, it is not necessary to enable redundancy when transporting fax, modem, or text communications. However, if packet loss does exist and you want to guarantee a successful call, you must decide how much extra bandwidth needs to be made available for handling redundant data.

## Resource Utilization

Fax, modem, and text calls and their different transport methods may impact the resources of a voice gateway differently. In some cases, this can lead to a need for more DSP resources, and in other cases this can lead to a need for more bandwidth on an interface. Understanding how fax, modem, and text calls can impact the resources on a Cisco voice gateway is an important design concept. Properly planning the resource use of a voice gateway in the beginning can prevent problems later when traffic loads are heavy and resource availability is limited.

Specific design considerations can address the impact that fax, modem, and text calls have on voice gateway resources. Table 7-9 highlights the primary resource utilization design considerations for certain fax, modem, and text transport methods.

**Table 7-9** *Fax and Modem Resource Utilization Considerations*

Transport Method	Resource Affected	Comment
Fax Relay and T.37 store-and-forward fax	DSP	Fax relay and T.37 calls are considered “medium complexity” from a DSP resource perspective, and situations can arise with C5510 DSPs in flex mode where the DSP can become oversubscribed.
Modem relay	DSP	Modem relay calls are considered “high complexity” from a DSP resource perspective, and situations can arise with C5510 DSPs in flex mode where the DSP can become oversubscribed.
Fax relay and T.37 store-and-forward fax	CPU utilization and memory	The processing of fax relay and T.37 calls consume more gateway resources than a voice or passthrough call.

As mentioned in Table 7-9, fax relay, T.37, and modem relay can affect the C5510 DSP when it is in flex mode or flex complexity. The C5510 DSP, the predominant DSP found on Cisco voice gateways today, allows for the oversubscription of DSP resources in flex mode, and this can cause issues without the proper preparation. Table 7-10 shows the primary codecs supported by the C5510, their associated complexity of flex, medium, and high, and the maximum number of calls supported on a DSP for particular complexity mode settings.

As Table 7-10 illustrates, codecs are broken into the codec complexity categories of low, medium, and high. These codec complexity categories group codecs by their DSP resource intensiveness. For example, the low-complexity codecs of G.711, passthrough, and clear channel codec require the least amount of DSP resources.

**Table 7-10** C5510 DSP Utilization for Various Codecs

Codec	Codec Complexity	Maximum Calls Supported on DSP		
		High-Complexity Mode	Medium-Complexity Mode	Flex-Complexity Mode
G.711, passthrough, and clear-channel codec	Low complexity	6	8	16
Fax relay, T.37, G.726, G.729A, and G.729AB	Medium complexity	6	8	8
Modem relay, G.729, G.729B, G.728, G.723, and iLBC	High complexity	6	Not supported	6

The C5510 DSP can also be configured for a complexity mode, which is somewhat different from the codec complexity. The complexity mode defines how the DSP resources are partitioned into channels for handling calls. Each DSP channel can handle a single voice call. For example, if the DSP is configured for a complexity mode of medium, it can only handle calls of medium or low complexity. Table 7-10 illustrates how a C5510 DSP configured for medium-complexity mode can handle up to eight calls of either medium or low codec complexity.

In high-complexity mode, the DSP can handle calls with any codec complexity at the expense of only being able to handle six total calls compared with the eight calls that the DSP can deal with in medium-complexity mode. Configuring medium or high complexity on a C5510 DSP boils down to whether a high-complexity codec is mandatory. For example, if modem relay is to be supported, high-complexity mode must be used; if only medium-complexity or low-complexity codecs are used, however, medium-complexity mode yields more channels per DSP.

**NOTE**

Before the C5510 DSP became the primary DSP used by Cisco voice gateways, the C549 DSP and the NextPort DSP were also widely implemented. The C549 DSP lacks the channel density and flex-complexity mode that is found on the C5510. Subsequently, the C549 has only a medium-complexity mode where four total calls are supported and a high-complexity mode where only two total calls are supported.

The NextPort DSPs were found exclusively on the 5350, 5400, and 5850 voice gateways. Unlike the C549 and C5510, there are not different complexity modes for the NextPort DSP. Instead, six channels are always available without any codec restrictions. With the introduction of the Cisco High Density Packet Voice/Fax Feature Card (part number AS5X-FC) using the 5510 DSP for the recent 5350XM and 5450XM models, most of the NextPort DSP products are no longer available.

---

An alternative to hard-coding a medium- or high-complexity mode on a C5510 DSP is to use the flex-complexity mode. Flex-complexity mode offers the ability to dynamically handle all the different codec complexities on the same DSP at the same time while only allocating just the resources necessary.

In most situations, flex-complexity mode is the best choice on the C5510 DSP because it offers dynamic complexity selection and increased call densities per DSP. However, it is possible to oversubscribe the C5510 in flex mode, and this results in a blocking design compared to the nonblocking nature of the medium- and high-complexity modes and their fixed DSP channel allocation.

For example, take the scenario of just a single C5510 DSP configured for flex complexity on a gateway. According to Table 7-10, the voice gateway can handle 16 simultaneous G.711 or low-complexity codec calls with this single DSP. However, if two fax relay calls are initiated, only 12 total calls can now be handled by the DSP rather than the original 16. The reason for this is because a medium-complexity codec, such as fax relay, is twice as resource intensive for the DSP in flex mode as a low-complexity codec. If a gateway is engineered to handle a certain call load based on low-complexity codecs on C5510 in flex mode, fax relay calls on this DSP, quickly lowering the supported call load. Calls in excess of what the DSP can support will fail. This is an example of the oversubscription issue for C5510 DSPs in flex mode.

This problem is even more serious with modem relay because it is a high-complexity codec and requires even more DSP resources than a medium complexity codec. Although the calculation of C5510 DSP resources in flex mode can be manually calculated, it is much easier to use the codec calculator tool at Cisco.com. Here you can enter the maximum number of fax and modem relay calls that a gateway will handle; a recommendation reflecting the number of DSPs necessary will be generated. Note that this tool is available only to registered users:

[http://www.cisco.com/pcgi-bin/Support/DSP/cisco\\_prodsel.pl](http://www.cisco.com/pcgi-bin/Support/DSP/cisco_prodsel.pl)

**TIP**

Unlike fax and modem relay, text relay is not a factor when it comes to DSP resource allocation. Because text relay is not resource intensive and it works within any codec's media stream, text relay's impact on DSP resources is negligible. For example, if text relay is configured for a G.729A call, this call is still treated as a call using a medium-complexity voice codec, and no additional DSP resource allocation is necessary for text relay. DSP resource allocation for this G.729A call is the same no matter if text relay is present or not.

---

As shown in Table 7-9, in addition to affecting DSP resources, fax relay and T.37 store-and-forward fax also have a major impact on a voice gateway's CPU utilization and memory. Compared to a regular voice call, fax relay and T.37 use more of the voice gateway's CPU and in the case of T.37, memory resources, too. In fact, the impact on CPU utilization in some cases is often twice that of a normal VoIP call.

The fax relay and T.37 impact on different hardware platforms varies because a number of factors come into play, including the number of pages in the faxes, call per second rate, if any image conversion occurs on the gateway, and so on. The current Cisco voice gateways can handle at least half the total call capacity for the platform as fax relay and T.37 calls. Also, you should be aware that fax relay and T.37 onramp calls have a greater impact on the CPU than T.37 offramp.

In addition to affecting the CPU utilization, T.37 calls to a lesser extent also impact the system memory of the gateway. Compared to normal voice calls, only about an extra 10 MB is needed on the voice gateway per 100 T.37 calls. Unless memory is already running low, this additional memory requirement should not be much of an issue, especially on the newer platforms with larger memory capacities.

Whenever fax relay or T.37 store-and-forward fax is configured on a voice gateway, monitor the CPU utilization and memory statistics of the voice gateway as you approach the point when these calls make up about half the total call capacity. High CPU levels and low amounts of free memory can negatively impact many important functions and processes, so be cautious about adding large numbers of fax relay and T.37 calls to a voice gateway.

## Secure RTP

Defined in IETF RFC 3711, Secure Real-Time Transport Protocol (SRTP) provides for encryption of the RTP protocol used by VoIP. Without SRTP, VoIP conversations can be easily captured and listened to with a simple packet-capture device or software program. SRTP encrypts the VoIP conversations so that they are protected from unauthorized eavesdropping.

One of the main benefits of the SRTP encryption scheme is that only the RTP payload is encrypted. Therefore, secure tunnels for the media do not have to be created, and the voice traffic can be routed normally. In addition, QoS settings in the IP header are not affected, and CRTP can still be used for bandwidth reduction over WANs.

With the increasing usage of SRTP for VoIP, the logical next step is securing modulated data communications that use passthrough and relay over the IP network, too. Much of the emphasis in securing modulated communications over IP has to do with fax traffic. With the appropriate software, extracting fax pages from a packet capture is just as easy as listening to a VoIP conversation.

Unfortunately, some of the transport methods for passthrough and relay do not use an RTP header, which is an obvious requirement for SRTP. Table 7-11 highlights the various passthrough and relay transport methods and their compatibility with SRTP.

**Table 7-11** *Passthrough and Relay SRTP Support*

<b>Passthrough/Relay Transport Method</b>	<b>SRTP Support</b>
Passthrough (including NSE-based modem passthrough and protocol-based fax passthrough)	Supported. (The G.711 codec is used for all forms of passthrough, and it includes an RTP header.)
T.38 fax relay	Not supported. (The T.38 fax relay protocol in Cisco voice gateways uses a UDPTL header. More recent versions of the T.38 specification provide for an RTP header rather than UDP transport layer [UDPTL], but this has yet to be implemented on Cisco voice gateways.)
Cisco fax relay	Supported.
Cisco modem relay	Not supported. (Instead of an RTP header, a Simple Packet Relay Transport [SPRT] header is used.)
Cisco text relay	Supported.

All the supported transport methods in Table 7-11 include an RTP header. Therefore, if securing a fax call with SRTP is your objective, T.38 fax relay is not an option on a Cisco voice gateway. You must use either passthrough or Cisco fax relay. Of course, SRTP is not the only option for securing passthrough and relay traffic. Other options involving secure virtual private network (VPN) tunnels are available if SRTP does not meet your needs.

If you decide to implement SRTP for a passthrough or relay call, take into consideration that a small amount of additional bandwidth is needed for the extra 4 bytes of the SRTP authentication tag. For passthrough calls, this extra bandwidth is negligible, typically an additional 2 percent of overhead. For Cisco fax relay, budget an additional 6 percent of bandwidth per call when SRTP is used.

## Timing and Synchronization

Timing and synchronization on the voice gateway are more critical for fax, modem, and text communications than for voice. Even seemingly minor timing problems can cause fax, modem, and text calls to fail.

The clocking on a voice gateway's digital interfaces and the lack of clock synchronization between DSPs on the originating and terminating gateways are two areas that can present timing and synchronization problems. Of the two, achieving error-free clocking on the voice gateway's digital interfaces is the more critical issue and it is also more prevalent.

Cisco voice gateways have a number of clocking configurations for digital interfaces such as T1 and E1. These clocking configurations allow the Cisco voice gateway to send or receive timing on the digital circuit. In the case of the Integrated Service Routers (ISR) and other select platforms, you can even pass the timing from a digital interface to the gateway's backplane for other modules and components to use. No matter how the timing is configured on a voice gateway, it is critical that the digital link is free of any errors, especially slips.

Slips and other errors on a gateway's digital interface are devastating to modulated communications such as fax, modem, and text. However, the effects of these same types of errors on voice traffic may be undetectable. Therefore, it is imperative that any digital interface that will handle modulated communications traffic be checked to ascertain whether any sort of errors are present. You can find more extensive clocking information for Cisco voice gateways and how to verify and troubleshoot timing errors in the section "Telephony Troubleshooting" in Chapter 12.

The second area where timing and synchronization problems can occur involves the DSPs on peer gateways. When using the passthrough transport method for long fax and modem calls, there can be issues because of the lack of clock synchronization between the DSPs on the originating and terminating voice gateways. Each of these gateways is typically timed from a local time-division multiplexed (TDM) source, a service provider, or the gateway's internal oscillator. For this reason, a clocking discrepancy, ever so slight in some cases, will always exist between the rates that each DSP processes voice packets. The only time that this discrepancy will not occur is if the DSPs in each gateway are pulling their timing from the same clock source. Figure 7-2 shows how the slight clocking discrepancy that exists between gateway DSPs can cause playout buffer problems.

In Figure 7-2, the DSP in the voice gateway on the left is being clocked at a marginally faster rate than the DSP in the voice gateway on the right. This in turn leads to playout buffer overruns for the gateway on the right as G.711 samples fill the playout buffer faster than it can be drained. The opposite occurs for the gateway on the left as it plays out the G.711 samples faster than the playout buffer fill rate and buffer underruns occur.

**Figure 7-2** Possible DSP Playout Buffer Problem for Long Passthrough Calls

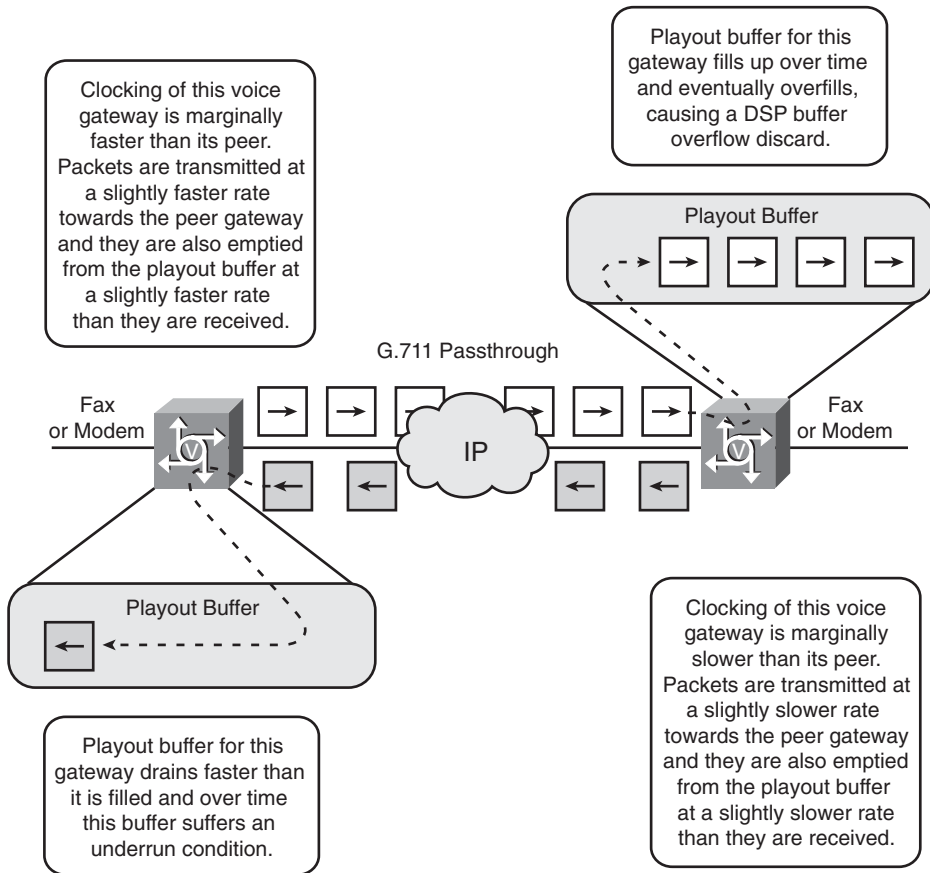

**TIP**

This problem is rarely seen on IOS gateways that use the Telogy DSP firmware. A patented resync feature in the DSP firmware handles this asynchronous clocking problem in most cases, except for large timing discrepancies. Telogy DSP firmware is found on all platforms and models that use the C549 and C5510 DSP chips. Cisco products such as the AS5350, 5400, and 5850 using the NextPort DSP firmware, the 6608, the VG248, and the ATA do not use Telogy DSP firmware and are therefore more susceptible to this problem.

The amount of time it takes for this DSP asynchronous problem to appear can vary greatly because it is fully dependent on how far off the timing is between the DSPs. In most cases, you will not see this problem manifest itself unless large faxes consuming dozens of pages are sent or modem calls are left connected for hours.

Only the passthrough transport method suffers from this problem because of the way G.711 packets are constantly streamed between the two voice gateways. The relay transport method passes data only when necessary, and playout buffers are given multiple opportunities to reset during a typical call. In addition, in the case of fax relay, the playout buffer is statically set to 300 ms, a much larger value than what is typically seen for a passthrough call. Therefore, for long fax and modem calls over an IP network, passthrough is not recommended. Instead, fax relay or modem relay should be used as the transport method.

## Fax Design Considerations

So far, this chapter has dealt with design criteria that is broadly applicable to both passthrough and relay for fax, modem, and text communications. However, in this section, the focus narrows to fax-specific design information. All the material in this section pertains only to design considerations for transporting fax data over passthrough and relay.

## Gateway Interoperability Considerations

Because of the various methods for transporting fax calls over IP, the interoperability of different voice gateways must be considered when creating a network design. Table 7-12 provides a quick summary of the different fax transport methods that are available for fax. The technical details of these methods have already been discussed in Chapters 4 and 5.

From a design perspective, these different transport methods for fax highlighted in Table 7-12 require due diligence in verifying that a voice gateway supports a chosen transport method. Even between Cisco voice gateways, some well-known caveats concerning fax passthrough and relay support exist:

- The Cisco ATA does not support fax relay and only supports NSE-based passthrough.
- Platforms using the NextPort DSP hardware, including the AS5350, AS5400, and AS5850, support only T.38 fax relay. Cisco fax relay is not supported.
- Voice gateways (including the VG248) that use the SCCP or “skinny” voice signaling protocol do not support protocol-based T.38 or pass-through. NSEs must be used for a passthrough or T.38 fax relay switchover.
- The 6608 and 6624 voice gateways support only Cisco fax relay and NSE-based passthrough.
- Protocol-based pass-through is not currently supported by Cisco voice gateways for MGCP. Just like the SCCP voice signaling protocol, the MGCP protocol on Cisco voice gateways supports passthrough only if an NSE-based switchover is used.

**Table 7-12** *Passthrough and Relay Transport Methods for Fax*

Transport Method	Protocol/Switchover	Explanation
Passthrough	G.711 (NSE-based modem passthrough)	This G.711 passthrough method implements a switchover that is handled by Cisco proprietary NSEs. This transport method is often referred to as modem passthrough because this is the IOS command used to configure it.
	G.711 (protocol-based fax pass-through)	This G.711 passthrough method handles the switchover within the H.323 or SIP signaling protocol. The SCCP and MGCP signaling protocols do not support protocol-based pass-through. This transport method is often referred to as pass-through because this keyword is used by the <b>fax protocol</b> command during configuration.
Relay	T.38 Fax relay (NSE-based switchover)	This is the standards-based version of fax relay that works only between Cisco voice gateways, because of the proprietary NSE switchover.
	T.38 fax relay (protocol-based switchover)	This is the standards-based version of fax relay that uses a switchover in the protocol stack of the voice signaling protocol. This ensures interoperability with third-party voice gateways.
	Cisco fax relay (RTP switchover)	This is the Cisco prestandard fax relay implementation that is supported only by Cisco voice gateways.

The Cisco voice gateways with the most flexibility are the IOS-based voice gateways running the Telogy DSP firmware on the C549 and C5510 hardware. These gateways typically support all the fax passthrough and relay transport options in Table 7-12, unless they must run the SCCP or MGCP voice signaling protocols. As noted previously, SCCP gateways support only NSE-based switchovers for passthrough and T.38 fax relay, whereas MGCP supports only NSE-based passthrough, too.

If third-party voice gateways are also included in a network design involving fax over IP, your choices of fax transport methods are restricted to protocol-based pass-through and protocol-based T.38. The other transport methods involve Cisco proprietary switchovers or protocols, which third-party voice gateways would not support.

Protocol-based pass-through interoperates with many third-party voice gateways, but it is not a standard. This transport method works because it uses procedures within the H.323 or SIP signaling protocol to convert the call to passthrough. The proposed standard for passthrough is V.152, but this specification has not been implemented on Cisco voice gateways. You can find more information about ITU-T V.152 in the section “A Future Look at ITU-T V.152” in Chapter 4, “Passthrough.”

The only true standards-based solution for transporting fax over IP is protocol-based T.38 fax relay. In most circumstances, this is going to be your best method for achieving successful fax transmissions between Cisco voice gateways and other vendors. Nonetheless, for T.38 fax relay and even protocol-based pass-through it is recommended to consult the other voice gateway’s vendor to confirm support of either of these IP fax transport options.

## Error Correction Mode

The Error Correction Mode (ECM) feature provides a means for fax machines to ensure error-free page transmissions. This feature is optional, and not all fax devices support ECM. Even on fax machines that do support ECM, it can usually be disabled.

The ECM feature can be of critical importance for faxed information, especially contracts and legal documents. Without the ECM feature enabled, a small percentage of scan-line errors can occur without causing a complete call failure. This in turn may cause some parts of the received page to contain viewable errors or slight corruption.

All the technical details concerning ECM have already been covered in the section “Understanding Error Correction Mode (ECM)” in Chapter 2, “How Fax Works.” This section explores the ECM feature from a network design perspective, covering the advantages and disadvantages of the feature and some best practices for its implementation.

The main advantage of ECM is that you are ensured that an exact copy of the original document will arrive at the destination fax machine. As mentioned previously, this can be critical for many types of documents. In addition, ECM can eliminate the need to re fax documents because the quality of the received document was poor.

Because of the ECM feature’s tenacious behavior in ensuring an error-free transmission, ECM fax calls will fail before an errored fax page is allowed to go through. Although the majority of the time the sending fax machine will redial and try again at a later time, some consider this a disadvantage of ECM. They would prefer that the fax go through with minor errors rather than not go through at all.

Subsequently, ECM is not very tolerant of packet loss. In lab testing, ECM fax calls start to fail much sooner as the amount of packet loss is increased compared to non-ECM fax calls, which handle much higher levels of packet loss before failing. Furthermore, even if an ECM fax call does not fail because of packet loss, numerous retransmissions of errored scan lines can cause fax transmissions to last a long time. This is inefficient for customers that handle a large amount of fax traffic.

The need for non-ECM fax calls occurs in situations where the call must traverse an IP network that is not under your direct control, such as a service provider’s network or the Internet. In these types of scenarios, you cannot control the amount of packet loss and jitter. Therefore, getting non-ECM faxes to go through with minor errors is still better than ECM faxes not going through at all. Naturally, in IP networks where packet loss is low, the advantages of ECM will outweigh any disadvantages.

The ECM feature is activated during the negotiation phase of the fax call between the originating and terminating fax devices. When using passthrough for the fax call, this negotiation is passed seamlessly between the fax machines using the G.711 codec. However, with fax relay, Cisco voice gateways offer the user the ability to disable the ECM feature by manipulating bit 27 of the DIS message. Bit 27 in the DIS message is used by the terminating fax device to signal its support of ECM. Remember that with fax relay calls, the voice gateway demodulates the fax T.30 messages. This allows the gateway to manipulate certain bits in the fax negotiation messages that control features such as ECM.

Both the T.38 and Cisco fax relay transport methods can flip bit 27 to signal that ECM is not supported even though the terminating fax device may have set the bit to signal that ECM is supported. When the originating fax device receives the DIS message, it sees that bit 27 indicates the lack of ECM support on the terminating fax device and then proceeds with a non-ECM fax call. Figure 7-3 shows this process.

**Figure 7-3** *Disabling of the ECM Feature by a Cisco Voice Gateway*

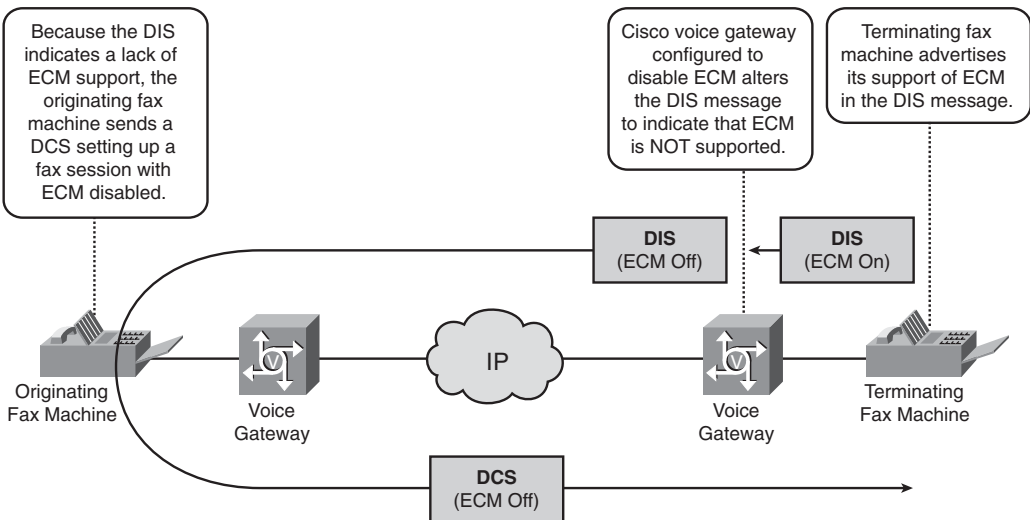

By default, fax relay configurations on Cisco voice gateways do not disable ECM in the manner shown in Figure 7-3, except for the 6608 Catalyst blade. However, if you decide that ECM should be disabled for fax calls on IOS voice gateways, you can use the IOS configuration command **fax-relay ecm disable** under the VoIP dial peer, or in the case of MGCP use the command **no mgcp fax t38 ecm**. You can find more information about these configuration commands in Chapter 10.

When ECM is disabled on a Cisco IOS voice gateway as diagrammed in Figure 7-3, a feature known as fax relay packet loss concealment is enabled. This feature further enhances the robustness of non-ECM fax calls by replacing corrupted scan lines with the previous scan line. For a few corrupted scan lines on a page, this feature is hardly noticeable, and it keeps error-free scan lines from arriving at the terminating fax device. However, when many scan lines are corrupted, this feature makes text “bleed” down the page. Basically, the packet loss concealment feature handles minor packet loss really well, but it does not compensate for high percentages of packet loss.

In most cases, the decision to use the ECM feature when implementing fax relay is best left up to the individual fax machines. Subsequently, if ECM is successfully negotiated by the fax endpoints, the voice gateway does not alter that decision. However, if the need exists for forcing ECM to be disabled for a fax relay call, this can be accomplished by Cisco voice gateways.

## Super G3

Super G3 (SG3) or V.34 faxing uses different modulations and signaling than a normal G3 fax call. Rarely is this a problem, however, because SG3 is backward compatible with the ubiquitous G3 fax standard. If either the originating or terminating fax device does not support SG3, the fax transmission falls back to a normal G3 fax call. For more information about the technical details of SG3, see the section “Super G3 Faxing” in Chapter 2.

Cisco voice gateways do not support SG3 fax transmissions when either T.38 or Cisco fax relay is configured. Furthermore, unlike a G3 fax call, an SG3 call does not contain the V.21 flags necessary for the Cisco voice gateway to identify the call as a fax call. Therefore, T.38 and Cisco fax relay and protocol-based fax pass-through will not activate, leaving the fax call stuck with the configured voice codec. The only true support of SG3 on Cisco voice gateways is accomplished using NSE-based modem passthrough.

Occasionally, a situation can arise where SG3 fax machines never fall back to G3 mode when trying to use fax relay as the transport method. Without a fallback to a G3 negotiation, fax relay is never initiated by the Cisco voice gateways. The SG3 fax machines can potentially keep trying to negotiate over a highly compressed voice codec such as G.729 without success. The fax call eventually fails.

Although this situation and other SG3-to-G3 interoperability issues involving fax relay through a Cisco voice gateway are somewhat uncommon, they still pose problems that are easily fixed. The following solutions are how SG3 fax transmissions should be handled for Cisco voice gateways configured for fax relay:

- **Manually disable the SG3 feature on the fax machine itself:** Many fax devices tout this feature with some sort of marking to the effect of “High-Speed Faxing,” “Super G3,” or “V.34 Fax.” Disabling SG3 at the fax machine itself ensures that this specific fax device will negotiate only standard G3 fax calls. Unfortunately, this solution does not scale for large numbers of fax machines spread across different locations.

---

**TIP**

The Super G3 feature requires ECM to be enabled. If ECM is not enabled, Super G3 will not work. On certain fax devices where a specific configuration option to disable SG3 does not exist, but an ECM disable option is available, disabling ECM will disable SG3.

---

- **Enable modem passthrough as the transport method:** Modem passthrough is the only transport option that handles SG3 calls at their native speeds. However, because of its NSE-based switchover mechanism, it does not interoperate with third-party equipment and can be implemented only between Cisco voice gateways. In many cases, fax relay is configured to handle G3 fax calls on a Cisco voice gateway in combination with modem passthrough to handle any SG3 fax calls. This scenario is covered for the MGCP voice signaling protocol in a sample configuration in the section “T.38 Fax Relay and Modem Passthrough Configuration for MGCP” in Chapter 10. Of course, this same sort of solution can be applied to the H.323, SIP, and SCCP protocols, too.
- **Enable the feature Fax Relay Support for SG3 Fax Machines at G3 Speeds:** Available in IOS Release 12.4(4)T and later, this feature suppresses the initial SG3 signaling so that the fax machines believe that only a standard G3 fax call is possible. Because it uses the V.34 modulation, SG3 is dependent on the Calling Menu (CM) message for bringing up V.34. The V.34 modulation was discussed in detail in the section “Modem Call Analysis” in Chapter 1 “How Modems Work.” By squelching this CM message, this feature prevents the setup of V.34 and, consequently, SG3. This feature is controlled by default the commands **fax relay sg3-to-g3** for H.323, SIP, and SCCP voice gateways and the command **mgcp fax-relay sg3-to-g3** for MGCP. You can find more information about these commands in Tables 10-7 and 10-11 in Chapter 10. In addition to a specific software requirement, only certain hardware supports this

feature. See the online document “Fax Relay Support for SG3 Fax Machines at G3 Speeds” at Cisco.com for more detailed information about the specific hardware requirements.

The decision on how to handle SG3 when transporting faxes over IP networks is often overlooked. Potentially, this can cause unnecessary problems later upon implementation. Therefore, it is recommended to adopt one of the solutions above to eliminate any SG3-related issues and to ensure a high fax call success rate.

## Hairpin Calls

A hairpin call occurs when a standard inbound telephony call is simply routed back out another telephony interface on the same voice gateway. A VoIP component is not present for this sort of call. This type of call is also commonly referred to as a POTS-to-POTS call, TDM switching, or a TDM hairpin call.

A scenario involving a hairpin call is illustrated in Figure 7-4. In this figure, a Cisco voice gateway is connected to the PSTN by a digital T1 or E1 circuit. Voice calls are routed via VoIP to Unified CM, whereas fax calls are “hairpinned” from the PSTN interface to another T1/E1 digital interface on the gateway, which connects directly to a fax server.

**Figure 7-4** *Hairpin Call*

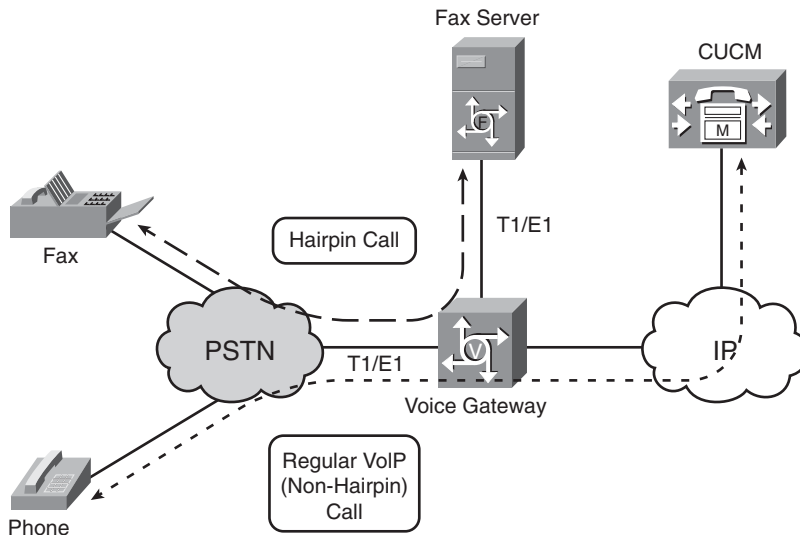

The most important aspect of any hairpin call on a Cisco voice gateway is whether the DSP can be dropped from the call after it is established. If the DSP can be dropped out of the call, a TDM connection through the voice gateway occurs, and this is the ideal scenario. All

the bits transmitted between these ports are unaltered by the voice gateway. In Figure 7-4, a hairpin call with the DSP dropped is equivalent to the fax server being connected directly to the PSTN without the gateway present.

In some cases, because of hardware restrictions or user configuration, DSPs must remain involved for the call duration. With DSP involvement, the bits will always be altered to some extent as the DSP processes the call.

With fax calls, this DSP involvement can be plainly seen by running the command **debug fax relay t30 all-level-1**. You will see that by default T.38 fax relay occurs between the DSPs handling the hairpin call. This does not necessarily result in problems, but bypassing the DSP is the better option when it is possible. Naturally, when the DSP is bypassed, these debugs will not be present because the DSP has been removed from the call path.

A pure TDM hairpin call in its simplest form occurs within a single module slot of a voice gateway. This intraslot TDM hairpin can occur on digital or analog voice ports and is typically dependent on the module installed in the slot. For example, on ISR voice gateways such as the 2800 and 3800 series, a two-port FXS card (VIC2-2FXS) inserted into an HWIC slot on the motherboard module slot 0 will automatically perform TDM hairpins between the two FXS ports.

The other type of “DSP-less” TDM hairpin calls occur between module slots on a Cisco voice gateway. An interslot hairpin call requires that the voice gateway contain a TDM backplane to link the module slots and that the modules themselves participate in the timing that is occurring across this backplane.

Although numerous voice card and voice module combinations are possible when it comes to TDM hairpin calls, a few basic rules apply when planning for TDM hairpin calls on Cisco voice gateways:

- Both analog and digital voice ports support TDM hairpin calls. In addition, the two ports involved in a hairpin call do not have to match from an analog and digital perspective. You can have one port be an analog port and the other be a digital port during a TDM hairpin call.
- The command **local-bypass** is enabled by default, and it controls the TDM hairpin call feature for a particular module slot on a Cisco voice gateway. The negation of this command, **no local-bypass**, forces the DSP to be involved for all hairpinned calls involving this module slot. This command is configured under the **voice-card** submenu.
- Performing TDM hairpin calls across module slots (interslot) requires that the gateway have a TDM backplane, such as the 2800 and 3800 series of Cisco voice gateways. Other gateways without a TDM backplane are only capable of intraslot TDM hairpin calls. These gateways can pass calls between slots, but they will not be in a true TDM fashion, and the DSP will be involved.

- When performing interslot TDM hairpin calls, the DSP types must be the same. You cannot have C549 DSPs attached to one voice port and C5510 DSPs being used by the other voice port. For example, the NM-HDV module uses C549 DSPs and is capable of interslot TDM hairpin calls only with another NM-HDV module. Hairpin calls between an NM-HDV and an NM-HDV2 or other C5510-based module require that DSPs be involved.
- Both module slots in an interslot TDM hairpin call must be part of the gateway's TDM backplane clocking scheme. This is accomplished using the **network-clock-participate** command. If a module slot is not tied to the clocking used on the TDM backplane, the DSP must stay involved with the transmission, and it cannot drop out.
- Notable modules that do not support intraslot or interslot TDM hairpin calls are the older NM-1V, NM-2V, and NM-HDA.

You should always strive for TDM hairpin calls where the DSP is dropped from the call to ensure the best call success rate. However, for situations where a TDM hairpin call is not possible, a hairpin call with DSP involvement and T.38 fax relay between the DSPs should suffice.

## Fallback

The fallback feature on Cisco IOS voice gateways provides a means for an alternate fax transport protocol to be used if the initial T.38 fax relay transport method fails to negotiate successfully. Fallback is only available with T.38 fax relay on H.323 and SIP voice gateways, and two different options are available. The fallback itself occurs seamlessly with either option, and in most cases the fax machines never realize that a fallback has even occurred.

The first fallback option occurs by default, without any additional configuration, whenever NSE-based T.38 fax relay is enabled for the H.323 and SIP protocols. The enabling of this type of fallback is accomplished by the IOS configuration command **fax protocol t38 nse**. This command, as defined by Table 10-5 in Chapter 10, instructs the voice gateway to implement T.38 fax relay using a switchover of Cisco proprietary NSEs. A detailed explanation of the NSE-based T.38 fax relay switchover was covered previously in the section “NSE-based Switchover for T.38” in Chapter 5.

However, in the event that this NSE-based T.38 switchover fails, the Cisco voice gateway immediately tries protocol-based T.38. The assumption here is that the voice gateway that does not support an NSE-based switchover may be a Cisco voice gateway incorrectly configured for protocol-based T.38 fax relay. Another possibility is that a third-party device that will support only a protocol-based T.38 switchover is on the other end of the call. Either way, if an NSE-based T.38 fax relay switchover fails, a protocol-based T.38 switchover is tried in the hopes of completing a successful fax call.

What this means from a network design perspective is that third-party voice gateways can be integrated into an architecture where NSE-based T.38 is the default configuration. A delay might occur in the switchover as the NSE negotiation fails, but a successful T.38 fax

call using the voice signaling protocol stack should still be established. In addition, Cisco voice gateways that are configured for protocol-based T.38 can interoperate with NSE-based voice gateways. Just be aware that in rare situations the delay associated with falling back to another transport method can be too long for some fax devices, and the call might get disconnected early and fail.

The other fallback option is explicitly configurable via the CLI using the command **fax protocol t38 fallback** or **fax protocol t38 nse fallback** for H.323 and SIP voice gateways. These two commands allow for fallback to occur for both NSE-based T.38 and protocol-based T.38 fax relay.

The specific fallback options include the additional transport methods of **cisco** (Cisco fax relay), **pass-through**, and **none**. If for whatever reason T.38 fax relay is not supported or enabled, a completely different transport method can be specified. Figure 7-5 highlights a scenario where a fallback to pass-through occurs.

**Figure 7-5** T.38 Fax Relay Fallback to Pass-Through

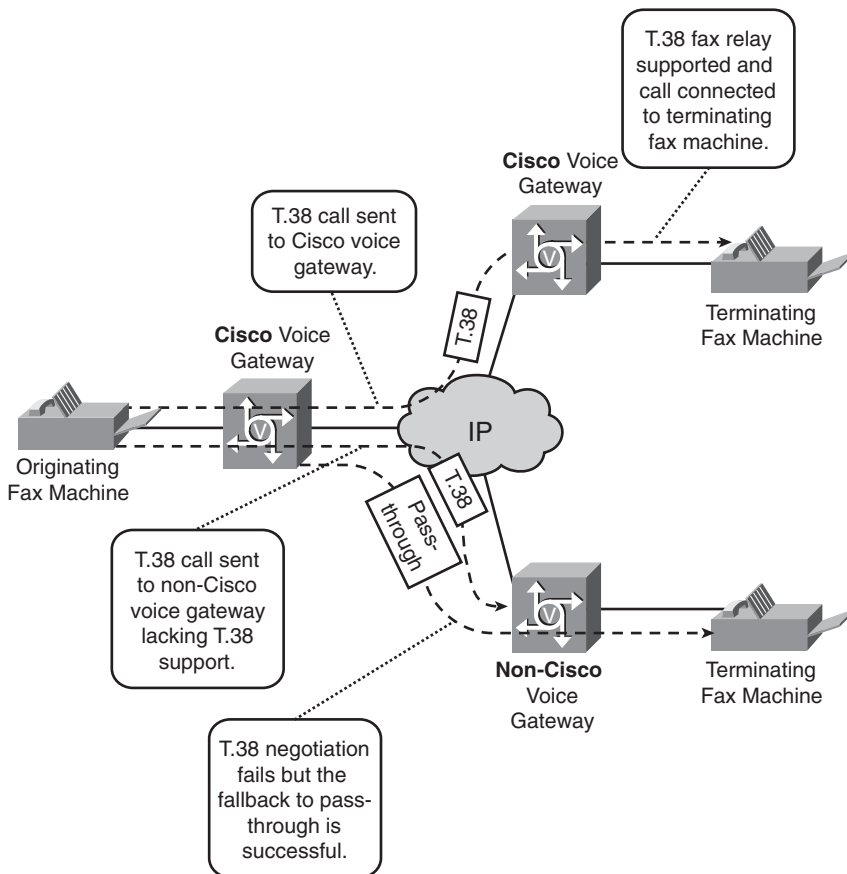

In Figure 7-5, using the IOS configuration command **fax protocol t38 fallback pass-through g711ulaw**, the originating Cisco voice gateway on the left side of the diagram successfully places a T.38 fax relay call to another Cisco voice gateway. A similar call to a third-party voice gateway lacking T.38 fax relay support fails to negotiate. However, instead of the fax call failing completely, a pass-through negotiation immediately follows. The pass-through transport method is supported by the non-Cisco voice gateway, and the fax call is successfully established with the terminating fax machine.

Although the two T.38 fax relay fallback options mentioned in this section are not always necessary, they do provide additional means of integrating different fax transport methods and switchovers. If the need exists to integrate third-party voice gateways lacking T.38 fax relay support into a network where T.38 fax relay is the primary transport method, the fallback option illustrated in Figure 7-5 is invaluable.

The most important design consideration concerning fallback is that in ideal network planning situations, this feature is not necessary. From a practical perspective, configuring all voice gateways to use the same T.38 fax relay transport method and switchover is the best recommendation. The fallback feature should be used only in situations where the same T.38 transport and switchover method cannot be implemented throughout the network.

## T.37 Store-and-Forward Fax

As discussed in the previous chapter, T.37 store-and-forward fax provides a conversion between faxes and e-mail. This is a unique process for handling fax communications, and it allows T.37 to serve as an alternative transport method to fax passthrough and relay.

The ability to send and receive faxes directly from an e-mail client is the main allure of T.37. Without T.37, a typical fax scenario could be similar to the following:

- 1 Print a document.
- 2 Go retrieve it from a printer.
- 3 Walk the document over to an office fax machine.
- 4 Possibly wait for someone else to finish sending or receiving a fax.
- 5 Manually fax the document.

Compare this process to a T.37 scenario where you just e-mail the document and it automatically arrives at its final destination as a standard fax.

Receiving documents is also just as simple with T.37. Instead of walking over to the office fax and picking through the pile of received faxes, T.37 delivers the fax directly into your e-mail inbox. When it comes to efficiently sending and receiving fax documents, T.37 has a decided advantage over traditional faxing methods.

Because T.37 converts faxes to e-mail, the benefits of e-mail can be exploited and applied to faxes. For example, you can send a fax e-mail to a distribution list and fax a document to many people at once.

However, T.37 has its share of disadvantages, too. The one major disadvantage involves the fact that T.37 breaks the real-time nature of a traditional fax call. This makes it difficult to confirm that the fax ever reaches its final destination. In a traditional real-time scenario, the originating fax machine sends the document directly to the final destination. If the transaction is successful, the originating fax can instantly print a confirmation report. If the transaction is not successful, an error message is reported, and the fax failure is noted in transmission reports from the fax machine.

Receiving any sort of confirmation or status as to the delivery of a fax to its final destination with T.37 depends on DSN and MDN messages. Although these messages are potentially useful, they lack wide-ranging support from mail servers and e-mail clients. This, in turn, makes receiving status or delivery information for fax e-mail potentially unreliable.

Another disadvantage of the Cisco T.37 implementation is the lack of ECM support. Cisco voice gateways performing the T.37 onramp and offramp functions will not support the ECM option, and this leads to a couple of problems. In addition to potential image-quality problems in the TIFF file generated by an onramp gateway, certain errors in the scan lines can cause the TIFF to be incomplete and, even worse, the call may fail. Make sure that any digital interfaces used to receive onramp faxes are free of errors to mitigate the lack of ECM support with T.37.

---

**TIP**

A solution to consider that remedies T.37 disadvantages while still maintaining its advantages are fax servers. Fax servers can provide the e-mail “look and feel” of T.37, but they do not rely on DSN and MDN for status and confirmation. Instead, the fax servers send the fax using a real-time protocol such as T.38 fax relay and then can pass a true confirmation on to the user. More information about fax servers and how they can be integrated into Cisco voice networks is discussed in the next chapter.

---

A design consideration that is often overlooked when implementing T.37 store-and-forward fax on a Cisco IOS voice gateway is the greater amount of memory and CPU that is utilized by a T.37 call compared to a regular voice call. For more information about the impact of T.37 on a voice gateway’s resources, refer back to the section “Resource Utilization,” earlier in this chapter.

An interesting T.37 integration worth noting involves the Cisco Unity product. Although Cisco Unity is a well-known, feature-rich voice-mail product, it can also be integrated directly with T.37 onramp and offramp gateways. Designed for simple, small-scale,

low-traffic fax needs, a T.37 and Unity integration allows for users to receive faxes in their Unity inboxes and to send faxes directly from e-mail.

Implementing this solution requires the Unity IP Fax Configuration wizard and properly configured onramp and offramp voice gateways. The Unity IP Fax Configuration wizard along with links for the onramp and offramp gateway configurations, a training video, and other documentation can be downloaded from the following site:

[http://www.ciscounitytools.com/App\\_IPFaxConfigurationWizard.htm](http://www.ciscounitytools.com/App_IPFaxConfigurationWizard.htm)

Depending on the situation, T.37 store-and-forward fax is a viable alternative to real-time fax protocols such as fax relay and passthrough. This fax transport method is unique in that it takes advantage of the SMTP protocol for transferring fax data, and this allows for distinct solutions, such as a direct integration with Cisco Unity. However, you need to fully understand the advantages and disadvantages of T.37 and its design constraints before selecting it as your fax transport method.

## Fax Detect Script

Cisco IOS gateways can run TCL scripts for handling a wide variety of both voice and fax features. Common TCL scripts for fax include the onramp and offramp scripts that are used when configuring T.37 store-and-forward fax. Another TCL script that is available from the Cisco website is the fax detect script. Registered users can download this script at <http://www.cisco.com/cgi-bin/tablebuild.pl/tclware>.

The fax detect TCL script allows for Cisco IOS voice gateways to provide a “single number reach” capability for voice and fax calls. One telephone number can be used as a voice line and fax line. The fax detect script makes the determination of whether the incoming call is a voice call or a fax call, and then routes the call appropriately. Voice calls are passed to an IP phone or another voice gateway, and fax calls are converted to an e-mail attachment using T.37 store-and-forward fax. Figure 7-6 provides a sample scenario of how the fax detect script can be implemented.

As shown in Figure 7-6, the fax detect script integrates easily into a T.37 onramp gateway. This allows incoming calls that are determined to be faxes to be converted into an e-mail attachment. This fax e-mail can then be accessed by an e-mail client for viewing.

The fax detect script identifies an incoming call as a fax call using one of two methods, a DTMF tone from the calling party or CNG tone detection. The voice gateway can play an optional audio prompt when the call is answered. This audio prompt can tell the user to press a certain DTMF number on their phone to indicate a fax call. The gateway then routes the call as a fax call, and the user presses Start on the fax machine to initiate the fax transmission.

Figure 7-6 *TCL Fax Detect Script*

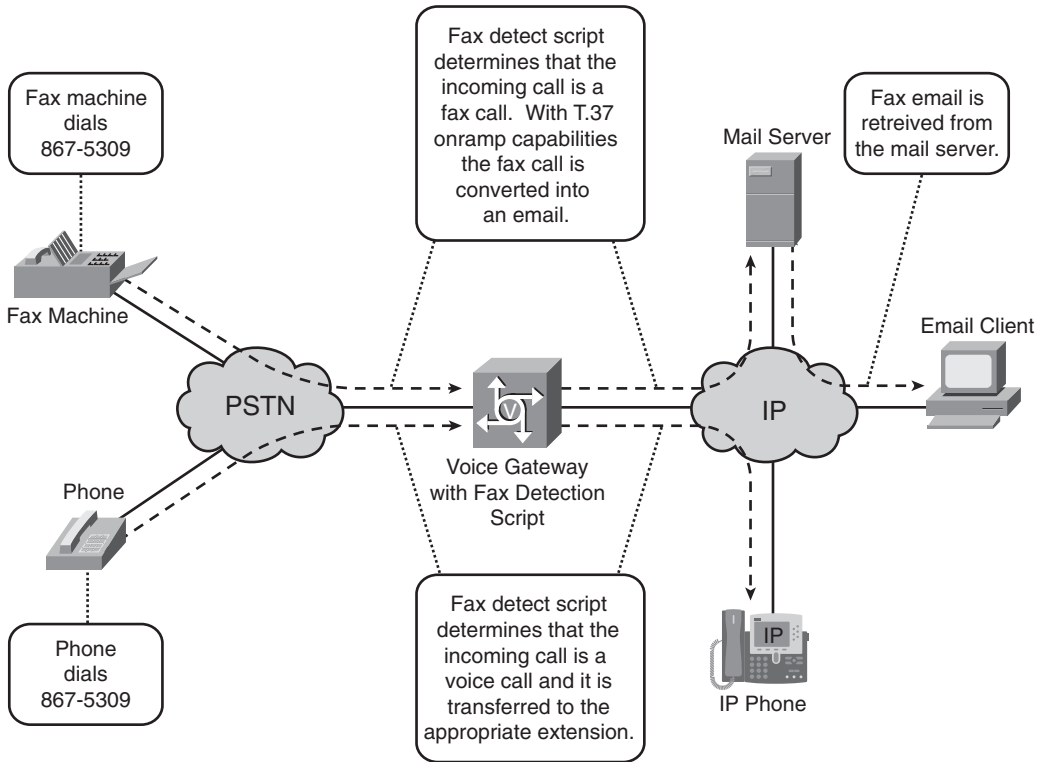

With CNG tone detection, the voice gateway listens for the 1100 Hz CNG tone. The calling fax devices play this tone, and the voice gateway listens for CNG even if an audio prompt is not present. The CNG tone is discussed in detail in the section “CNG Tone” in Chapter 2. The fax detect script requires the reception of three CNG tones before the call is classified as a fax call and routed as such. The CNG tone detection method is used frequently because most fax machines are automated and users do not manually place the calls and listen for audio prompts.

**TIP**

On the 5350, 5450, and 5850 voice gateways using the NextPort DSP modules and the fax detect script, calls are classified as fax calls after only two CNG tones. Also, there is a voicecap setting of v319=1 that can be configured on these platforms to lower this to one CNG tone. The caveat with this low of a setting, however, is that a normal voice conversation might trigger the fax detect script.

The voicecap feature on the 5350, 5450, and 5850 voice gateways using NextPort DSP modules can be configured using the **voicecap configure** and the **voicecap entry** commands. Refer to the document “Cisco IOS Voice Command Reference” for IOS Release 12.3T at Cisco.com for more information about configuring the voicecap feature.

---

Unfortunately, there can be some issues when depending on CNG tone detection for making the determination that an incoming call is a fax call. One problem is that many older fax machines (produced before 1995) do not send CNG tones. Another problem is that when some models of fax machines detect a person answering a call, they disable CNG. Therefore, when the audio prompt answers the incoming call on a voice gateway running a fax detection script, the fax machine hears the voice from the audio prompt and stops sending CNG. Without three CNG tones, the fax detect script’s CNG detection function will never identify the incoming call as a fax call.

Many options exist for customizing the TCL fax detect script on IOS gateways. These options include different fax detection modes and the ability for users to create their own audio prompts. More information about these additional options and configuration examples and troubleshooting tips can be found online at Cisco.com in the document “Configuring Fax Detection.”

For unique applications of the TCL fax detect script, Cisco offers assistance in creating a custom script for your voice gateway through the Cisco Developer Support Program. You can find more information about the Cisco Developer Support Program at <http://www.cisco.com/go/developersupport/>.

In addition to TCL, VoiceXML can be used to create a fax detect script. However, Cisco does not provide a VoiceXML fax detect script for download, so you must create your own. Assistance in creating a VoiceXML script can be obtained through the Cisco Developer Support Program. Additional information on VoiceXML and fax detection can be found online at Cisco.com in the document “Configuring Fax Detection for VoiceXML.”

## Unified CM Integration

The Unified CM product is the heart of most Cisco IP telephony deployments. Subsequently, its support of fax is a common design concern. After all, to fully migrate a legacy voice infrastructure over to IP, Unified CM must be able to handle both voice and fax communications.

In the past, fax support on Unified CM has lagged behind the fax capabilities of the Cisco voice gateways. This is one of the reasons for the implementation of Cisco proprietary NSE packets for handling the fax switchover. With NSE packets, voice gateways could bypass Unified CM whenever a fax switchover was necessary but not supported by Unified CM within the voice signaling protocol stack. Figure 7-7 illustrates an NSE-based T.38 fax switchover with Unified CM.

**Figure 7-7** NSE-Based T.38 Fax Relay Switchover with Unified CM

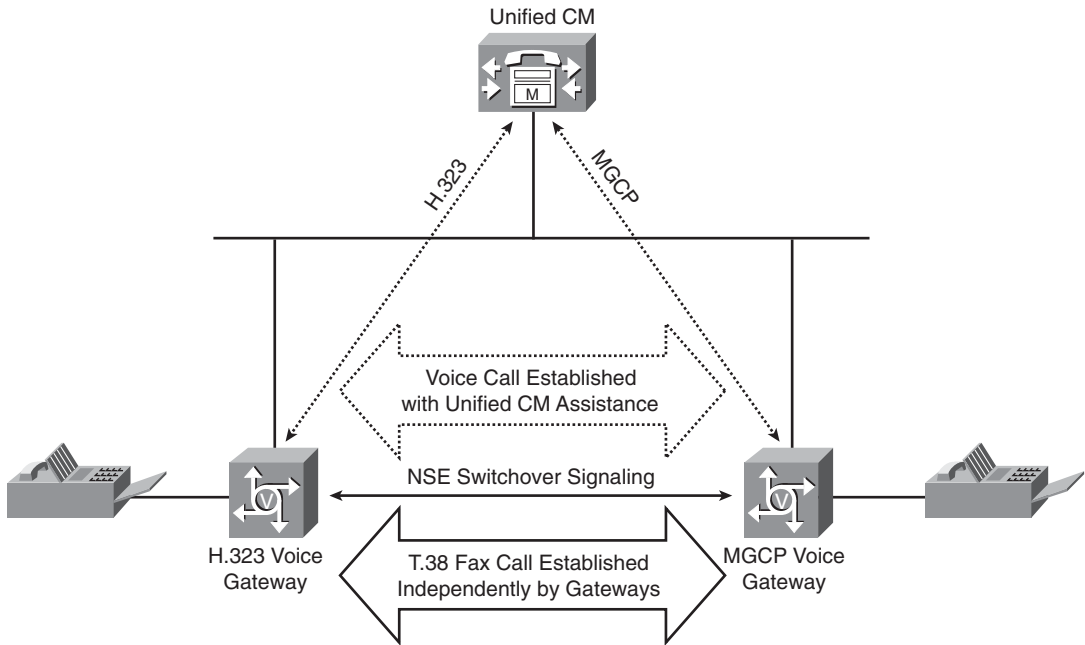

In Figure 7-7, Unified CM successfully establishes a voice call between an H.323 and an MGCP voice gateway. When V.21 fax flags are detected, the voice gateways need to switch over to T.38 fax relay so that the call can be properly handled as a fax call rather than a voice call. However, if Unified CM cannot support T.38 within the H.323 and MGCP protocol stack, the voice gateways can use an NSE switchover. This effectively bypasses the H.323 and MGCP voice signaling protocols and Unified CM, forcing the voice gateways to transition the initial voice call to T.38 fax relay on their own via the media stream.

**TIP**

Support for NSE-based switchovers such as T.38 fax relay can be signaled ahead of time by the voice gateways using their respective voice signaling protocols. This proactively confirms that an NSE-based switchover can be handled by both voice gateways during the initial call setup. Within the H.323 call control protocol, the NSE switchover capability is indicated by a nonstandard capability setting in the H.245 Terminal Capability Set (TCS) message. For the SIP and MGCP call control protocols, the NSE switchover capability is indicated by the X-NSE attribute found in the SDP portion of certain SIP and MGCP messages. However, Unified CM drops optional capability attributes such as these because they are not recognized, and this causes the voice gateways to think that the peer gateway cannot handle an NSE switchover.

To remedy this scenario, IOS gateways include a **force** option in the **fax protocol t38 nse** command. The **nse force** option instructs the voice gateway to use an NSE-based switchover even if a confirmation of NSE support has not been obtained. In most Unified CM deployment models where NSE-based T.38 fax relay is being used, the **nse force** option will need to be implemented. You can find more information about the **fax protocol nse force** command in Table 10-5 of Chapter 10 as well as the section “Validating NSE Switchover Support” in Chapter 12.

More recent versions of Unified CM have added support for T.38 fax relay in the protocol stack of the voice signaling protocol. Assuming that the appropriate Unified CM version is being used, an NSE-based switchover between the Cisco voice gateways is no longer necessary, especially when H.323, SIP, and MGCP are the voice signaling protocols. Figure 7-8 illustrates Unified CM participation for a protocol-based T.38 fax relay switchover.

**Figure 7-8** Protocol-Based T.38 Fax Relay Switchover with Unified CM

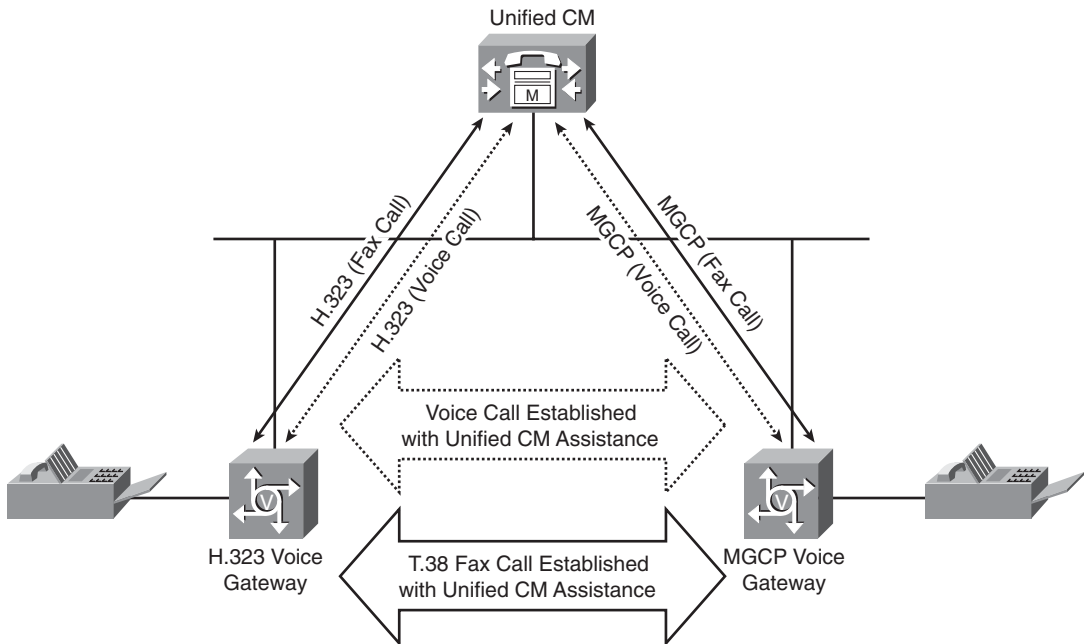

Although H.323 and MGCP voice gateways are illustrated in Figures 7-7 and 7-8, a SIP gateway could just as easily have been substituted for either gateway. The one major exception that occurs for the scenario modeled in Figure 7-8 is for voice gateways running SCCP. SCCP supports only NSE-based T.38 fax relay.

**TIP**

Cisco fax relay cannot directly integrate with Unified CM because it does not allow for the voice signaling protocol to handle the switchover. The switchover can occur only through RTP payload exchanges, as explained in the section “Cisco Fax Relay” in Chapter 5. Voice gateways can implement Cisco fax relay in Unified CM environments, but the voice gateways themselves will control the switchover in a manner similar to that shown in Figure 7-7.

With protocol-based T.38 support, Unified CM now understands T.38 communications and switches over to T.38 using standards-based methods. This now allows Unified CM to integrate directly with third-party H.323 and SIP gateways using T.38 and IP fax servers. Fax server integration with Unified CM is discussed in detail in the next chapter.

The critical piece of information necessary for deploying protocol-based T.38 with Unified CM is the software version where Unified CM picked up T.38 support for a particular voice signaling protocol. Table 7-13 highlights the Unified CM releases where T.38 support for the H.323, SIP, and MGCP signaling protocols was integrated.

**Table 7-13** *Protocol-Based T.38 Fax Relay Support in Unified CM*

<b>T.38 Signaling Protocol Support</b>	<b>Cisco Unified CM Software Release</b>
H.323 support for T.38	4.1(1), 4.2(3), 5.0(1), and 6.0(1)
H.323 and MGCP support for T.38	4.2(3) and 6.0(1)
H.323 and SIP support for T.38	5.0(1) and 6.0(1)
H.323, SIP, and MGCP support for T.38	6.0(1)

You should realize that the software versions listed in Table 7-13 indicate the initial integration point for the support of the T.38 fax relay protocol. Subsequent releases following these initial release points will naturally also have the same T.38 support within a given major release. A major release is indicated by the first number of the Unified CM version. For example, the 5.0(1) release in Table 7-13 means that any 5.x release has the same T.38 support. The 4.2(3) release indicates that any 4.x release following this version, such as 4.3(1), will also contain the noted T.38 support.

As shown in Table 7-13, starting in Unified CM Release 6.0(1), full T.38 fax support over the H.323, SIP, and MGCP voice signaling protocols is available. Software releases before 6.0(1) contain support only for select voice signaling protocols. To achieve the greatest interoperability with T.38 fax relay in Unified CM deployments, the 6.0(1) release or later is recommended.

## Comparing Fax Passthrough and Fax Relay

One of the most common design questions about transporting fax over IP has to do with selecting passthrough or relay as the transport method. The resounding question from a network design perspective is “which one is better?”

Unfortunately, the answer to this question is usually not simple and depends on a number of factors, most of which have already been discussed in this chapter. Therefore, the best way to decide between a fax passthrough or relay implementation is to consider the differences between these two transport methods before making a decision. Table 7-14 provides a quick summary of passthrough and relay differences, which can also be viewed as advantages and disadvantages of each.

The information in Table 7-14 should be used by matching up the fax transport requirements for a particular network design with the strengths and weaknesses of fax passthrough and relay. For example, if the main design requirements are that fax calls must be transported across IP in a secure manner at SG3 speeds, modem passthrough is the option that should be chosen. However, if the design requirements change and only SRTP is mandatory, fax pass-through and Cisco fax relay now also become viable options along with modem passthrough.

Years ago, Cisco fax relay and passthrough were the dominant solutions for transporting fax over IP. However, it is worth noting that recent trends show that more networks are implementing T.38 fax relay. This is occurring primarily because T.38 is standards based and offers flexibility in integrating third-party gateways and fax servers.

In addition, T.38 has a robust redundancy feature and recent updates to the standard have added RTP encapsulation and SG3 support. Although widespread adoption of these recent T.38 features has not yet occurred, selecting T.38 fax relay as a transport option now ensures an easy migration to updated versions in the future. If multiple fax transport options, including T.38 fax relay, are viable for a particular network design, T.38 fax relay is the recommended choice.

**Table 7-14** *Differences Between Fax Passthrough and Fax Relay*

Attribute or Feature	Passthrough	Relay
Bandwidth	Utilizes full G.711 codec bandwidth. Modest reductions can be made with CRTP.	Consumes at least half the amount of bandwidth of a fax passthrough call.
Redundancy	Protocol-based fax pass-through does not support redundancy. NSE-based modem passthrough supports one level of redundancy via RFC 2198.	T.38 fax relay supports multiple layers of redundancy with separate settings for the low-speed and high-speed messages. Cisco fax relay does not support redundancy.

*continues*

**Table 7-14** *Differences Between Fax Passthrough and Fax Relay (Continued)*

<b>Attribute or Feature</b>	<b>Passthrough</b>	<b>Relay</b>
Protocol support	Only NSE-based modem passthrough is supported by all the voice signaling protocols. MGCP and SCCP do not support protocol-based fax pass-through.	Both T.38 and Cisco fax relay are supported by all the voice signaling protocols. However, SCCP can use only T.38 with an NSE-based switchover.
Product support	Modem passthrough is supported by all Cisco IOS gateways and non-IOS gateways, including the ATA, 6608/6624, and VG248. Fax pass-through is supported only on H.323 and SIP IOS gateways.	Cisco fax relay is supported by all Cisco IOS gateways (except for NextPort DSP platforms), and it is supported by all non-IOS gateways, except for the ATA. T.38 fax relay is supported by all IOS gateways along with the VG248.
Third-party interoperability	Third-party devices do not support modem passthrough because of its proprietary NSE-based switchover. Protocol-based fax pass-through should interoperate with most third-party gateways.	T.38 fax relay using a protocol-based switchover is the de facto standard for fax transport over IP. T.38 fax relay using an NSE-based switchover and Cisco fax relay are supported only by Cisco voice gateways. Both NSE-based T.38 fax relay and Cisco fax relay use proprietary switchovers, and the Cisco fax relay protocol itself is also proprietary.
Unified CM support	Protocol-based fax pass-through is not supported by Unified CM. Modem passthrough uses NSEs so that the switchover happens without Unified CM involvement.	Protocol-based T.38 is fully supported for H.323, SIP, and MGCP in Unified CM 6.0(1). NSE-based T.38 and Cisco fax relay use a switchover mechanism that does not involve Unified CM.
SG3 support	When configured for NSE-based modem passthrough, SG3 fax calls can negotiate at their native speeds. Protocol-based fax pass-through does not support SG3.	Relay does not support SG3, and fax machines must be forced down to G3 speeds to work with either T.38 or Cisco fax relay.
ECM disable	Passthrough calls have no control over ECM, and this is entirely left up to the fax machines.	Relay offers the ability for Cisco voice gateways to disable ECM. See the section “Error Correction Mode” in this chapter.

**Table 7-14** *Differences Between Fax Passthrough and Fax Relay (Continued)*

<b>Attribute or Feature</b>	<b>Passthrough</b>	<b>Relay</b>
Fallback support	Passthrough does not provide any fallback support to other transport options.	T.38 fax relay for H.323 and SIP provides multiple fallback options, including Cisco fax relay and protocol-based pass-through. Cisco fax relay does not support fallback.
SRTP and CRTP support	Passthrough can support CRTP for modest bandwidth savings and SRTP for secure faxing.	Because Cisco supports only T.38 with a UDPTL header, SRTP and CRTP are not possible with T.38 fax relay. Only Cisco fax relay can support CRTP and SRTP because it uses a standard RTP header.
DSP clock synchronization	In some instances where long faxes are occurring and significant DSP clock discrepancies exist, passthrough calls can experience problems. This issue is mitigated on the Telogy-based IOS gateways and was discussed previously in the section “Timing and Synchronization.”	This issue does not affect fax relay.

## Modem Design Considerations

Similar to fax, modem communications have the option of both passthrough and relay transport methods. The passthrough option for modems is simply named modem passthrough, and it shares this same syntax when it is configured on Cisco IOS gateways.

Modem passthrough is also applicable to fax calls and has already been discussed throughout the previous section, “Fax Design Considerations.” The technical intricacies of modem passthrough and its NSE-based switchover are discussed in the section “Modem Passthrough with NSE” in Chapter 4.

Two relay options are available on Cisco IOS voice gateways: Cisco modem relay and secure modem relay. Cisco modem relay provides an alternative transport method to modem passthrough for V.34 and V.90 modulated calls. Secure modem relay is designed for transporting the V.32 or V.34 modulation of secure telephones. Because of the unique application for the secure modem relay transport method, it is discussed separately in its own subsection.

## Comparing Modem Passthrough and Cisco Modem Relay

Of all the transport options available for fax and modem communications, modem passthrough enjoys the most widespread support among the Cisco voice gateways. All the Cisco IOS voice gateways support modem passthrough and all the non-IOS voice gateways. From a Cisco voice gateway interoperability standpoint, modem passthrough is always safe to use. However, when it comes to third-party voice gateway integration, the proprietary NSE-based switchover of modem passthrough is not supported by other vendors' products.

Cisco modem relay, on the other hand, is more restrictive. Because of the proprietary nature of the Cisco modem relay protocol and its NSE-based switchover, it is not supported by third-party gateways either. In addition, certain Cisco voice gateways, such as the 6608/6624, VG248, ATA, and any NextPort-based DSP gateway (5350, 5400, and 5850), also do not support Cisco modem relay. On Cisco voice gateways that do support modem relay, DSPs must use high complexity or flex mode. Compared to a modem passthrough call, a modem relay call consumes more DSP resources, as discussed previously in the section "Resource Utilization."

From a protocol interoperability perspective, both modem passthrough and Cisco modem relay work no matter what voice signaling protocol is used. As long as the voice gateway supports either feature, the voice signaling protocol does not matter. This is the main benefit of an NSE-based switchover, and it allows for modem passthrough and Cisco modem relay to be an effective transport method whether the voice signaling protocol is H.323, SIP, MGCP, or SCCP.

When deciding on whether to use modem passthrough or Cisco modem relay in a design situation, a number of factors concerning each of these transport methods should be studied. Table 7-15 summarizes some of the key differences between modem passthrough and Cisco modem relay.

If the design criteria for transporting modem traffic over IP has already been determined, Table 7-15 should assist in ascertaining the best choice. Both modem passthrough and Cisco modem relay have their advantages and disadvantages, but every network design is somewhat different.

In cases where both modem passthrough and Cisco modem relay are valid options, Cisco modem relay is the recommended transport option. Cisco modem relay is specifically engineered to transport modem communications over IP, whereas modem passthrough adapts a voice codec in an effort to accurately sample modulated data. Therefore, Cisco modem relay is more efficient and robust in maintaining successful modem over IP transmissions.

**Table 7-15** *Differences Between Modem Passthrough and Cisco Modem Relay*

<b>Attribute or Feature</b>	<b>Modem Passthrough</b>	<b>Cisco Modem Relay</b>
Bandwidth	Uses full G.711 codec bandwidth. Modest reductions can be made with CRTP.	Consumes less bandwidth than a modem passthrough call.
Redundancy	Supports 1 level of redundancy via RFC 2198.	Instead of redundancy, Cisco modem relay uses an error correction mechanism.
Modulation support	Works with any common modem modulation.	Only V.34 supported. V.90 calls will also work, but they are forced down to V.34 speeds.
Protocol support	Works with any voice signaling protocol because of NSE-based switchover.	Works with any voice signaling protocol because of NSE-based switchover.
Product support	Supported by all Cisco IOS and non-IOS voice gateways.	Only supported by Cisco IOS gateways, except for platforms using the NextPort DSP. In addition, more DSP resources are consumed compared to a modem passthrough call.
Third-party interoperability	Proprietary NSE switchover prevents third-party interoperability.	Proprietary transport protocol and NSE switchover prevent third-party interoperability.
Unified CM support	Not applicable because switchover occurs without Unified CM involvement.	Not applicable because switchover occurs without Unified CM involvement.
SRTP and CRTP support	Both SRTP and CRTP are supported.	Neither SRTP nor CRTP is supported, because of the usage of the SPRT protocol header.
DSP clock synchronization	A potential problem for extended modem calls, mainly on gateways not using Telogy-based DSPs. See the section "Timing and Synchronization."	This issue does not affect modem relay.

## Secure Modem Relay

Secure modem relay may also be referred to as “secure communication between STE endpoints.” This transport method is different from Cisco modem relay, and it is specifically designed for transporting the specific V.32 or V.34 modulations used by secure telephone devices. These devices pass encrypted voice using these modulations in an effort to prevent eavesdropping.

---

**NOTE** This section provides only a general overview of secure modem relay because of the unique, focused market segment that possesses a need for a feature such as this. For more detailed information about this transport method and its configuration and troubleshooting, refer to the online document “Secure Communication Between IP-STE Endpoint and Line-Side STE Endpoint” at Cisco.com.

---

The types of telephony devices that are supported by secure modem relay are known as secure terminal equipment (STE) endpoints. Line-side STE endpoints use a standard telephony connection such as an FXS or BRI port, whereas trunk-side STE endpoints support T1 and E1 interfaces. When an STE is connected directly to an IP network, it is known as an IP-STE endpoint. Third parties manufacture IP-STE endpoints compatible with Cisco modem relay, and they use a small SCCP stack and an abbreviated IP stack to connect to Unified CM.

---

**TIP** Another common type of secure endpoint is known as a secure telephone unit (STU). Using older technology, the STU is no longer produced and is being replaced by the STE. STU endpoints are not supported by secure modem relay, so any communications involving STUs must use modem passthrough as the transport method.

---

Secure modem relay requires Unified CM and is compatible only with the following voice gateways: 2800s, 3800s, and the VG224. These voice gateways must also be running the Cisco IOS Advanced Enterprise Services image (cXXXX-adventerprisek9-mz).

Secure modem relay voice gateways support only the MGCP and SCCP voice signaling protocols for interacting with Unified CM. When configured for MGCP, the voice gateway has a T1 connection to the PSTN and is referred to as a trunk-side gateway. Analog FXS and BRI connections use voice gateways with an SCCP connection back to Unified CM and are called line-side gateways. Figure 7-9 shows the components of a secure modem relay deployment and how they interoperate.

Figure 7-9 Secure Modem Relay Network Topology

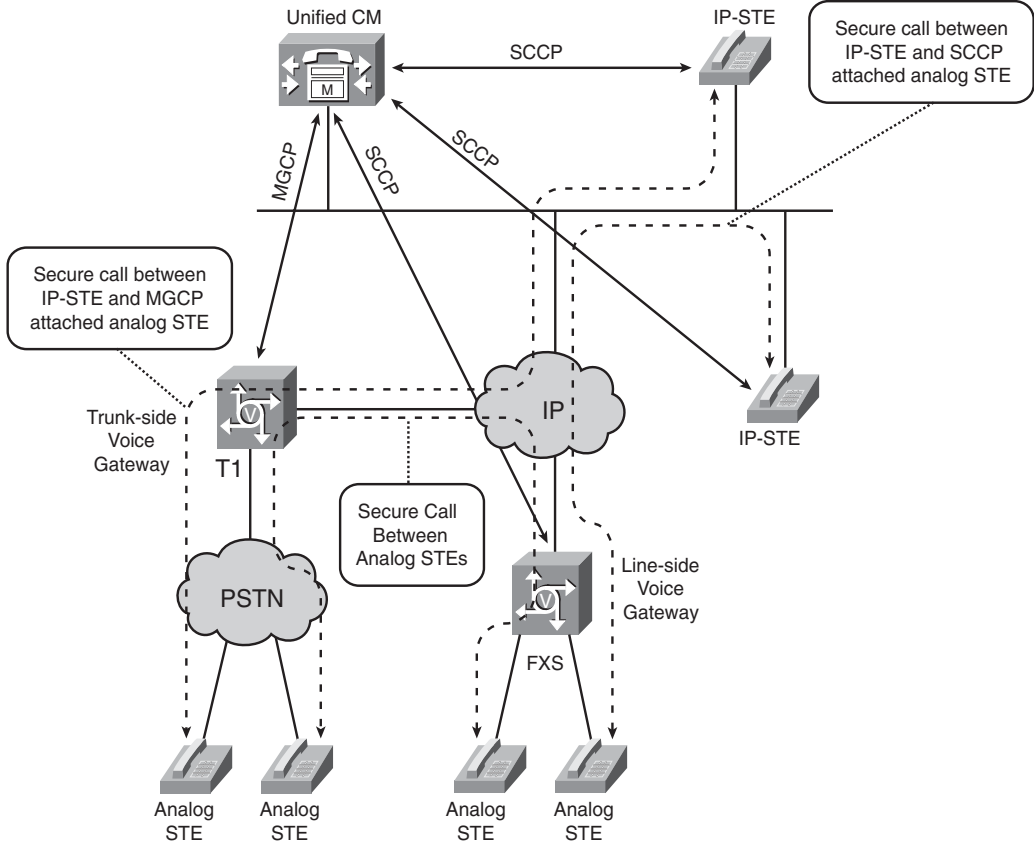

You can see in Figure 7-9 how the different STE devices interconnect with one another and Unified CM. No matter whether the endpoint is an IP-STE, an STE connected via a trunk-side voice gateway, or an STE connected via a line-side voice gateway, communication using secure modem relay is possible.

Secure modem relay is a feature that addresses a very specialized market segment where encrypted communications are necessary over an IP infrastructure. Although modem passthrough might work as an alternative to secure modem relay, it is not the best choice. If STE endpoints need to interoperate in a secure fashion over IP, secure modem relay is the recommended solution.

## Text Design Considerations

Text calls over IP can be transported in one of two ways by Cisco IOS voice gateways: text over G.711 or Cisco text relay. The text over G.711 method is a manual passthrough configuration that uses the G.711 codec to transport the text tones across the IP network. Cisco text relay is a proprietary transport method that passes text characters out of band using special RTP payload types.

Both text over G.711 and Cisco text relay and how they each work were covered in previous chapters. For more information about how these transport methods work, see the section “Text over G.711” in Chapter 4 and the section “Cisco Text Relay” in Chapter 5.

The text over G.711 transport method suffers from the disadvantages that affect both modem passthrough and fax pass-through. These disadvantages include large bandwidth consumption by the G.711 codec and sensitivity to packet loss. Referring back to Table 7-2, the G.711 codec uses more than 80 Kbps of bandwidth per call, and lab testing has shown that once packet loss exceeds 0.1 percent, you can start experiencing text character loss rates greater than 1 percent.

Cisco text relay, on the other hand, consumes very little bandwidth, typically less than 3 Kbps. Furthermore, with full redundancy enabled, Cisco text relay can transport 99.95 percent of text characters successfully, with 10 percent packet loss.

Cisco text relay was introduced on select Cisco IOS voice gateways using C5510 DSPs, such as the 2800 and 3800 series, in IOS Version 12.4(6)T. Because Cisco text relay does not use a switchover mechanism like fax or modem relay, it can interoperate easily in any VoIP network, including Unified CM environments. The Cisco voice gateways just pass a text character out of band as it would a DTMF digit using DTMF relay. If a VoIP call can be established between Cisco voice gateways using the H.323, SIP, MGCP, or SCCP voice signaling protocols, Cisco text relay is a seamless addition.

---

**TIP**

Although a number of different text phone protocols are in use around the world, Cisco text relay currently supports only the text protocols of Baudot 45.45 bps and Baudot 50 bps.

---

The disadvantage of Cisco text relay is that the only Cisco products supporting this feature are certain IOS voice gateways. Therefore, one of these Cisco IOS voice gateways must originate and terminate a Cisco text relay session. For all other text connections over IP, text over G.711 must be used. Figure 7-10 illustrates a network where text over G.711 and Cisco text relay are implemented concurrently to support a variety of text over IP communications.

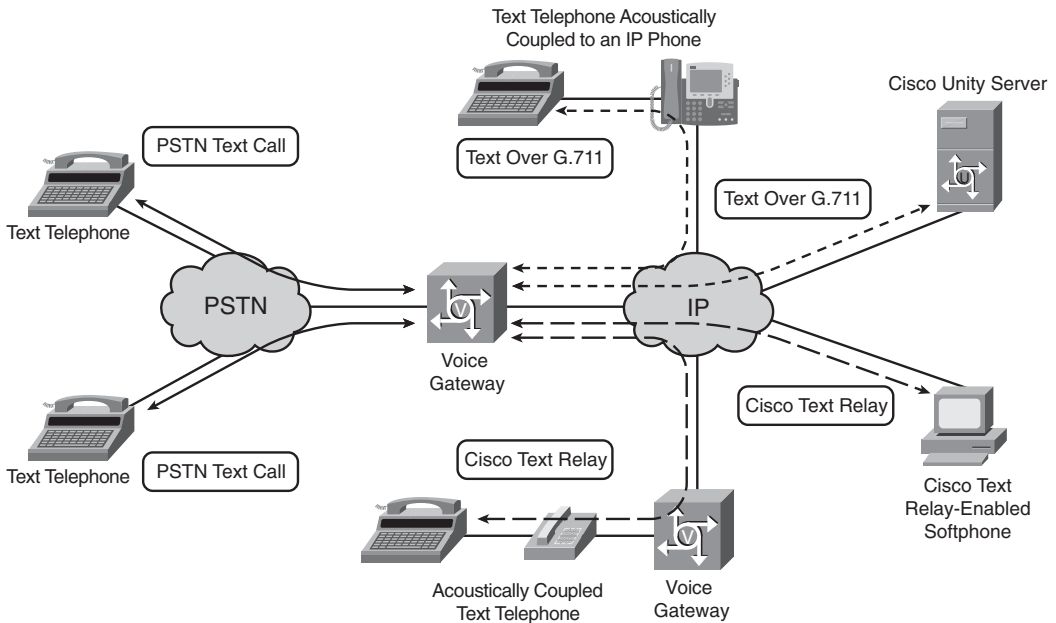
**Figure 7-10** Transporting Text Using Text over G.711 and Cisco Text Relay

On the left side of Figure 7-10, text telephones are connected via the PSTN to a Cisco voice gateway. This Cisco voice gateway interconnects the PSTN text telephones to text devices on the IP network using either text over G.711 or Cisco text relay.

Specific dial peers on the voice gateway determine whether text over G.711 or Cisco text relay should be used. For connections to text telephones acoustically coupled to IP phones or connections to a Cisco Unity server, configure text over G.711 under the corresponding dial peer. For text connections to other Cisco voice gateways or supported third-party softphones, configure Cisco text relay under the dial peer as the transport method.

**TIP**

Third-party softphones, such as the VTGO Advanced by IP blue, feature built-in Cisco text relay support. Because this tty device has a full integration of the Cisco text relay protocol, it can communicate directly to Cisco voice gateways without the need for using the less-efficient text over G.711 transport method.

In Figure 7-10, notice an example of a text telephone being acoustically coupled to a standard telephone and an IP phone. Although this might be the only option in many cases, you should ideally strive to have direct connections to the PSTN or IP network. Creating an

acoustically coupled connection that is free of external, ambient noise can sometimes be difficult. This ambient noise can corrupt text characters and contribute to unreliable text communications.

The Cisco Unity server as shown in Figure 7-10 can integrate directly with text over G.711 from a voice-mail perspective. Using the Unity TTY WAV Maker tool, a user can type a message and then have this message translated into a WAV file that Unity can play to text telephones. The WAV file consists of standard Baudot tones, and these appear as characters on the text telephone when the file is played. One of the applications here is that text-telephone-accessible voice mails can be created for the appropriate users to retrieve.

Another Cisco Unity tool is the TTY WAV Reader. This tool performs the opposite function of the TTY WAV Maker. If a hearing- or speech-impaired user leaves a voice mail using a text telephone, the TTY WAV Reader tool pulls the Baudot tones from the voice-mail message and outputs the correlating text characters. With the TTY WAV Reader tool, voice-mail messages from text telephone users can be interpreted by anyone.

Both the TTY WAV Maker and the TTY WAV Reader tools are available for download from the CiscoUnityTools.com website. Also included on this site is the TTY Angel tool, which is similar to the TTY WAV Maker tool but includes additional features. The specific URLs for downloading these tools are as follows:

[http://www.ciscounitytools.com/App\\_TTYWAVMaker.htm](http://www.ciscounitytools.com/App_TTYWAVMaker.htm)  
[http://www.ciscounitytools.com/App\\_TTYWAVReader.htm](http://www.ciscounitytools.com/App_TTYWAVReader.htm)  
[http://www.ciscounitytools.com/App\\_TTYAngel.htm](http://www.ciscounitytools.com/App_TTYAngel.htm)

Implementing any of these Unity TTY tools or providing connections to text phones that are acoustically coupled to IP phones requires that text over G.711 be implemented. Although this is not the most efficient or reliable choice, it is the only choice when planning for these devices. Otherwise, from a best practices standpoint, Cisco text relay should be used whenever possible for transporting text communications over IP.

## Summary and Best Practices

Although design information for basic VoIP networks is not hard to find, applying VoIP-specific design information to modulated communications rarely works. Planning for modulated communications such as fax, modem, and text communications in IP networks requires focused design information tailored to these technologies.

This chapter provided the necessary design information required for implementing fax, modem, and text communications over IP. Organized into four distinct sections, a number of best practices were presented in each of these sections.

The first section discussed some general design considerations for passthrough and relay that are applicable whether faxes, modems, or text communications are being transported. The best practices covered in this first section include the following:

- Relay utilizes less bandwidth than passthrough. If bandwidth is a concern, always choose a relay transport method if possible.
- The H.323 and SIP call control protocols provide more options and flexibility for fax, modem, and text traffic compared to SCCP and MGCP.
- Packet loss is more harmful to a fax, modem, or text call than a voice call, so QoS is necessary. If you have already implemented a good QoS policy that prioritizes voice throughout the network, this is almost always adequate for fax, modem, and text communications, too.
- If any packet loss exists for fax, modem, or text traffic in your network, redundancy should be enabled.
- The C5510 DSP can be oversubscribed in flex-complexity mode. This can pose potential problems if fax relay, T.37, and modem relay are not properly planned for.
- Maintaining a correct clocking relationship that is free of errors on a voice gateway's digital interfaces is critical. In rare circumstances, timing disparities between DSPs can cause passthrough calls of a long duration to fail. Plan on using a relay transport method if fax or modem calls will need to be connected for long periods of time.

The next section discussed fax design considerations. Numerous transport methods are available when dealing with fax communications, so some of the best practices from this section are relevant only to a particular transport method. The best practices from this section are as follows:

- Cisco IOS voice gateways based on the Telogy DSP platform, such as C5510, offer the most versatility in transporting fax communications and should be selected when possible.
- T.38 fax relay is usually the best transport method for fax communications, especially when interoperability with third-party fax devices is necessary.
- Cisco voice gateways can disable ECM. The ECM option negotiated by the fax endpoints should not be disabled by the Cisco voice gateway unless you are willing to trade a higher call success rate for image quality.
- You should have a plan for dealing with SG3 fax transmissions. The two most popular methods are using modem passthrough or the IOS feature Fax Relay Support for SG3 Fax Machines at G3 Speeds.
- In situations where it is necessary for a fax hairpin call, you should aim for a TDM hairpin, where the DSP drops out of the call for best results.

- If T.38 fax relay is selected as your fax transport protocol, an NSE-based switchover or a protocol-based switchover for T.38 should be selected and implemented throughout the network. However, in cases where this is not possible, T.38 fallback can provide interoperability assistance between NSE-based T.38, protocol-based T.38, Cisco fax relay, and pass-through.
- T.37 store-and-forward fax is a transport option that uses a fax to/from e-mail conversion process rather than a real-time transport method such as passthrough or relay. In some situations, T.37 may be preferred over fax passthrough or relay.
- For the best T.38 fax relay integration with Unified CM, software Release 6.0(1) or later is recommended.

Modem design considerations were discussed next in this chapter. This section highlighted the modem transport methods of modem passthrough, Cisco modem relay, and secure modem relay. The best practices transporting modem traffic over IP consist of the following:

- Implement Cisco modem relay over modem passthrough if possible because of its improved efficiency and reliability.
- Secure modem relay is the best option for transporting secure communications based on STE endpoints.

The last section of this chapter covered text design considerations and its transport methods of text over G.711 and Cisco text relay. The best practices to take away from this section include the following:

- Implement Cisco text relay whenever possible even though it is a proprietary implementation that works only between select Cisco IOS gateways and select third-party softphones.
- If various text endpoints require a mixture of text over G.711 and Cisco text relay communications, use separate dial peers on the Cisco voice gateway to route calls with the necessary transport method to the appropriate text device.

The best practices and design information presented in this chapter provide you with the knowledge to properly plan for the integration of fax, modem, and text devices into an IP environment. Prudent application of the design principles in this chapter is essential to prevent problems and redesigns down the road.

# INDEX

## Symbols

---

“push” protocols, 192

## Numerics

---

6 set mask0x323 command, 462–464  
6 show call command (Dick Tracy), 419–423, 481  
6608 line card configuring passthrough, 295–298

## A

---

abbreviations (text telephone communication), 116–117  
accessing fax servers, 267  
acoustic coupling, 113  
acronyms (text telephone communication), 116–117  
adaptive Huffman encoding, 48  
ADP (Answer Detection Pattern), 47  
advanced troubleshooting  
Cisco text relay, 506–510  
fax relay, 487  
    *high delay*, 500, 502  
    *NSF/NSS messages*, 499–500  
    *packet loss*, 488, 490  
    *Super G3*, 490–491  
    *T.30 fax messaging*, 491–496  
modem relay, 503–506  
passthrough, 485–486  
AFE (analog front end), 9  
Americans with Disabilities Act, 107  
    TRS, 118–119  
amplitude, 27  
analog modem architecture, 8–9  
analyzing  
    PCM traces, 510, 515  
    *of fax calls*, 516–519  
    *of modem calls*, 520–522  
    T.38 packet captures, 497–499  
APIs, accessing fax servers, 267  
application command, 353  
ASK (Amplitude Shift Keying), 30  
asynchronous framing, 19–20  
AT interface, 21–25

## B

---

bandwidth considerations for VoIP networks with fax, modem and text capability, 209–214  
basic troubleshooting checks, performing, 383–385

debugging best practices, 387–391  
verifying configuration, 386–387

baud rate, 27

Baudot text protocol, 107, 121

character set, 121, 123  
EIA-TIA-825-A specification, FSK, 123–124  
shift synchronization, 123

Baudot, Emile, 121

## C

---

C5510 DSP

complexity mode, 225  
flex-complexity mode, 226

CAC (Call Admission Control), managing

bandwidth consumption on VoIP networks, 213

CA-controlled T.38 fax relay, 321

call analysis, 34

call setup, 35–42  
data mode, 42, 45  
    *call disconnect*, 49  
    *data compression*, 48–49  
    *error control*, 45–48

ECM fax calls, 82–84

call analysis (fax)

CED tone, 67  
CFR messages, 73  
CNG tone, 66  
CSI messages, 70  
DCN messages, 76  
DCS messages, 71–72  
DIS messages, 68  
EOM messages, 75  
EOP messages, 75  
FTT messages, 73  
MCF messages, 76  
MPS messages, 75  
NSF messages, 69  
RTN messages, 76  
RTP messages, 76  
TCF messages, 73  
TSI messages, 71–72

call control protocol considerations for VoIP networks with fax, modem and text capability, 214–215

call disconnect, 49

call legs, 392–393

Cisco modem relay call legs, viewing, 402–404  
fax passthrough call legs, viewing, 399–400  
fax relay call legs, viewing, 400–402

- modem passthrough call legs, viewing, 394–399
- text telephony call legs, viewing, 404–405
- troubleshooting, 405–407
- viewing, 394
- call setup, 35, 37–40, 42**
- capabilities of fax servers, 267–268**
- CapTel, 119**
- capturing PCM traces, 511–515**
- carrier signal, 27**
- carrier-based text telephone protocols, 111–112**
- carrierless text telephone protocols, 111–112**
- Catalyst 6608 gateways, configuring Cisco fax relay, 342–344**
- Catalyst switches, configuring passthrough on 6608 line card, 295–298**
- CCAPI (Call Control Application Programming Interface ), 465**
- ccm-manager fax protocol cisco command, 324**
- CED tone, 67**
- CFR (confirmation) messages, 73**
- Cisco ATA (Analog Telephone Adapter), configuring passthrough, 303–308**
- Cisco fax relay, 173–175**
  - bandwidth consumption, 213
  - configuring
    - on Catalyst 6608, 342–344*
    - for H.323, 336–337*
    - for SIP, 336–337*
  - switchover, troubleshooting, 461–464
- Cisco Fax Server, 264**
- Cisco IOS gateways**
  - call legs, 392–393
    - troubleshooting, 405–407*
    - viewing, 394–405*
  - fax relay, configuring, 312–314, 318–325
  - IP, troubleshooting, 416–419
  - relay, configuring, 311
- Cisco modem relay**
  - call legs, viewing, 402–404
  - configuring for H.323, SIP, and SCCP, 326–328, 337–339
  - configuring for MGCP, 329–331
  - HPI debugs, 472–477
  - NSE-based switchover, troubleshooting, 434–436
  - termination codes, 476
- Cisco PCM capture tool, 512–514**
- Cisco text relay, 181–184, 256, 258**
  - advanced troubleshooting, 506–510
  - bandwidth consumption, 213
  - configuring, 332–333
    - for H.323 and SIP, 337–339*
    - for SCCP, 339–340*
- Cisco Unity TTY tools, 258**
- cleardown, 49**
- clock slips, troubleshooting, 408**
- CM (Calling Menu) messages, 37**
- CNG tone, 66**
- CNG tone detection, 244–245**
- codec upspeed, 137**
- codecs, 131**
  - text over G.711, 146–147
- commands, 507**
  - application, 353
  - ccm-manager fax protocol cisco, 324
  - debug, displaying output, 388
  - debug ccsip messages, 441, 451–454
  - debug fax dmsp, 553–556
  - debug fax dsmp, 537–538
  - debug fax fmsp send t30, 557–559
  - debug fax foip detail, 529–532, 547–548
  - debug fax fsmsp, troubleshooting T.37 onramp, 533–535
  - debug fax mspi, 544–545, 551–552
  - debug fax mta, 549–550
  - debug fax mta detail, 540–542
  - debug fax relay t30 all-level-1, 491–501, 556–557
  - debug h245 asn1, 448–451
  - debug h245 events, 446–447
  - debug mgcp packets, 442, 455–459
  - debug mmoip send fax, 559
  - debug voip hpi, 467, 470–472
  - debug voip rtp session named-event, 430–438, 461
  - debug voip rtp session text-relay, 509
  - Dick Tracy
    - 6 set mask 0x323, 462–464*
    - 6 show call, 419–423, 481*
  - ESMTP, 194
  - fax interface-type fax-mail, 351
  - fax nsf, 319
  - fax protocol, 294, 318
  - fax protocol pass-through, 143
  - fax protocol t38, 318
  - fax rate, 315
  - fax receive called-subscriber, configuring T.37 onramp, 360
  - fax-relay, 320
  - h245 asn1, 440–441
  - image encoding, 359
  - image resolution, 359
  - logging monitor, 388

mgcp default-package fxr-package, 325  
 mgcp fax rate, 323–325  
 mgcp fax t38, 322–325  
 mgcp fax-relay sg3-to-g3, 324–325  
 mgcp modem passthrough voip, 293  
 mgcp modem relay voip gateway-xid, 329  
 mgcp modem relay voip latency, 331  
 mgcp modem relay voip mode nse, 329  
 modem passthrough nse, 143, 289  
 modem relay gateway-xid, 328  
 modem relay latency, 328  
 modem relay nse, 327–328  
 mta send success-fax-only command, 540  
 service, 353–355  
 show call active voice brief, 394–405  
 show call active voice brief id, 406–407  
 show call history voice brief, 405–406  
 show controllers t1, 408–410  
 show dial-peer voice, 218  
 show logging, 389  
 show memory summary, 388  
 show modem relay statistics pkt, 506  
 show port voice fdl, 413  
 show voice call, 416–419  
 show voice hpi capture, 514  
 SMTP, 193–194  
 terminal monitor, 388  
 text relay modulation, 333  
 text relay protocol, 332  
 text relay rtp, 333  
 voice service voip, 288, 314

### companding, 131–132

### comparing

modem passthrough and Cisco modem relay, 252  
 passthrough and relay, 249–250  
 relay and passthrough, 151–153

### complexity mode (C5510 DSP), 225

### configuring

Cisco fax relay on Catalyst 6608 gateway,  
 342–344  
 Cisco modem relay  
   for *H.323, SIP, and SCCP*, 326–328  
   for *MGCP*, 329–331  
 Cisco text relay, 332–333  
   for *SCCP*, 339–340  
 Cisco voice gateways for T.38 fax server  
 communication, 275–276  
 fax relay on Cisco IOS gateways, 312  
   *H.323, SIP, and SCCP*, 313–314, 318–320  
   *MGCP*, 320–325  
   *VG 248 gateways*, 344–347  
 MCGP, 340–342

passthrough, 287  
   *IOS passthrough*, 288  
   *NSE-based*, 289–293  
   on 6608 line card, 295–298  
   on Cisco ATA, 303–308  
   on VG248, 298–303  
   protocol-based, 293–294  
   text over G.711, 295  
 relay on Cisco IOS gateways, 311  
 T.37 offramp, 367  
   *dial peers*, 367–368  
   *fax send parameters*, 369–371  
   *MTA*, 372–373  
   *sample configuration*, 373–375  
 T.37 onramp, 354–355  
   *dial peers*, 355–360  
   *fax receive called-subscriber command*,  
   360  
   *MTA*, 361–365  
   *sample configuration*, 365–366  
 T.37 store-and-forward fax  
   *TCL scripts, loading*, 352–353  
 T.38 fax relay  
   for *MGCP*, 340–342  
   for *SCCP*, 339–340

### connectivity, testing, 384–385

### controller, 9

### controllerless modems, 11

### conversation conventions for text telephone communication, 116–117

### CRC (cyclic redundancy check), 64

### CRPT (Compressed Real-Time Transport Protocol), effect on bandwidth consumption, 210

### CSI (called subscriber identification) messages, 70

## D

### DAA (data access arrangement), 9

### data compression, 48–49

### data mode, 42, 45

data compression, 48–49  
 error control, 45–48

### data pump, 9

### DCE (data circuit-terminating equipment), 15

### DCN (disconnect) messages, 76

### DCS (digital command signal) messages, 71–72

### DCS\_PACKET parameters, 536

### debug ccsip messages command, 441, 451–454

### debug commands, displaying output, 388

### debug fax dmosp command, 537–538, 553–556

### debug fax fmsp send t30 command, 557–559

### debug fax foip detail command, 529–532, 547– 548

**debug fax fsm command, troubleshooting T.37 onramp, 533–534**

**debug fax fsm t30 command, troubleshooting T.37 onramp, 535**

**debug fax mspi command, 544–552**

**debug fax mta command, 549–550**

**debug fax mta detail command, 540–542**

**debug fax relay t30 all-level-1 command, 491–501, 556–557**

**debug h245 asn1 command, 440–441, 448–451**

**debug h245 events command, 446–447**

**debug message timestamps, setting, 390**

**debug mgcp packets command, 442, 455–459**

**debug mmoip send fax command, 559**

**debug voip hpi command, 467, 470–472**

**debug voip hpi notification, 507**

**debug voip hpi notification command, 507**

**debug voip rtp session named-event command, 430–438, 461**

**debug voip rtp session text-relay command, 509**

**debugging**

- best practices, 387–391
- modem relay, 505–506

**default fax relay configuration**

- for H.323, 334–335
- for SIP, 334–335

**delay, 216**

**designing VoIP networks for fax, modem and text capability**

- bandwidth considerations, 209–214
- call control protocol considerations, 214–215
- ECM considerations, 233–235
- fallback considerations, 239–241
- fax detect script considerations, 243–245
- gateway interoperability considerations, 231–233
- hairpin call considerations, 237–239
- QoS considerations, 215, 217–218
  - dial peer configuration, 218*
  - LLQ configuration, 219–221*
- redundancy considerations, 221–223
- resource utilization considerations, 224, 226–227
- SRTP considerations, 227–228
- Super G3 considerations, 235–237
- T.37 considerations, 241–243
- timing/synchronization considerations, 229–231

**dial peers, 392**

- call legs, 392–393
  - troubleshooting, 405–407*
  - viewing, 394–405*
- configuring
  - for T.37 offramp, 367–368*

- for T.37 onramp, 355–358, 360*

**Dick Tracy utility, 411**

- 6 show call command, 419–423
- digital interfaces, troubleshooting, 411

**digital interfaces, troubleshooting, 407–413**

**direct connection text telephones, 114**

**DIS (digital identification signal) messages, 68**

**DIS\_PACKET parameters, 536**

**displaying**

- debug command output, 388
- processor memory information, 388

**Disposition field (MDN messages), 200–201**

**dpi (dots per inch), 91**

**DPSK (Differential PSK), 30**

**DSN (delivery status notification) messages, 195**

- configuring for MMoIP dial peers, 359
- NOTIFY parameter, 196–197
- successful delivery message, 197–198

**DSPs (digital signal processors), 9, 153**

- C5510 DSP, 224
  - complexity mode, 225*
  - flex-complexity mode, 226*
- HPI, troubleshooting, 465–478

**DTE (data terminal equipment), 15**

**dynamic payload types, 136**

## E

**EC (error correction) protocols, 178**

- V.42, 179

**ECM (Error Correction Mode), 81–82, 488**

- call analysis, 82, 84
- PPR messages, 84–86
- PPS messages, 84–86

**ECM considerations for VoIP networks with fax, modem and text capability, 233–235**

**EHLO command, 193**

**EIA-TIA-825-A specification, FSK, 123–124**

**enabling T.37 store-and-forward fax, 351**

**encoding schemes, 59, 92**

- MH, 92–96
- MMR, 103–104
- MR, 97, 100–103

**endpoints, secure modem relay, 254–255**

**ENVID parameter (DSN messages), 197**

**EOM (end of message) messages, 75**

**EOP (end of procedure) messages, 75**

**error control, 45–48**

**ESMTP (Extended Simple Mail Transfer Protocol), 193**

- commands, 194
- DSN messages, 196

**Event IDs (NSE-based passthrough), 139**  
**external modems, 10**  
**extracting PCM from packet captures, 514–515**

## F

**fallback considerations for VoIP networks with fax, modem and text capability, 239–241**

### fax

- call analysis, 65
  - CED tone, 67*
  - CFR messages, 73*
  - CNG tone, 66*
  - CSI messages, 70*
  - DCN messages, 76*
  - DCS messages, 71–72*
  - DIS messages, 68*
  - EOM messages, 75*
  - EOP messages, 75*
  - FTT messages, 73*
  - MCF messages, 76*
  - MPS messages, 75*
  - NSF messages, 69*
  - RTN messages, 76*
  - RTP messages, 76*
  - TCF messages, 73*
  - TSI messages, 71–72*
- ECM, 81–82
  - call analysis, 82–84*
  - PPR messages, 84–86*
  - PPS messages, 84–86*
- encoding schemes, 59, 92
  - MH, 92–96*
  - MMR, 103–104*
  - MR, 97, 100–103*
- G3, protocol timers, 86–87
- group classifications, Super G3, 88–89
- history of, 54, 56
- ITU-T fax group classifications, 57–58
- modulation schemes, 59–61
- scan lines, 91
- T.4 specification, 58
- T.30 specification, 58
  - call phases, 62–63*
  - messages, 63–64, 77–81*

### fax boards, 264

### fax calls, analyzing PCM traces, 516, 518–519

### fax capability, implementing in VoIP networks

- ECM considerations, 233–235
- fallback considerations, 239–241
- fax detect script considerations, 243–245

- gateway interoperability considerations, 231–233
- hairpin call considerations, 237–239
- Super G3 considerations, 235–237
- T.37 considerations, 241–243

### fax classes, 12

### fax detect script considerations for VoIP networks with fax capability, 243–245

### fax interface-type fax-mail command, 351

### fax messaging, 61

### Fax mode (Cisco ATA), 304

### fax modems, 12–14

### fax nsf command, 319

### fax page image creation, troubleshooting for T.37 offramp, 553–556

### fax passthrough, 139–144

- call legs, viewing, 399–400
- with H.323 signaling, 144
- with NSE, 139–141
- with protocol-based passthrough, 143–144
- with SIP signaling, 145

### Fax passthrough mode (Cisco ATA), 304

### fax protocol command, 294, 318

### fax protocol pass-through command, 143

### fax protocol t38 command, 318

### fax rate command, 315

### fax receive called-subscriber command, configuring T.37 onramp, 360

### fax relay, 153–154

- advanced troubleshooting, 487
- call legs, viewing, 400–402
- calls, bandwidth consumption, 212
- Cisco fax relay, 173–175
  - configuring on Catalyst 6608 gateway, 342–344*
- configuring
  - on Cisco IOS gateways, 312–325
  - for H.323, 334–335
  - for SIP, 334–335
  - on VG248 gateway, 344–347
- data rate, troubleshooting, 487
- high delay, advanced troubleshooting, 500–502
- NSF/NSS messages, advanced troubleshooting, 499–500
- packet loss, advanced troubleshooting, 488–490
- Super G3, advanced troubleshooting, 490–491
- T.30 fax messaging, advanced troubleshooting, 491–496
- T.38, 155

- configuring, 337–339*

- fax call flow, 163–167*

- NSE-based switchover, 167–169*

*protocol-based switchover, 169–173*

*T.30\_DATA packets, 158–161*

*T.30\_INDICATOR packets, 156–158*

**fax send parameters, configuring for T.37 offramp, 369–371**

**fax servers, 263–264**

accessing, 267

capabilities, 267–268

drop and insert, 270

failover, 281–282

hardware-based, 264–266

integrating with Cisco products, 269

redundancy, 281–282

software-based, 264–266

T.38 integration with Cisco voice gateway, 272–276

T.38 integration with CUCM, 276–281

TDM integration with Cisco voice gateway, 269–271

**fax-relay command, 320**

**FCD (fax coded data), 84**

**FEC (Forward Error Correction), 32**

**flex-complexity mode (C5510 DSP), 226**

**FSK (Frequency Shift Keying), 28, 60, 123–124**

**FTT (failure to train) messages, 73**

## G

**G.711 codecs, 131**

companding, 132

text over G.711, 146–147

**G3 classification**

fax calls, bandwidth consumption, 212

modulation schemes, 60

protocol timers, 86–87

**GA (go ahead), 116**

**gateway**

**gateway interoperability considerations for VoIP networks with fax, modem and text capability, 231–233**

**gateways**

Cisco IOS, troubleshooting IP, 416–419

fax relay, 154

*Cisco fax relay, 173–175*

*T.38, 155–156, 167–173*

non-IOS, troubleshooting IP, 419–423

verifying configuration, 386–387

VG248, configuring fax relay, 344–347

**global passthrough, configuring, 288**

**Gray, Elisha, 55**

**group classifications, 57–58**

Super G3, 88–89

## H

**H.323**

Cisco modem relay, configuring, 326–328, 337–339

Cisco text relay, configuring, 337–339

fax relay

*configuring on Cisco IOS gateways, 313–314, 318–320*

*default configuration, 334–335*

modem passthrough, configuring, 336–337

NSE-based passthrough, configuring, 289–291

passthrough, 144

protocol-based switchover, troubleshooting, 446–451

T.38 fax relay, configuring, 337–339

**hairpin call considerations for VoIP networks with fax, modem and text capability, 237–239**

**hardware modems, 11**

**hardware-based fax servers, 264–266**

**Hayes command set, 6**

**HCO (hearing carry over), 119**

**HDLC (High-Level Data Link Control) frame format, 64**

**HELO command (SMTP), 193**

**high delay on fax relay, troubleshooting, 500–502**

**history of fax, 54–56**

**history of modems, 5**

56K protocol, 8

Hayes command set, 6

V.92 standard, 8

**history of text telephony, 107–109**

**HPI communications, troubleshooting, 465–478**

**HSP (host signal processor) modems, 11**

## I

**IFPs (Internet Fax Packets), 156**

T30\_DATA packets, 158–161

T30\_INDICATOR packets, 157–158

**image encoding command, 359**

**image resolution command, 359**

**integrating fax servers with Cisco products, 269**

T.38 integration with Cisco voice gateway, 272–276

T.38 integration with CUCM, 276–281

TDM integration with Cisco voice gateway, 269–271

**internal modems, 10**

**interpreting PCM traces, 510, 515**

of fax calls, 516–519

of modem calls, 520–522

**IOS passthrough, configuring, 288**

**IP relay, 119**

**IP/telephone troubleshooting, 407–414**

call legs, 392–393, 405–407

viewing, 394–405

for Cisco IOS gateways, 416–419

for non-IOS gateways, 419–423

packet captures, 424–428

**ITU-T, 112**

**ITU-T fax group classifications, 57–58**

**ITU-T Recommendation T.37, 189**

**ITU-T V.152, 147–148**

**ITU-T V.18 specification website, 121**

## J-K-L

**jitter, 216**

**Korn, Arthur, 55**

**LAPM (Link Access Procedure for Modems), 46**

**legislation, Americans with Disabilities Act, 107**

TRS, 118–119

**line probing, 38**

**loading TCL scripts, 352–353**

**logging monitor command, 388**

**loss, 216**

**loss planning, 478–485**

**LSB (Least Significant Bit), 124**

## M

**manually replicating SMTP sessions, 553**

**Marsters, James C., 109**

**MCF (message confirmation) messages, 76**

**MDN (message disposition notification) messages, 198–200**

configuring for MMoIP dial peers, 359

Disposition field, 200–201

Notification field, 201

**messages**

T.30, 77–81

T.30 fax, 63–64

**MFD (Multi Function Device), 267**

**MFP (Multi Function Printer/Product/Peripheral), 267**

**MGCP (Media Gateway Control Protocol)**

Cisco modem relay, configuring, 329–331

fax relay, configuring on Cisco IOS gateways, 320–325

modem passthrough, configuring, 340–342

NSE-based passthrough, configuring, 292–293

protocol-based T.38 switchover,

troubleshooting, 455–459

T.38 fax relay, configuring, 340–342

**mgcp default-package fxr-package command, 325**

**mgcp fax rate command, 323**

**mgcp fax t38 command, 322–325**

**mgcp fax-relay sg3-to-g3 command, 324–325**

**mgcp modem passthrough voip command, 293**

**mgcp modem relay voip gateway-xid command, 329**

**mgcp modem relay voip latency command, 331**

**mgcp modem relay voip mode nse command, 329**

**MH (Modified Huffman) encoding, 59, 92–96**

**MIME (Multipurpose Internet Mail Extension), 190**

**MMoIP dial peers, configuring**

for T.37 offramp, 367–368

for T.37 onramp, 355–360

**MMR (Modified Modified READ) encoding,**

**59, 92, 103–104**

**modem architecture, 8–9**

**modem passthrough, 141–143**

call legs, viewing, 394–399

comparing with Cisco modem relay, 252

configuring

for H.323, 336–337

for MGCP, 340–342

for SIP, 336–337

NSE-based switchover, troubleshooting, 430–434

with NSE, 141–143

**modem passthrough nse command, 143, 289**

**modem relay, 175–176**

advanced troubleshooting, 503–506

Cisco modem relay

configuring for H.323 and SIP, 337–339

configuring for H.323, SIP, and SCCP,

326–328

configuring for MGCP, 329–331

debugging, 505–506

EC protocols, 178–179

NSE messages, 179–181

**modem relay gateway-xid command, 328**

**modem relay latency command, 328**

**modem relay nse command, 327–328**

**modems**

AT interface, 21–25

call analysis, 34, 520–522

call disconnect, 49

call setup, 35–42

data mode, 42, 45–49

endpoints, verifying, 503–505

- fax modems, 12–14
- hardware modems, 11
- history of, 5
  - 56K protocol*, 8
  - Hayes command set*, 6
  - V.92 standard*, 8
- software modems, 10–11
- terminal to modem communication
  - asynchronous framing*, 19–20
  - DTE/DCE*, 15
  - RS-232 signaling*, 15–18
  - user interface*, 20–25

**modulation, 26–27**

- AM, 30
- fax modulation schemes, 59–61
- FSK, 28
- PSK, 29–30
- QAM, 31
- standards, 33–34
- TCM, 32

**MPS (multipage signal) messages, 75****MR (Modified READ) encoding, 59, 92, 97, 100–103****MSLT (minimum scan line time), 96****MTA (mail transfer agent), 192**

- configuring for T.37 offramp, 372–373
- configuring for T.37 onramp, 361–365

**mta send success-fax-only command, 540****N****non-IOS gateways, troubleshooting IP problems, 419–423****Notification field (MDN messages), 201****NOTIFY parameter (DSN messages), 196–197****NSE messages, 179–181****NSE-based passthrough, 137–143**

- configuring, 289–293
- Event IDs, 139

**NSE-based switchover**

- for Cisco modem relay, troubleshooting, 434–436
- for modem passthrough, troubleshooting, 430–434
- for T.38 fax relay, 167–169, troubleshooting, 436–438
- validating, 438–445

**NSE-based T.38 fax switchover with CUCM, 245–247****NSF (nonstandard facilities) messages, 69****NSF/NSS messages, troubleshooting fax relay, 499–500****O****offramp gateways, 203–204****offramp mode (T.37), 190****offramp SMTP connection, troubleshooting for T.37 offramp, 549–552****offramp telephony interface, troubleshooting for T.37 offramp, 556–559****online command mode, 23****onramp gateways, 201–202****onramp mode (T.37), 190****onramp SMTP connection, troubleshooting for T.37 onramp, 540–545****onramp telephony interface, troubleshooting, 532–535****ORCPT parameter (DSN messages), 197****P****packet captures**

- for T.38 fax relay, analyzing, 497–499
- PCM, extracting, 514–515
- performing, 424–428

**packet loss, 215**

- fax relay, troubleshooting, 488–490

**packets**

- IFPs, 156
  - T30\_DATA packets*, 158–161
  - T30\_INDICATOR packets*, 157–158
- NSE, 138–139
- RTP, 133–136

**page encoding. See encoding schemes****PAM (pulse amplitude modulation), 131****passthrough, 129–130. See also relay**

- on 6608 line card, configuring, 295–298
- advanced troubleshooting, 485–486
- on Cisco ATA, configuring, 303–308
- codec upspeed, 137
- comparing with relay, 249–250
- configuring, 287
- DSP functions, troubleshooting, 464–478
- H.323, 144
- HPI debugs, 477–478
- IOS passthrough, configuring, 288
- ITU-T V.152, 147–148
- modem passthrough, comparing with Cisco modem relay, 252. *See also* modem passthrough
- NSE-based, 137–138
  - configuring*, 289–293
  - Event-IDs*, 139
  - fax passthrough*, 139–141
  - modem passthrough*, 141–143

PAM, 131  
 PCM, 130  
 protocol-based, 137  
     *configuring*, 293–294  
     *fax passthrough*, 143–144  
 quantization, 131  
 redundancy considerations for VoIP networks  
     with fax, modem and text capability,  
     221–223  
 text over G.711, configuring, 295  
 versus relay, 151–153  
 on VG248, configuring, 298–303

**Payload Type field (RTP packets), 135–136**

**payload type switching, 148**

**PCM (pulse code modulation), 130**

traces  
     *capturing*, 511–515  
     *of fax calls, interpreting*, 516–519  
     *interpreting*, 510, 515  
     *of modem calls, interpreting*, 520–522

**Phonetype, 109**

**placing text telephone calls, 115**

**playout buffer, 414–415**

**post-message procedure, 63**

**POTS dial peers, 392**

**ppi (pixels per inch), 91**

**PPR (partial page request) messages, 84–86**

**PPS (partial page signal) messages, 84–86**

**premessage procedure, 62**

**processor memory information, displaying, 388**

**protocol timers (G3), 86–87**

**protocol-based passthrough, 137, 143–144**

    configuring, 293–294

**protocol-based switchover**

    for H.323, troubleshooting, 446–451

    for SIP, troubleshooting, 451–454

    T.38 switchover, 169–173

*for SIP, troubleshooting*, 455–459

    Unified CM, 459–461

**protocol-based T.38 support (CUCM), 248**

**prserv utility, 433**

**PSK (phase-shift keying), 29–30**

**PSTN connectivity, testing, 385**

## Q

**QAM (Quadrature Amplitude Modulation), 31**

**QoS considerations for VoIP networks with fax,  
 modem and text capability, 215–218**

    dial peer configuration, 218

    LLQ configuration, 219–221

**quantization, 131**

## R

**ranging, 39**

**receiving text telephone calls, 115**

**Recommendation V.18, 112**

**redundancy considerations for VoIP networks  
 with fax, modem and text capability, 221–223**  
**relay**

    Cisco modem relay, configuring

*for H.323, SIP, and SCCP*, 326–328

*for MGCP*, 329–331

    Cisco text relay, configuring, 332–333

    comparing with passthrough, 249–250

    configuring on Cisco IOS gateways, 311

    DSP functions, 153

*troubleshooting*, 464–478

    fax relay, 154

*Cisco fax relay*, 173–175

*configuring on Cisco IOS gateways*,  
         312–314, 318–325

*default configuration for H.323*, 334–335

*default configuration for SIP*, 334–335

*T.38*, 155–156, 163–173

    modem relay, 175–176

*EC protocols*, 178–179

*NSE messages*, 179–181

    redundancy considerations for VoIP networks

        with fax, modem and text capability, 221–223

    secure modem relay, 254–255

    text relay, Cisco text relay, 181–184

    versus passthrough, 151–153

**relay services**

    HCO, 119

    VCO, 120

**replicating SMTP session, 553**

**resolution, fax scan lines, 91**

**resource utilization considerations for VoIP  
 networks with fax, modem and text capability,  
 224–227**

**response codes (SMTP), 194–195**

**RET parameter (DSN messages), 197**

**retrains, 43**

**RLE (Run Length Encoding), 93**

**RS-232 signaling, 15–18**

**RTC (return to control) signals, 95**

**RTN (retrain negative) messages, 76**

**RTP (retrain positive) messages, 76**

**RTP headers, 133–136**

**Run Length Encoding, 48**

## S

**Saks, Andrew, 109**

**sample SMTP session, 192–193**

**sample T.37 offramp configuration, 373–375**

**sample T.37 onramp configuration, 365–366**

**scan lines, 91**

**SCCP (Skinny Client Control Protocol)**

Cisco modem relay, configuring, 326–328

Cisco text relay, configuring, 339–340

fax relay, configuring on Cisco IOS gateways,  
313–314, 318–320

NSE-based passthrough, configuring, 289–291

T.38 fax relay, configuring, 339–340

**secure modem relay, 254–255**

**service command, 353–355**

**shift synchronization, 123**

**show call active voice brief command, 394–405**

**show call active voice brief id command, 406–407**

**show call history voice brief command, 405–406**

**show controllers t1 command, 408–410**

**show dial-peer voice command, 218**

**show logging command, 389**

**show memory summary command, 388**

**show modem relay statistics pkt command, 506**

**show port voice fdl command, 413**

**show voice call command, 416–419**

**show voice hpi capture command, 514**

**SIP (Session Initiation Protocol)**

Cisco modem relay, configuring,  
326–328, 337–339

Cisco text relay, configuring, 337, 339

fax pass-through, 145

fax relay

*configuring on Cisco IOS gateways,  
313–314, 318, 320*

*default configuration, 334–335*

modem passthrough, configuring, 336–337

NSE-based passthrough, configuring, 289, 291

protocol-based switchover, troubleshooting,  
451–454

T.38 fax relay, configuring, 337, 339

**SK (stop keying), 116**

**SMTP (Simple Mail Transfer Protocol), 191**

commands, 193–194

DSN messages, 195

*NOTIFY parameter, 196–197*

MDN messages, 198–200

*Disposition field, 200–201*

*Notification field, 201*

MTA, 192

response codes, 194–195

sample session, 192–193

sessions, manually replicating, 553

**software-based fax servers, 264, 266**

**software modems, 10–11**

**speedshifts, 42**

**SPIs (service provider interfaces), 465**

**S-registers, 25**

**SRTP (Secure Real-time Transport Protocol)**

**considerations for VoIP networks with fax,  
modem and text capability, 227–228**

**SSE (State Signaling Event) messages, 148**

**standards, 110**

TIA-912, 478

**STS (speech-to-speech) relay, 119**

**successful delivery message (DSN), 197–198**

**Super G3 classification, 58, 88–89, 271**

call analysis, 89

considerations for VoIP networks with fax,  
modem and text capability, 235–237

fax relay, troubleshooting, 490–491

**switchover signaling**

Cisco fax relay switchover, troubleshooting,  
461–464

NSE-based switchovers

*troubleshooting, 430–438*

*validating, 438–445*

protocol-based switchovers

*troubleshooting, 446–459*

*Unified CM, 459–461*

troubleshooting, 428–429

**synchronization considerations for VoIP**

**networks with fax, modem and text capability,  
229–231**

## T

**T.4 specification, 58**

**T.30 fax specification, 58**

fax relay, troubleshooting, 491–496

messages, 63–64, 77–81

protocol timers, 86–87

**T.30 fax calls, 62–63**

**T.37 Recommendation, 189–190. See also T.37**

**offramp; T.37 onramp**

considerations for VoIP networks with fax,  
modem and text capability, 241–243

DSN messages, 197–198

MDN messages, 198–200

*Disposition field, 200–201*

*Notification field, 201*

offramp gateways, 203–204

onramp gateways, 201–202

storing mechanism, 191

- T.37 offramp**
  - configuring, 367
  - dial peers, configuring, 367–368
  - fax page image creation, troubleshooting, 553–556
  - fax send parameters, configuring, 369–371
  - MTA, configuring, 372–373
  - offramp SMTP connection, troubleshooting, 549–552
  - offramp telephony interface, troubleshooting, 556–559
  - sample configuration, 373–375
  - troubleshooting, 545–548
- T.37 onramp**
  - configuring, 354–355, 360
  - DCS\_PACKET parameters, 536
  - dial peers, configuring, 355–360
  - DIS\_PACKET parameters, 536
  - MTA, configuring, 361–365
  - onramp SMTP connection, troubleshooting, 540–545
  - onramp telephony in interface, troubleshooting, 532–535
  - sample configuration, 365–366
  - TCL scripts, loading, 352–353
  - TIFF image creation, troubleshooting, 537–540
  - troubleshooting, 525–532
- T.38. See also T.38 fax relay; T.38 switchover, troubleshooting**
  - CA-controlled fax relay, 321
  - future trends, 185
  - integration with Cisco voice gateway, 272–276
  - integration with CUCM, 276–281
  - NSE-based T.38 fax switchover with CUCM, 245–247
  - protocol-based T.38 support on CUCM, 248
- T.38 fax relay, 155, 263**
  - bandwidth consumption, 211
  - configuring for H.323 and SIP, 337–339
  - configuring for MGCP, 340–342
  - configuring for SCCP, 339–340
  - fax call flow, 163–167
  - NSE-based switchover, 167–169
    - troubleshooting, 436–438*
  - packet captures, analyzing, 497–499
  - protocol-based switchover, 169–173
  - T.30\_DATA packets, 158–161
  - T.30\_INDICATOR packets, 156–158
- T.38 switchover, troubleshooting**
  - for H.323, 446–451
  - for MGCP, 455–459
  - for SIP, 451–455
- T30\_DATA packets, 158–161**
- T30\_INDICATOR packets, 157–158**
- TCF (training check frame) messages, 73**
- TCL scripts**
  - fax detect script considerations for VoIP networks with fax capability, 243–245
  - loading, 352–353
- TCM (Trellis Code Modulation), 32**
- TDM integration with Cisco voice gateway, 269–271**
- telephony/IP troubleshooting. See IP/telephony troubleshooting**
- terminal monitor command, 388**
- terminal to modem communication**
  - asynchronous framing, 19–20
  - DTE/DCE, 15
  - RS-232 signaling, 15–18
  - user interface, 20–25
- termination codes for Cisco modem relay, 476**
- testing connectivity, 384–385**
- text over G.711, 146–147, 256–258**
  - configuring, 295
- text relay, 153**
  - Cisco text relay, 181–184
    - configuring, 332–333*
- text relay modulation command, 333**
- text relay protocol command, 332**
- text relay rtp command, 333**
- text telephones, 110–112, 115**
  - acoustic coupling, 113
  - Baudot text protocol, 121
    - character set, 121–123*
    - FSK, 123–124*
  - call placement, 115
  - carrier-based protocols, 111–112
  - carrierless protocols, 111–112
  - conversation conventions, 116
    - acronyms and abbreviations, 116–117*
  - direct connection, 114
  - history of, 107–109
  - relay services
    - HCO, 119*
    - VCO, 120*
  - TRS, 118–119
- text telephony call legs, viewing, 404–405**
- TGW (terminating gateway), 137**
- TIA/EIA-825-A specification, Baudot character set, 121, 123**
- TIA-912 standard, 478**
- TIFF image creation, troubleshooting for T.37 onramp, 537–540**
- TIFF-F file format, 190**

**timing considerations for VoIP networks with fax, modem and text capability, 229–231****TRN signals, 41****troubleshooting**

basic checks, performing, 383–387

Cisco text relay, 506–510

debugging best practices, 387–91

fax relay, 487

*high delay, 500–502**NSF/NSS messages, 499–500**packet loss, 488–490**Super G3, 490–491**T.30 fax messaging, 491–496***IP***for Cisco IOS gateways, 416–419**for non-IOS gateways, 419–423**packet captures, 424–428*

modem relay, 503–506

passthrough, 485–486

*DSP functions, 464–478*

relay, DSP functions, 464–478

switchover signaling, 428–429

*Cisco fax relay switchover, 461–464**NSE-based switchovers, 430–438**protocol-based switchovers, 446–461*

T.37 store-and-forward fax, 525

*T.37 offramp, 545–559**T.37 onramp, 527–545*

telephony/IP, 407–414

*call legs, 392–407***troubleshooting methodology, 380****TRS (telecommunications relay service), 118–119****TSI (transmitting subscriber identification)**

messages, 71–72

**ttd (telecommunication device), 110****tty, 107, 110****TTY WAV Reader, 258****U-V****Unified CM, protocol-based switchover, 459–461****unassigned payload types, 136****user interface, 20–25****V.150.1 specification, future trends, 185****V.151 specification, future trends, 185****V.17 specification, 61****V.18 specification, 112****V.34 call setup, 35–42****V.34 faxing, 271****V.42 negotiation, 179****V.42bis, 48****VAD (Voice Activity Detection), 137**

effect on bandwidth consumption, 210

**validating NSE-based switchover support, 438–445****VBD (voice-band data), 129****VCO (voice carry over), 119–120****verifying gateway configuration, 386–387****VG248**

fax relay, configuring, 344–347

passthrough, configuring, 298–303

**viewing call legs, 394**

Cisco modem relay call legs, 402–404

fax passthrough call legs, 399–400

fax relay call legs, 400–402

modem passthrough call legs, 394–399

text telephony call legs, 404–405

**Voice Codec Bandwidth Calculator, 210****voice service voip command, 288, 314****VoIP networks**

designing for fax capability, 231

*ECM considerations, 233–235**fallback considerations, 239–241**fax detect script considerations, 243–245**gateway interoperability considerations, 231–233**hairpin call considerations, 237–239**Super G3 considerations, 235–237**T.37 considerations, 241–243**designing for fax, modem and text capability**bandwidth considerations, 209–214**call control protocol considerations,**214–215**QoS considerations, 215–221**redundancy considerations, 221–223**resource utilization considerations, 224–227**SRTP considerations, 227–228**timing/synchronization considerations, 229–231*

dial peers, 39

**VRS (video relay service), 119****W-X-Y-Z****websites**

ITU-T Recommendations, 190

ITU-T V.18 specification, 121

**Weitbrecht, Robert H., 109****Wireshark, 424**

packet captures, performing, 424–428