

MSPP Network Design Example: Cisco ONS 15454

The Cisco ONS 15454 is a highly flexible and highly scalable multiservice Synchronous Optical Network (SONET)/Synchronous Digital Hierarchy (SDH)/dense wavelength-division multiplexing (DWDM) platform. Service providers and enterprise customers use the ONS 15454 to build highly available transport networks for time-division multiplexing (TDM), Ethernet, storage extension, and wavelength services. In this chapter, you will learn the major components of the ONS 15454 system, including these:

- Shelf assembly
- Common control cards
- Electrical interface cards
- Optical interface cards
- Ethernet interface cards
- Storage networking cards

In addition, an example network demand specification is used throughout this chapter to demonstrate Multiservice Provisioning Platform (MSPP) network design using the ONS 15454.

ONS 15454 Shelf Assembly

The ONS 15454 Shelf Assembly is a 17-slot chassis with an integrated fan tray, rear electrical terminations, and front optical, Ethernet, and management connections. Slots 1–6 and 12–17 are used for traffic interface cards; Slots 7–11 are reserved for common control cards. Slots 1–6, on the left side as you face the front of the shelf, are considered Side A; Slots 12–17 are considered Side B. This distinction is important for planning backplane interface types (for electrical card terminations), as well as protection group planning. These issues are covered later in this chapter. The bandwidth capacity of each of the 12 traffic slots varies from 622 Mbps to 10 Gbps, depending upon the type of cross-connect card used. See the section titled “Cross-Connect Cards” later in this chapter for a discussion of the various types available. Table 6-1 summarizes the card slot functions and bandwidth capacities for the ONS 15454 shelf assembly.

Table 6-1 *ONS 15454 Shelf Assembly Slot Functions and Bandwidth Capacities*

Slot Number	Shelf Side	Slot Use	Slot Bandwidth (XCVT System)	Slot Bandwidth (XC10G or XC-VXC-10G System)
1	A	Multispeed high-density slot	622 Mbps/STS-12	2.5 Gbps/STS-48
2	A	Multispeed high-density slot	622 Mbps/STS-12	2.5 Gbps/STS-48
3	A	Multispeed high-density slot; <i>N</i> -protection slot for 1: <i>N</i> protection groups	622 Mbps/STS-12	2.5 Gbps/STS-48
4	A	Multispeed slot	622 Mbps/STS-12	2.5 Gbps/STS-48
5	A	High-speed slot	2.5 Gbps/STS-48	10 Gbps/STS-192
6	A	High-speed slot	2.5 Gbps/STS-48	10 Gbps/STS-192
7	—	TCC Slot	—	—
8	—	XC Slot	—	—
9	—	AIC Slot	—	—
10	—	XC Slot	—	—
11	—	TCC Slot	—	—
12	B	High-speed slot	2.5 Gbps/STS-48	10 Gbps/STS-192
13	B	High-speed slot	2.5 Gbps/STS-48	10 Gbps/STS-192
14	B	Multispeed slot	622 Mbps/STS-12	2.5 Gbps/STS-48
15	B	Multispeed high-density slot; <i>N</i> -protection slot for 1: <i>N</i> protection groups	622 Mbps/STS-12	2.5 Gbps/STS-48
16	B	Multispeed high-density slot	622 Mbps/STS-12	2.5 Gbps/STS-48
17	B	Multispeed high-density slot	622 Mbps/STS-12	2.5 Gbps/STS-48

ONS 15454 Shelf Assembly Backplane Interfaces

Backplane interfaces of the ONS 15454 chassis can be divided into four general areas:

- Power terminal area
- Alarm and chassis ground area

- Side A Electrical Interface Assembly
- Side B Electrical Interface Assembly

Figure 6-1 shows a diagram that identifies the location of each of these areas as you face the rear of the shelf assembly. Electrical Interface Assemblies (EIAs) are required for terminating electrical traffic signals, such as DS1s and DS3s, on the shelf. EIAs are covered in the next section.

Figure 6-1 ONS 15454 Backplane Interfaces

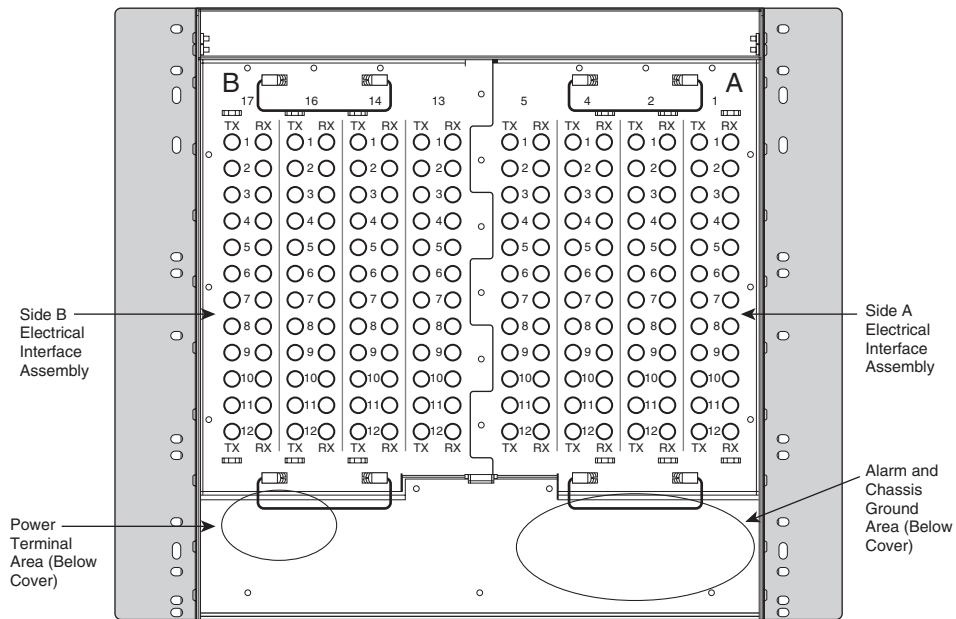

The power terminal area consists of four power terminal screws on the lower-left side. The RET1/BAT1 terminals are for the A power connection; the RET2/BAT2 terminals are for the B connection. These connections are redundant; either can power the entire shelf. The A and B designations do not refer to the A and B sides of the shelf.

The alarm and chassis ground area is located in the rear of the chassis on the lower right side. It has the following terminations:

- **Frame ground terminals**—Two terminals with kepnuts are provided for ground-wire lug connection. This connection ensures that the shelf assembly is at the same electrical potential with the office ground.
- **BITS**—(Building Integrated Timing Supply) This consists of four wire-wrap pin pairs for connection to a BITS or for wiring out to external equipment when the BITS-Out feature is used to supply timing from the ONS 15454.

- **LAN**—(Local-area network) A LAN connects the MSPP node to a management workstation or network. It consists of four wire-wrap pin pairs; typically, two pairs are used.
- **Environmental alarms**—Sixteen wire-wrap pin pairs are provided for external alarms and controls. The Alarm Interface Controller card, covered later in this chapter, is required to use these connections.
- **ACO**—Alarm cutoff, a wire-wrap pin pair that is used to deactivate the audible alarms caused by the contact closures on the shelf backplane. This operation is described in the “Timing, Communications, and Control Cards” section, later in this chapter.
- **Modem**—Four pairs of wire-wrap pins are provided for connecting the ONS 15454 to a modem for remote management.
- **Craft**—Two wire-wrap pin pairs are provided for a TL1 craft-management connection. VT100 emulation software is used to communicate with the system by way of this connection.
- **Local alarms**—Eight wire-wrap pin pairs are used for Critical, Major, Minor, and Remote audible and visual alarms.

EIAs

EIAs are backplane connector panels that must be equipped on the ONS 15454 chassis if you will provide DS1, DS3, or EC-1 services from the node. EIAs are made to fit on either Side A or Side B of the upper section of the backplane. Because Side A consists of the slots that are on the left as you face the front of the shelf assembly, the Side A EIA is installed on the right side as you face the rear. Likewise, the Side B EIA is installed on the left side facing the rear of the shelf assembly.

Various EIAs are available from Cisco, and each side of the shelf can be independently equipped with any type. If no electrical terminations are required for a shelf side, it can be equipped with a blank backplane cover. If there is initially no requirement for electrical connections, and the requirement appears later, the blank backplane cover can be removed and replaced with an EIA while the shelf is powered and in service. You select an EIA based on the type and quantity or density of connections required. These EIA types are available:

- **BNC (Bayonet Neill-Concelman) EIA**—Used for DS3 (clear channel), DS3 Transmux (channelized DS3), and EC-1 services. This EIA type has been made obsolete by newer versions, and Cisco no longer sells it.
- **High-Density (HD) BNC EIA**—Offers the same services as the BNC EIA, with twice the number of available connections.

- **HD mini-BNC EIA**—Offers the same services as the BNC and HD BNC EIAs, with twice as many connections as the HD BNC EIA and four times as many as the BNC EIA. Either the HD mini-BNC EIA or one of the Universal Backplane Interface Connector (UBIC)-type EIAs are required for cabling the HD DS3/EC1 cards.
- **AMP Champ EIA**—Used for DS1 services only.
- **SMB (Sub-Miniature B) EIA**—Can be used for any type of electrical termination, including DS1, DS3, DS3 Transmux, and EC-1.
- **UBIC-V and UBIC-H EIAs**—Can be used for any type and any density electrical interface card termination. These are the most flexible EIA type. The difference between the two is in the orientation of the cable connectors, either vertical (UBIC-V) or horizontal (UBIC-H). Either the UBIC-V or the UBIC-H is required for cabling the high-density DS1 cards.

Table 6-2 provides a summary of the available EIAs, with their associated connector types, supported working shelf slots, and supported electrical interface cards.

Table 6-2 ONS 15454 Electrical Interface Assemblies

EIA Type	Cards Supported	A-Side Connectors	A-Side Slots	B-Side Connectors	B-Side Slots
BNC	DS3-12E DS3N-12E DS3XM-6 DS3XM-12 EC1-12	24 pairs of BNC connectors (2 slots; 12 pairs/slot)	Slot 2 Slot 4	24 pairs of BNC connectors (2 slots; 12 pairs/slot)	Slot 14 Slot 16
High-Density BNC	DS3-12E DS3N-12E DS3XM-6 DS3XM-12 EC1-12	48 pairs of BNC connectors (4 slots; 12 pairs/slot)	Slot 1 Slot 2 Slot 4 Slot 5	48 pairs of BNC connectors (4 slots; 12 pairs/slot)	Slot 13 Slot 14 Slot 16 Slot 17
High-Density mini-BNC	DS3-12E DS3N-12E DS3XM-6 DS3XM-12 DS3/EC1-48 EC1-12	96 pairs of mini-BNC connectors	Slot 1 Slot 2 Slot 4 Slot 5 Slot 6	96 pairs of mini-BNC connectors	Slot 12 Slot 13 Slot 14 Slot 16 Slot 17

continues

Table 6-2 ONS 15454 Electrical Interface Assemblies (Continued)

EIA Type	Cards Supported	A-Side Connectors	A-Side Slots	B-Side Connectors	B-Side Slots
AMP Champ	DS1-14 DS1N-14	6 AMP Champ connectors (1 connector per slot)	Slot 1 Slot 2 Slot 3 Slot 4 Slot 5 Slot 6	6 AMP Champ connectors (1 connector per slot)	Slot 12 Slot 13 Slot 14 Slot 15 Slot 16 Slot 17
SMB	DS1-14 DS1N-14 DS3-12E DS3N-12E DS3XM-6 DS3XM-12 EC1-12	84 pairs of SMB connectors (6 slots; 14 pairs/slot)	Slot 1 Slot 2 Slot 3 Slot 4 Slot 5 Slot 6	84 pairs of SMB connectors (6 slots; 14 pairs/slot)	Slot 12 Slot 13 Slot 14 Slot 15 Slot 16 Slot 17
UBIC-V	DS1-14 DS1N-14 DS1-56 DS3-12E DS3N-12E DS3XM-6 DS3XM-12 DS3/EC1-48 EC1-12	8 pairs of SCSI connectors— vertical orientation	Slot 1 Slot 2 Slot 3 Slot 4 Slot 5 Slot 6	8 pairs of SCSI connectors— vertical orientation	Slot 12 Slot 13 Slot 14 Slot 15 Slot 16 Slot 17
UBIC-H	DS1-14 DS1N-14 DS1-56 DS3-12E DS3N-12E DS3XM-6 DS3XM-12 DS3/EC1-48 EC1-12	8 pairs of SCSI connectors— horizontal orientation	Slot 1 Slot 2 Slot 3 Slot 4 Slot 5 Slot 6	8 pairs of SCSI connectors— horizontal orientation	Slot 12 Slot 13 Slot 14 Slot 15 Slot 16 Slot 17

Figure 6-2 shows two examples of EIAs, the HD BNC and the AMP Champ.

Figure 6-2 *EIA Examples: HD BNC and AMP Champ*

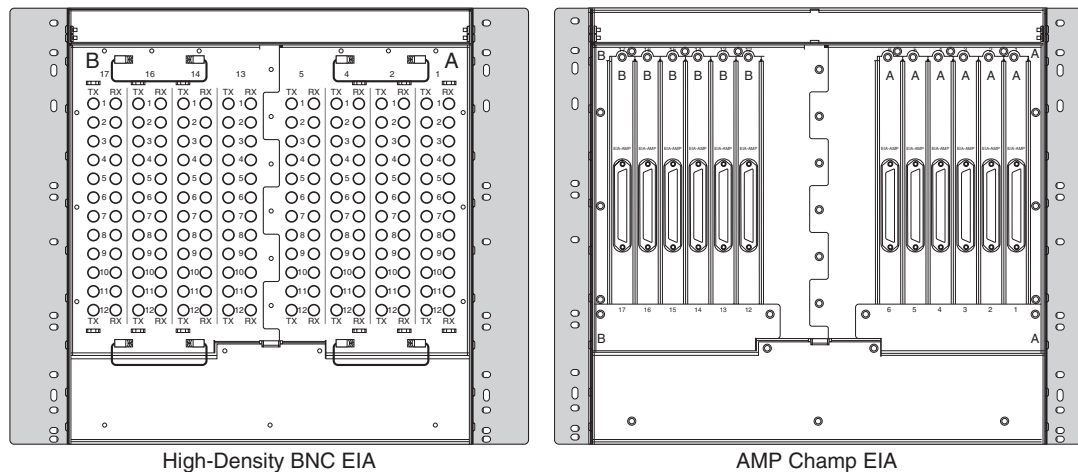

Timing, Communications, and Control Cards

The Timing, Communications, and Control (TCC) cards are required for operation of the ONS 15454 MSPP system and are installed in a redundant pair in shelf Slots 7 and 11. Two current versions are available from Cisco: the Advanced Timing, Communications, and Control card (TCC2), and the Enhanced Advanced Timing, Communications, and Control card (TCC2P). Both perform the same basic functions, but the TCC2P is an updated version of the TCC2 and includes some security enhancements and additional synchronization options that are not available in the TCC2. Both cards have a purple square symbol on their faceplates, which corresponds to matching symbols on the front of the ONS 15454 shelf assembly. This serves as an aid in easily identifying the correct location to install the card. TCC cards are the only card type allowed in Slots 7 and 11, and both slots should always be equipped. Cisco does not support the operation of the ONS 15454 MSPP system with only a single TCC card installed. Although the system technically can function with only a single card, the second card is necessary for redundancy and to allow for continuity of system traffic in case of a failure or reset of the primary card. The system raises the “Protection Unit Not Available” (PROTNA) alarm if the secondary TCC card is not installed.

Two earlier versions of the TCC2 and TCC2P cards exist, called simply the Timing, Communications, and Control (TCC) card and the TCC Plus (TCC+). These older-version TCC cards provide similar functionality to the current cards, but they are much more limited in processing power. Although they may be installed in some existing systems, Cisco no longer produces the TCC or TCC+ versions.

The TCC2 and TCC2P cards perform a variety of critical system functions, which are as follows:

- **System initialization**—The TCC2s/TCC2Ps are the first cards initially installed in the system and are required to initialize system operation.
- **Data communications channels (DCCs) termination and processing**—The DCCs, which allow for communications and remote management between different MSPP network elements, are processed by the TCC2/TCC2P card. The TCC card automatically detects DCC-connected nodes.
- **Software, database, and Internet Protocol (IP) address storage**—The node database, system software, and assigned system IP address (or addresses) are stored in nonvolatile memory on the TCC2/TCC2P card, which allows for quick restoration of service in case of a complete power outage.
- **Alarm reporting**—The TCC2/TCC2P monitors all system elements for alarm conditions and reports their status using the faceplate and fan tray light-emitting diodes (LEDs). It also reports to the management software systems.
- **System timing**—The TCC card monitors timing from all sources (both optical and BITS inputs) for accuracy. The TCC selects the timing source, which is recovered clocking from an optical port, a BITS source, or the internal Stratum level 3 clock.
- **Cell bus origination/termination**—The TCC cards originate and terminate a cell bus, which allows for communication between any two cards in the node and facilitates peer-to-peer communication. These links are important to ensure fast protection switching from a failed card to a redundant-protection card.
- **Diagnostics**—System performance testing is enabled by the TCC cards. This includes the system LED test, which can be run from the faceplate test button on the active TCC or using Cisco Transport Controller (CTC).
- **Power supply voltage monitoring**—An alarm is generated if one or both of the power-supply connections is operating at a voltage outside the specified range. Allowable power supply voltage thresholds are provisionable in CTC.

Figure 6-3 shows a diagram of the faceplate of the TCC2/TCC2P card.

The two card types are identical in appearance, with the exception of the card name labeling. The cards have 10 LEDs on the faceplate, including the following:

- **FAIL**—This red LED that is illuminated during the initialization process. This LED flashes as the card boots up. If the LED does not extinguish, a card failure is indicated.
- **ACT/STBY**—Because the TCC cards are always installed as a redundant pair, one card is always active while the other is in standby state. The active TCC2/TCC2P has a green illuminated ACT/STBY LED; the standby card is amber/yellow.
- **PWR A and B**—These indicate the current state of the A- and B-side power-supply connections. A voltage that is out of range causes the corresponding LED to illuminate red; an acceptable level is indicated with green.

Figure 6-3 TCC2/TCC2P Faceplate Diagram

- **CRIT, MAJ, and MIN**—These indicate the presence of a critical (red), major (red), or minor (amber) alarm (respectively) in the local ONS 15454 node.
- **REM**—This LED turns red if an alarm is present in one or more remote DCC-connected systems.
- **SYNC**—This green SYNC lamp indicates that the node is synchronized to an external reference.

- **ACO**—The Alarm Cutoff lamp is illuminated in green if the ACO button on the faceplate is depressed. The ACO button deactivates the audible alarm closure on the shelf backplane. ACO stops if a new alarm occurs. If the alarm that originated the ACO is cleared, the ACO LED and audible alarm control are reset.

The faceplate also has two push-button controls. The LAMP TEST button initiates a brief system LED test, which lights every LED on each installed card and the fan tray LEDs (with the exception of the FAN FAIL LED, which does not participate in the test).

The RS-232 and Transmission Control Protocol/Internet Protocol (TCP/IP) connectors allow for management connection to the front of the ONS 15454 shelf. TCP/IP is an RJ-45 that allows for a 10Base-T connection to a PC or workstation that uses the CTC management system. A redundant local-area network (LAN) connection is provided via the backplane LAN pins on the rear of the shelf. The RS-232 is an EIA/TIA-232 DB9-type connector used for TL1 management access to the system. The CRAFT wire-wrap pins on the shelf backplane duplicate the functionality of this port.

Cross-Connect Cards

The cross-connect (XC) cards are required for operation of the ONS 15454 MSPP system and are installed in a redundant pair in shelf Slots 8 and 10. Three versions currently are available from Cisco: XCVT, XC10G, and XC-VXC-10G. Each version has both a high-order (STS-N) cross-connect fabric and a low-order virtual tributary (VT1.5) fabric. All three perform the same basic functions, but they feature varying cross-connect capacities. Table 6-3 summarizes the high-order and low-order cross-connect capacities of the XCVT, XC10G, and XC-VXC-10G cards. The meanings of these capacities are covered later in this section.

Table 6-3 ONS 15454 XC Card Capacities

Cross-Connect Card	High-Order (STS-1) Capacity	Low-Order (VT1.5) Capacity
XCVT	288	672
XC10G	1152	672
XC-VXC-10G	1152	2688

The XCVT, XC10G, and XC-VXC-10G have green cross symbols on their faceplates, which correspond to matching symbols on the front of the ONS 15454 shelf assembly. This serves as an aid in easily identifying the correct location to install the cards. The XC card types are the only cards allowed in Slots 8 and 10 for the MSPP, and both slots should always be equipped. Cisco does not support the operation of the ONS 15454 MSPP system with only a single XCVT, XC10G, or XC-VXC-10G installed. Although the system will technically function with only a single card, the second card is necessary for redundancy and to allow for continuity of system traffic.

An earlier version of the cross-connect card is called simply the XC card. This older version provides a 288 STS-1 fabric, which is the same size as the high-order fabric in the Cross-Connect Virtual Tributary (XCVT). However, the XC card does not support low-order (VT1.5) grooming, and systems that are equipped with the XC card cannot drop DS1 circuits. Although it can be installed in some existing systems, Cisco no longer produces the XC card.

The XCVT, XC10G, and XC-VXC-10G cards have only two faceplate LEDs. The red FAIL LED illuminates during a reset and flashes during the boot process to indicate that the card's processor is not ready for operation. If the FAIL LED does not extinguish, this is an indication that the card has failed and needs to be replaced. The ACT/STBY LED indicates whether the card is the active (green) or standby (amber) card in the redundant pair.

Cross-Connect Card Bandwidth

Each of the three cross-connect card types has a high-order (STS-1) and low-order (VT1.5) capacity, as shown in Table 6-3. For example, the XC10G card has an STS-1 capacity of 1152 STS terminations. Each STS-1 circuit requires at least two terminations, one for entering (ingress) and one for exiting (egress) the cross-connect matrix. Therefore, a single Bidirectional Line Switch Ring (BLSR) circuit, a pass-through circuit, or an unprotected circuit consumes two terminations of the available capacity. In a Unidirectional Path-Switched Ring (UPSR) circuit-termination node, an STS-1 circuit consumes three matrix terminations because of the signal bridging that occurs to enable UPSR protection. As an example, a DS3 circuit in a UPSR termination node would use three STS-1 terminations (of the available 1152 for the XC10G or XC-VXC-10G, or the available 288 for the XCVT).

VT1.5-Level cross-connections are made via logical STS ports in the VT matrix of the various cross-connect cards. The XCVT and XC10G VT matrices have 24 logical STS ports ($24 \text{ STS ports} \times 28 \text{ VT1.5/port} = 672 \text{ VT capacity}$); the XC-VXC-10G has 96 logical STS ports ($96 \text{ STS ports} \times 28 \text{ VT1.5/port} = 2688 \text{ VT capacity}$). To fully use the VT matrix capacity, each STS port must carry 28 VT1.5 circuits. Because of this, stranded capacity can occur when using, for example, a DS1-14 card as a circuit source/destination. Because the 14 DS1s from the DS1-14 card's 14 ports are carried to the cross-connect matrix on an STS-1, the remaining 14 VT1.5 capacity within the STS-1 is unused on the VT cross-connect matrix.

To further aid in understanding the way the cross-connect matrixes operate on the ONS 15454, see Figures 6-4 and 6-5. Figure 6-4 shows a VT1.5 circuit from a DS1-14 card in a BLSR termination node; Figure 6-5 shows the same circuit in a UPSR termination node. Note the matrix use information shown for each of the figures.

NOTE The transition connections between the STS (high-order) matrix and the VT (low-order) matrix are not counted when calculating ports used on the STS (high-order) matrix.

Figure 6-4 VT Matrix Use for a DS1 Circuit in a BLSR Termination Node

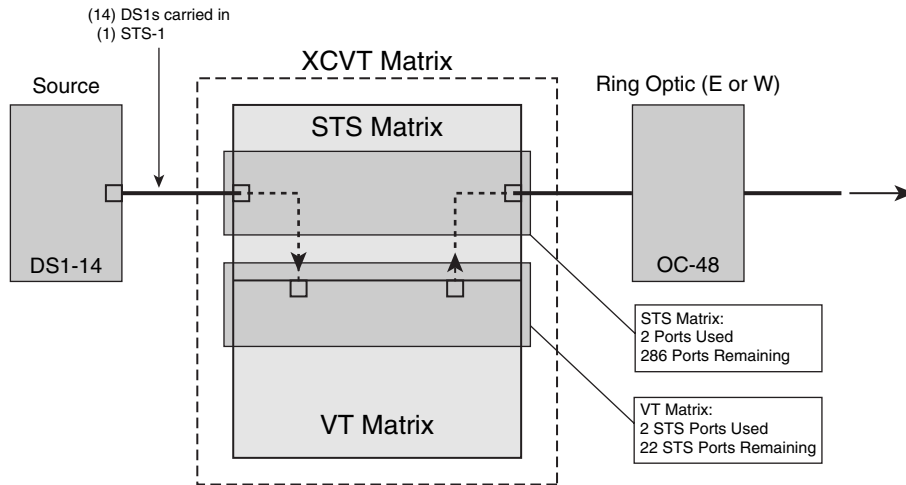
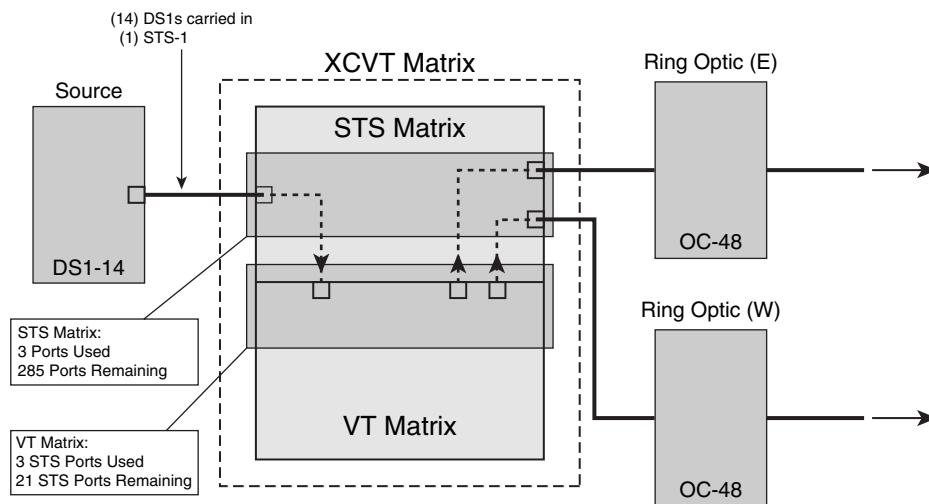

Figure 6-5 VT Matrix Use for a DS1 Circuit in a UPSR Termination Node



Alarm Interface Controller Card

The Alarm Interface Controller (AIC-I) card is an optional circuit pack that is installed in shelf Slot 9. The faceplate of the card is marked with a red diamond, corresponding to the symbol marked on the front of the ONS 15454 shelf assembly. This serves as an aid in easily identifying the correct location to install the card. For MSPP sites where the AIC-I

is not required, a BLANK/FILLER is required to maintain proper airflow through the system while operating without the front door, and also to allow the system to meet Network Equipment Building Standards (NEBS), electromagnetic interference (EMI) standards, and electrostatic discharge (ESD) standards.

When is the AIC-I card required? The card provides four main capabilities to the network operator:

- Environmental alarm connection and monitoring
- Embedded voice-communication channels, known as orderwires
- A-Side and B-Side power supply input voltage monitoring
- Access to embedded user data channels

You examine each of these major functions, as well as the associated card faceplate LEDs and cabling connectors, in this section. Figure 6-6 shows the faceplate layout of the AIC-I.

An earlier version of the Alarm Interface Controller is called the AIC (no -I). This older version provides a more limited environmental alarm-monitoring capacity and does not provide user data channel access or input voltage monitoring. Although they may be installed in some existing systems, Cisco no longer produces the AIC version.

Similarly to all ONS 15454 common control cards, the AIC-I has a FAIL LED and ACT LED on the upper part of the card faceplate, just below the top latch. The FAIL LED is red and indicates that the card's processor is not ready for operation. This LED is normally illuminated during a card reset, and it flashes during the card boot-up process. If the FAIL LED continues to be illuminated, this is an indication that the card hardware has experienced a failure and should be replaced. The ACT (Active) LED is green and illuminates to indicate that the card is in an operational state. Unlike the XC cards and TCC cards, the ACT LED does not have a standby (STBY) state because there is no secondary or back-up card to protect the active AIC-I card. If the card fails, the system can continue to operate normally, with the exception of the functionality provided by the AIC-I.

Environmental Alarms

Environmental alarms are associated with events that affect the operation of the system and are specific to the surrounding environment and external support systems at an MSPP node location. These alarms are usually provisioned and monitored at locations other than those staffed and maintained by a carrier (for example, a central office). This can include an end-user customer's telecom equipment room or an outside plant location, such as a controlled-environment vault (CEV) or concrete hut. Some examples of these alarms include power system performance degradation or failure, hazardous condition alarms (for example, smoke, heat, rising water, and so on), and intrusion alarms (for example, unauthorized entry into a secured area). The ONS 15454 can use the alarm-monitoring capability of the AIC-I to report alarms via the SONET overhead back to the network operations center for trouble

resolution or dispatch of maintenance personnel. Figure 6-7 shows an example of this application. A pair of LEDs, labeled as INPUT and OUTPUT, are included on the card faceplate, and illuminate when any input alarm or output control are active.

Figure 6-6 *AIC-1 Card Faceplate Diagram*

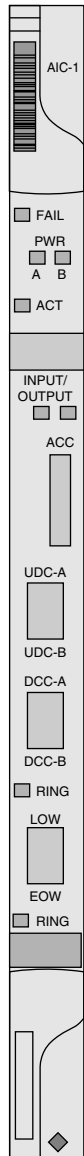
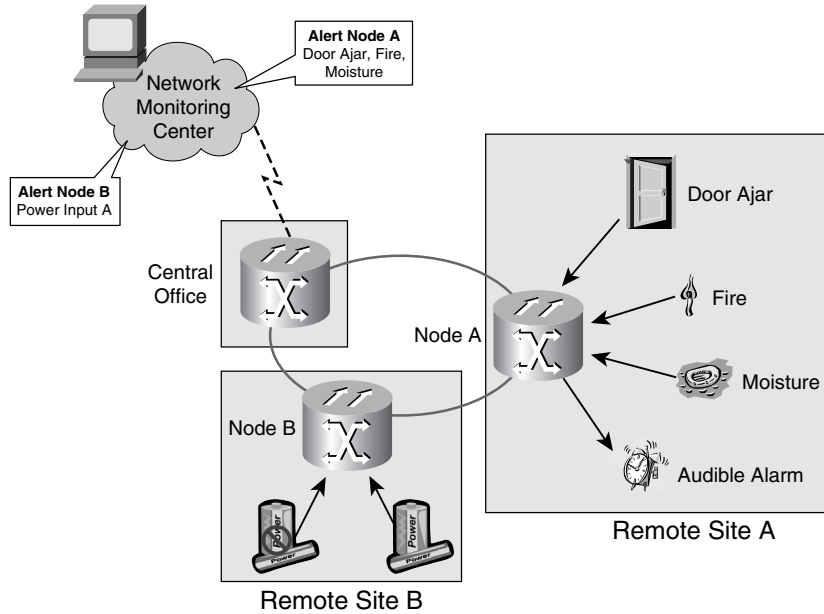
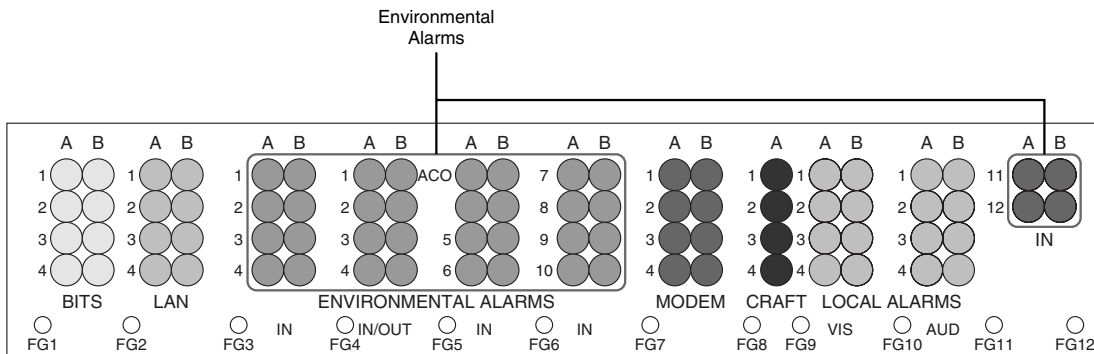

Figure 6-7 Environmental Alarms Reported Using AIC-I Card Interfaces



CTC enables the user to provision several parameters related to the operation of the environmental alarms, including an assigned severity (Critical, Major, Minor, or Not Reported), an alphanumeric alarm description, and the capability to set the alarm to be raised upon detection of an “open” or “closed” condition across the alarm contacts. The AIC-I card provides 12 alarm input connections and 4 additional connections that are provisionable as either inputs or outputs. An output is used to control operation of an external device, such as an alarm-indication lamp or a water pump. The backplane of the ONS 15454 chassis has 16 wire-wrap pin pairs for connection to the external equipment to be monitored or controlled. Figure 6-8 shows these connections.

Figure 6-8 Backplane Environmental Alarm Connections



By using an additional piece of hardware, called the Alarm Expansion Panel (AEP), the AIC-I can actually be used to provide up to 32 alarm inputs and 16 outputs, for a total of 48 connections. The AEP is a connector panel that is wired to a subset of the environmental alarm wire-wrap pins and attached to the backplane. Cables can then be installed from the AEP to an external terminal strip for connecting alarm contacts to the system.

One interesting application that involves the use of both an environmental alarm and a control is referred to as a “virtual wire.” A virtual wire enables the user to consider the activation of an incoming environmental alarm as triggering the activation of a control. Figure 6-9 encourages this: One such scenario is shown in Figure 6-9, where the activation of an alarm at the remote location of Node A causes a control to activate an audible alarm at the staffed location of Node B. A virtual wire is used to associate the alarm with the control activation.

Figure 6-9 *Virtual Wire Operation*

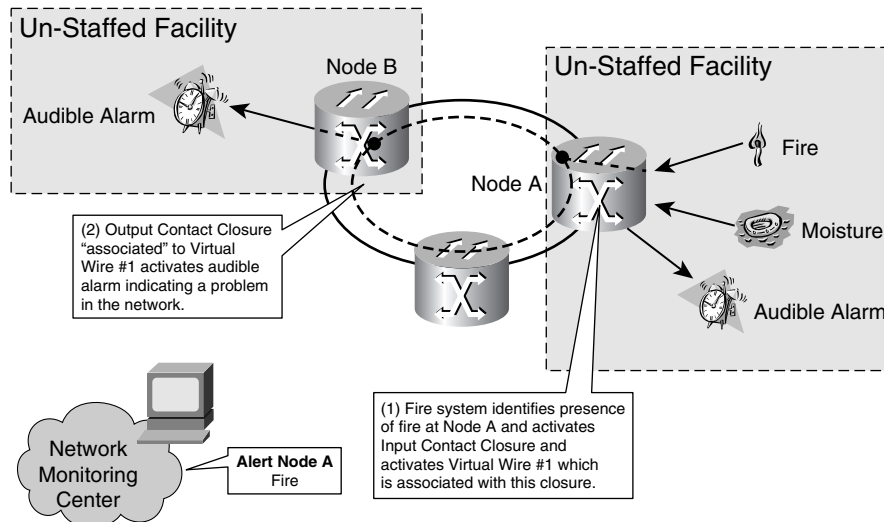

Orderwires

Orderwires allow technicians to attach a phone to the faceplate of the AIC-I card and communicate with personnel at other ONS 15454 MSPP sites. The AIC-I provides two separate orderwires, known as local and express. These can be used simultaneously, if desired. The local orderwire uses the E1 byte in the Section overhead to provide a 64-kbps voice channel between section-terminating equipment, while the express orderwire uses the E2 byte in the Line overhead to provide a channel between line-terminating equipment. Both orderwires operate as broadcast channels, which means that they essentially behave

as party lines. Anyone who connects to an orderwire channel can communicate with everyone else on the channel.

Phone sets are connected to the AIC-I using the two standard RJ-11 jacks marked LOW (Local Orderwire) and EOW (Express Orderwire). A green LED labeled RING is provided for each jack. The LED lights and a buzzer/ringer sounds when the orderwire channel detects an incoming call.

Power Supply Voltage Monitoring

The AIC-I monitors the A and B power supply connections to the ONS 15454 for the presence of voltage, under-voltage, and over-voltage. Two bicolor LEDs are provided on the AIC-I faceplate for visual indication of either normal (green) or out-of-range (red) power levels. These LEDs are marked as PWR A and PWR B, and are located on the upper portion of the faceplate between the FAIL and ACT LEDs. The TCC2 and TCC2P controller cards also monitor the A and B power supplies for the chassis, and will override this feature of the AIC-I if installed in the same shelf. The TCC2/TCC2P force the power monitor LEDs on the AIC-I faceplate to match the state of their power-monitor LEDs. Because the older TCC+ controller cards do not include the power-monitoring feature, this feature of the AIC-I is more useful when installed with them.

User Data Channels

Four point-to-point data communications channels are provided for possible network operator use by the AIC-I, with two user data channels (UDC-A and UDC-B) and two data communications channels (DCC-A and DCC-B). These channels enable networking between MSPP locations over embedded overhead channels that are otherwise typically unused. The two UDCs are accessed using a pair of RJ-11 faceplate connectors; the two DCCs use a pair of RJ-45 connectors.

The UDC-A and UDC-B channels use the F1 Section overhead byte to form a pair of 64-kbps data links, each of which can be routed to an individual optical interface for connection to another node site. The DCC-A and DCC-B use the D4-D12 line-overhead bytes to form a pair of 576-kbps data links, which are also individually routed to an optical interface.

SONET/SDH Optical Interface Cards

All current industry-standard SONET/SDH interface types are available for the ONS 15454 platform, including OC-3/STM-1, OC-12/STM-4, OC-48/STM-16, and OC-192/STM-64. These interface cards are typically distinguished by bandwidth, wavelength, and number of ports; however, with the newer interfaces based on Small Form Factor Pluggable (SFP/XFP) technology, these parameters can vary from port to port on the same interface card.

Therefore, we briefly discuss the available card types in terms of two categories: fixed optics interfaces and modular optics interfaces.

Fixed optics interfaces are those for which the bandwidth (for example, OC-12/STM-4), the wavelength (for example, 1310 nm), and the number of equipped ports (for example, a four-port OC-12/STM-4 interface card) are predetermined parameters that cannot be field-modified. Table 6-4 gives a listing of these interfaces, including card name, SONET/SDH bandwidth for each port, transmitter wavelength, the number of ports included on the interface card, and the quantity and type of optical fiber connectors on the card's faceplate.

NOTE Each port has two associated connectors, one for the transmitter and one for the receiver.

Table 6-4 *ONS 15454 Fixed Optics Interfaces*

Card Name	Per-Port Bandwidth (Mbps)	Wavelength (nm)	Number of Ports	Connectors
OC3 IR 4/STM1 SH 1310	155.52	1310	4	8 SC
OC3 IR/STM1 SH 1310-8	155.52	1310	8	16 LC
OC12 IR/STM4 SH 1310	622.08	1310	1	2 SC
OC12 LR/STM4 LH 1310	622.08	1310	1	2 SC
OC12 LR/STM4 LH 1550	622.08	1550	1	2 SC
OC12 IR/STM4 SH 1310-4	622.08	1310	4	8 SC
OC48 IR/STM16 SH AS 1310	2488.32	1310	1	2 SC
OC48 LR/STM16 LH AS 1550	2488.32	1550	1	2 SC
OC48 ELR/STM16 EH 100 GHz	2488.32	Various*	1	2 SC
OC192 SR/STM64 IO 1310	9953.28	1310	1	2 SC
OC192 IR/STM64 SH 1550	9953.28	1550	1	2 SC
OC192 LR/STM64 LH 1550	9953.28	1550	1	2 SC
OC192 LR/STM64 LH ITU 15xx.xx	9953.28	Various*	1	2 SC

*Multiple different cards are included in this "family" of cards, with wavelengths corresponding to the ITU DWDM frequency grid.

A card name that includes the IR (and SH) designations indicates a card designed for intermediate-reach (short-haul) applications. A card with the LR/LH designations indicates a long-reach/long-haul card. Similarly, ELR/EH (extended long reach/extended haul) and SR (short reach) are indicative of the card's transmission distance specifications.

Modular optics interfaces are those for which the bandwidth, the wavelength, and possibly even the number of equipped ports are parameters that are made flexible through the use of SFPs or XFPs. SFPs and XFPs are essentially electrical-to-optical signal converters that provide a modular interface between a port on an interface card and the external fiber-optic cabling. SFPs and XFPs are similar in design; the primary difference is the module size (XFPs are larger). Modular optics are available for various wavelengths, optical reaches, and technologies, such as SONET/SDH and Gigabit Ethernet (GigE). An SFP or XFP is inserted into the required card port faceplate receptacle and provides a transmit/receive pair of LC fiber connectors. Figure 6-10 shows a group of SFPs, as well as an enlarged view of an SFP connector end.

Figure 6-10 *SFP Interface Modules*

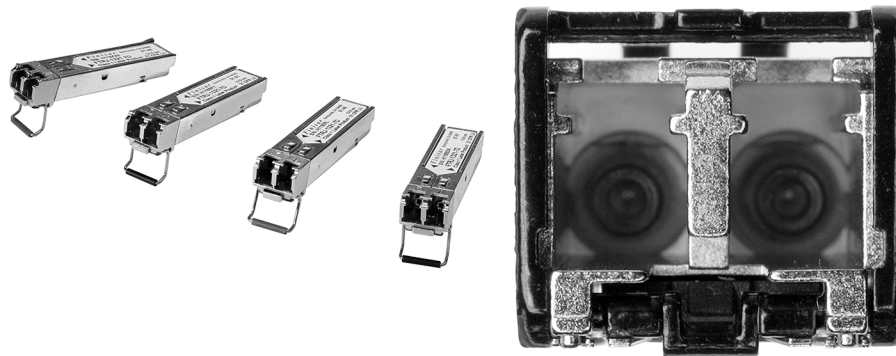

Currently, two SONET/SDH interfaces take advantage of SFP/XFP technology to offer user flexibility and maintenance spare savings:

- **OC-192/STM-64 Any Reach**—This is a 10G interface card with a single XFP port capable of housing an SR, IR, or LR XFP module. Having a single card to stock (while maintaining a maintenance inventory of 10G XFPs) allows a carrier customer to realize efficiencies in maintenance sparing.
- **MRC-12**—The 12-port multirate card (MRC) contains 12 modular SFP receptacles, with the various ports capable of being equipped for OC-3/STM-1, OC-12/STM-4, or OC-48/STM-16 operation. In addition to savings related to maintenance sparing, this card enables the network operator to equip ports for SONET/SDH services on demand. This flexibility also allows for a much more efficient use of chassis slots. For example, a single MRC-12 card can be equipped with one or more OC-48/STM-16 ports,

one or more OC-12/STM-4 ports, and one or more OC-3/STM-1 ports, and to use only a single card slot in the chassis instead of a minimum of three slots if fixed interface card types were used. Combinations of each port type can be used, up to the maximum available slot bandwidth, which varies based on the equipped cross-connect card type.

Ethernet Interface Cards

Ethernet interface cards are used in the ONS 15454 platform to enable a service provider or network operator to integrate Ethernet into the SONET/SDH bandwidth. This allows data traffic to share the same transport platform as time-division multiplexing (TDM) links. Ethernet interface cards can be used for 10-Mbps, 100-Mbps, and 1000-Mbps (or GigE) signals, as well as subrate signals for each of these interface types. Some Ethernet interface cards, such as the G-Series and CE-Series, provide transport (or Layer 1) services; other card types enable switching (Layer 2) as well as routing (Layer 3) functionality.

Transport (Layer 1) Ethernet Service Interfaces

Layer 1 Ethernet transport services, which are enabled using point-to-point ONS 15454 circuits, are provided using either the G-Series or CE-Series Ethernet interface cards. This type of service can also be provided using the E-Series cards when operated in what Cisco calls Port-Mapped mode. Table 6-5 provides a summary of these cards.

Table 6-5 ONS 15454 Transport (Layer 1) Ethernet Service Interface Summary

Card Name	Per-Port Maximum Bandwidth	Number of Ports	Connectors
G1000-4	1000 Mbps	4	4 GBIC (SC) receptacles
G1K-4	1000 Mbps	4	4 GBIC (SC) receptacles
E1000-2	1000 Mbps	2	2 GBIC (SC) receptacles
E1000-2-G	1000 Mbps	2	2 GBIC (SC) receptacles
E100T-12	100 Mbps	12	12 RJ-45 jacks
E100T-G	100 Mbps	12	12 RJ-45 jacks
CE-100T-8	100 Mbps	8	8 RJ-45 jacks

G-Series Ethernet Interface Cards

The G-Series interface cards are used to provide transport bandwidth for Ethernet frame forwarding between two locations in an MSPP network for point-to-point services. The bandwidth that can be allocated for linking G-Series ports is user-selectable, from a minimum of a single STS-1 up to full line-rate GigE. The G1000-4 and G1K-4 are hardware equivalents; the only difference between the two versions is XC card compatibility. The G1000-4 card is always limited to use with the XC10G cross-connect card and cannot be used in a chassis equipped with XCVT cross-connect cards. The G1K-4 card is a later version with additional flexibility. When ONS 15454 Software Release 4.0 or higher is used, the G1K-4 can be used with XCVT cross-connect cards; its use is limited to the high-speed slots (Slots 5, 6, 12, and 13).

G-Series cards have four Gigabit Interface Converter (GBIC) ports on the card faceplate. GBICs are similar in concept to SFPs, but in a larger physical package and with SC fiber connectors instead of an LC pair. Figure 6-11 shows a group of GBIC modules.

Figure 6-11 GBIC Modules



Each G-Series card GBIC receptacle can be independently equipped with SX (short reach 850 nm), LX (long reach 1300 nm), ZX (extended reach 1550 nm), Coarse DWDM, or DWDM GBICs. Each card has an LED labeled ACT, which indicates the card's status, and an LED labeled FAIL, which remains illuminated if the card's processor is not ready or if a failure has occurred. Additionally, each of the four ports has a status LED, labeled ACT/LINK. A solid green ACT/LINK lamp indicates that a link is not carrying traffic; a flashing ACT/LINK lamp means that the link is active and carrying traffic. A solid amber ACT/LINK lamp indicates that there is link but that traffic is inhibited, such as when a circuit has not been built to the port or when the port has not been enabled.

Circuits for carrying Ethernet frames are built from a single port on a G-Series card in one MSPP node to another single port on a G-Series card in another MSPP node. The G-Series cards permit contiguously concatenated circuits of certain sizes. The allowable sizes that can be accommodated in the SONET platform are STS-1, STS-3c, STS-6c, STS-9c, STS-12c, STS-24c, and STS-48c. The maximum bandwidth that can be provisioned to a single G-Series card is 48 STS-1 equivalents.

One restriction exists for the circuit sizes that can be used with the G-Series cards, which could preclude the network operator from using the full 48 STS-1 bandwidth. This restriction is applicable to instances in which a single line-rate circuit (STS-24c) and one or more subrate circuits are used on the same card. In this case, the total bandwidth of the subrate circuits is limited to a maximum of 12 STS-1s. To realize the full bandwidth capability (48 STS-1s) of the G-Series card, the possible combinations are either two line-rate circuits or a combination of up to four subrate circuits with total bandwidth of 48 STS-1s.

Besides Ethernet transport between two sites, there is one additional application for the G-Series Ethernet interface cards. These interfaces can also be configured for use as transponders. This would enable a conventional SX, LX, or ZX Gigabit interface to be converted to a dense wavelength-division multiplexing (DWDM) or coarse wavelength-division multiplexing (CWDM)-compatible wavelength signal, and to be directly connected to a DWDM/CWDM filter system. In this mode, the traffic passing through the G-Series card does not access the cross-connect fabric; this simply provides a method for conditioning Ethernet signals for transport across an xWDM network.

CE-Series Ethernet Interface Cards

Much like the G-Series, the CE-100T-8 interface card is used to provide transport bandwidth for Ethernet frame forwarding between two locations in an MSPP network for point-to-point services. The bandwidth that can be allocated for linking CE-Series ports is user-selectable, from a minimum of a single VT1.5, up to full line-rate 100Base-T Ethernet. The CE-100T-8 requires ONS 15454 software version 5.0.2 or higher and can be used in any of the 12 system traffic slots.

CE-100T-8 cards have eight 10/100 RJ-45 Ethernet ports on the card faceplate. Each card has an LED labeled ACT, which indicates the card's status, and an LED labeled FAIL, which remains illuminated if the card's processor is not ready or if a failure has occurred. Additionally, each of the eight ports has an ACT LED (amber) and a LINK LED (green). A solid green LINK lamp indicates that a link exists. A blinking amber ACT lamp indicates that traffic is being transmitted and received over the link.

Circuits built to connect ports on CE-100T-8 cards can be either contiguously concatenated or virtually concatenated, and either low order (VT1.5) or high order (STS-1 or STS-3c).

Combinations of the various circuit types and sizes are allowed. Some example circuits include these:

- **Line rate 100BASE-T**—To carry a full 100-Mbps signal, an STS-3c or an STS-1-3v can be provisioned.
- **Line rate 10BASE-T**—To carry a full 10-Mbps signal, an STS-1 (inefficient) can be used. A better option is a VT1.5-7v.
- **Subrate 100BASE-T**—An STS-1 can carry approximately 49 Mbps, or a VT1.5-14v can be used to provide 20-Mbps service.

Additional information on circuit sizing and CE-Series applications is provided in Chapter 7, “ONS 15454 Ethernet Applications and Provisioning.”

E-Series Ethernet Interface Cards

The E-Series Ethernet cards can be used to provide Layer 1 transport or Layer 2 switched Ethernet services. Layer 1 services are provided when the cards on either end of a circuit (or circuits) are set up in what is known as port-mapped or linear-mapper mode. In this mode, Layer 2 features are disabled. The E-Series card works in a similar manner to the CE-100T-8.

Two types of E-Series cards exist, and there are two versions for each type, making a total of four cards in the set. The 10/100Base-T versions are the E100T-12 and the E100T-G. The difference between the two cards is that the E100T-12 can operate only with the XCVT cross-connect cards; the newer E100T-G does not have this restriction. The 1000-Mbps versions are the E1000-2 and the E1000-2-G. Like the 10/100 cards, the difference between these two cards is that the E1000-2 is supported only in systems equipped with the XCVTs; while the newer E1000-2-G is not limited to XCVT systems.

The E100T cards have 12 10/100 RJ-45 Ethernet ports on their faceplates; the E1000 cards have two GBIC receptacles. The E1000 cards can be equipped with either SX or LX GBICs. All E-Series cards have an LED called ACT, which indicates the card's status, and an LED labeled FAIL, which remains illuminated if the card's processor is not ready or if a failure has occurred. Additionally, each card has a port LED, which is green to indicate a link and amber to indicate that the port is active.

The E-Series cards are hardware-limited to a maximum circuit-termination size of STS-12c. Therefore, although a line-rate 100-Mbps Ethernet circuit can be provisioned to a port on the E100T cards, a GigE circuit provisioned to a port on the E1000 cards is bandwidth-limited to a maximum of 600 Mbps. The available circuit sizes for the E-Series cards in port-mapped mode are STS-1, STS-3c, STS-6c, and STS-12c. The E-Series cards do not support high-order or low-order virtual concatenation (VCAT) circuits.

Switching (Layer 2) and Routing (Layer 3) Ethernet Service Interfaces

Layer 2 and Layer 3 Ethernet services can be provisioned on an ONS 15454 network using the E-Series (Layer 2 only) and ML-Series (Layer 2/Layer 3) interface cards. These cards can be used to build multipoint, switched services over the SONET network, such as shared packet rings or resilient packet rings (RPR). Chapter 7 covers these services in detail. Table 6-6 provides a summary of these cards.

Table 6-6 ONS 15454 Switching/Routing Ethernet Service Interface Summary

Card Name	Per-Port Maximum Bandwidth	Number of Ports	Connectors
ML100T-12	100 Mbps	12	12 RJ-45 jacks
ML1000-2	1000 Mbps	2	2 SFP (LC) receptacles
ML100-FX	100 Mbps	8	8 SFP (LC) receptacles
E1000-2	1000 Mbps	2	2 GBIC (SC) receptacles
E1000-2-G	1000 Mbps	2	2 GBIC (SC) receptacles
E100T-12	100 Mbps	12	12 RJ-45 jacks
E100T-G	100 Mbps	12	12 RJ-45 jacks

E-Series Ethernet Interface Cards

The E-Series Ethernet interface cards, previously discussed within this chapter, can be used to provide Layer 2 services, such as virtual local-area network (VLAN) connectivity when provisioned in single-card EtherSwitch or multicard EtherSwitch mode. Chapter 7 covers these applications in detail.

ML-Series Ethernet Interface Cards

The ML-Series cards are Layer 2/Layer 3 switching cards that are integrated into the ONS 15454 MSPP system. The ML cards use a combination of the Cisco IOS command-line interface (CLI) and CTC for operational provisioning. ML-Series cards can support the RPR topology for bridging multiple LANs across a metro optical network. See Chapter 7 for a detailed explanation of RPR.

The ML-Series family consists of three different cards:

- **ML100T-12**—Provides 12 switched, autosensing, 10/100Base-T Ethernet ports for connecting to client equipment using RJ-45 faceplate connectors

- **ML100-FX**—Provides eight faceplate SFP receptacles supporting 10/100 SX and LX interfaces for connecting to client equipment
- **ML1000-2**—Provides two faceplate SFP receptacles supporting Gigabit SX and LX interfaces for connecting to client equipment

Each ML-Series card has two virtual Packet over SONET/SDH (POS) ports used to interconnect it to other Ethernet services interface cards (in the same or different ONS 15454 node), such as in a ring/RPR topology. These ports function similarly to OC-N card ports, and CTC is used to provision SONET/SDH circuits to these ports. The ML-Series cards can support contiguously concatenated (STS-1, STS-3c, STS-6c, STS-9c, STS-12c, STS-24c) and virtually concatenated (STS-1-2v, STS-3c-2v, STS-12c-2v) circuits. The ML-Series cards also support a software-based Link Capacity Adjustment Scheme (LCAS), which allows VCAT circuit group members to be added or removed from the circuit bandwidth in case of a failure or recovery from failure. Figure 6-12 shows an example of a four-node ONS 15454 MSPP ring equipped with seven total ML-Series cards being linked by SONET circuits over an OC-48 UPSR in an RPR configuration.

Figure 6-12 RPR Application over ONS 15454 MSPP Using ML-Series Cards Example

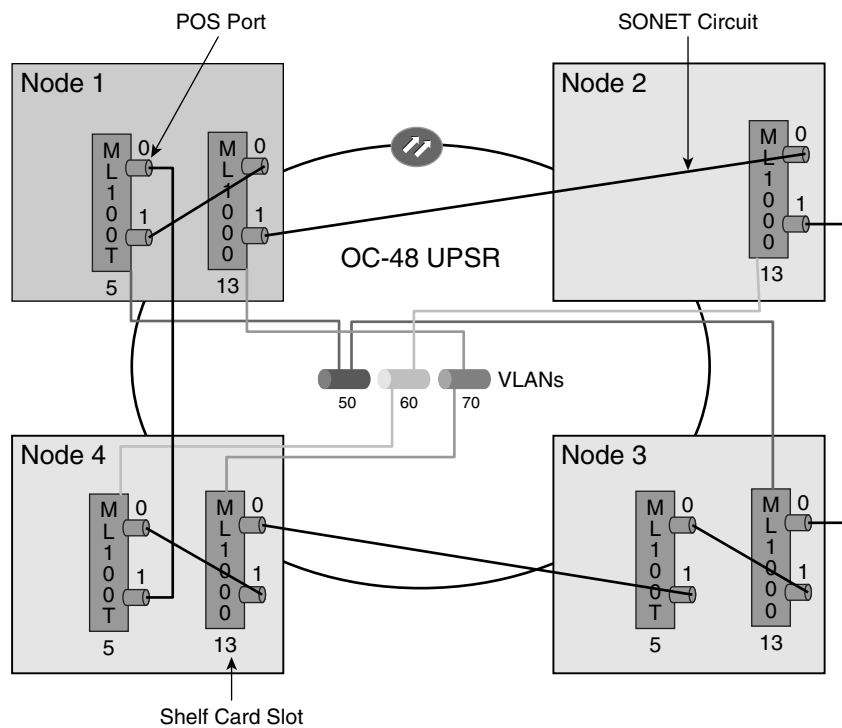

All ML-Series cards have an LED called ACT, which indicates the card's status, and an LED labeled FAIL, which remains illuminated if the card's processor is not ready or if a failure has occurred. Additionally, each card has a port LED, which is green to indicate a link and amber to indicate that the port is active.

Electrical Interface Cards

Electrical interface cards are used in the ONS 15454 to provide DS1, DS3, EC1, and DS3 transmux services. Table 6-7 provides a summary of the available electrical interface cards for the ONS 15454 MSPP, including the EIA types that can be used on a shelf side with each type of interface card.

Table 6-7 ONS 15454 Electrical Interface Card Summary

Card	Interface Type	Number of Ports	Bandwidth per Port	EIA Types Allowed
DS1-14/DS1N-14	DS1	14	1.544 Mbps	AMP Champ SMB UBIC-V UBIC-H
DS1-56	DS1	56	1.544 Mbps	UBIC-V UBIC-H
DS3-12/DS3N-12 DS3-12E/DS3N-12E	DS3	12	44.736 Mbps	BNC HD BNC HD Mini-BNC SMB UBIC-V UBIC-H
EC1-12	EC1	12	51.84 Mbps	BNC HD BNC HD Mini-BNC SMB UBIC-V UBIC-H
DS3/EC1-48	DS3/EC1	48	44.736 Mbps or 51.84 Mbps	HD Mini-BNC UBIC-V UBIC-H

Table 6-7 ONS 15454 Electrical Interface Card Summary (Continued)

Card	Interface Type	Number of Ports	Bandwidth per Port	EIA Types Allowed
DS3XM-6	DS3 transmux	6	44.736 Mbps	BNC HD BNC HD Mini-BNC SMB UBIC-V UBIC-H
DS3XM-12	DS3 transmux	12	44.736 Mbps	BNC HD BNC HD Mini-BNC SMB UBIC-V UBIC-H

All of the electrical interface cards are identical in appearance from their faceplate, with the exception of the card name marking. Each of the cards has three LEDs. The FAIL LED is an indication that the card is not yet ready, or that a card failure has occurred if it remains illuminated. The ACT/STBY LED is green for an active card and amber for a card in the standby state (protect card in a protection group). The SF lamp is illuminated to indicate a signal failure or a condition such as a loss of signal (LOS), a loss of frame (LOF), or a high bit error rate (BER) on one or more of the card's ports.

The sections that follow discuss each of the available electrical interface cards.

DS1-14 and DS1N-14 Interface Cards

DS1-14 and DS1N-14 cards each provide 14 DS1 ports, which operate at 1.544 Mbps. The difference between these two cards is that the DS1N-14 card contains additional circuitry, which allows it to act as the protection card in a 1: N (where N is less than or equal to 5) protection group (when installed in Slot 3 for Side A, or Slot 15 for Side B). The interface to these cards is through the shelf backplane EIA connectors. These cards can operate in any of the 12 traffic slots in the ONS 15454 chassis. A maximum of 12 DS1-14 or DS1N-14 cards can be active and providing service in a shelf. A typical shelf that is participating in a ring can have 112 working DS1 circuits using DS1-14 and DS1N-14 cards. This configuration would consist of ring OC-N cards in two slots, DS1N-14 standby cards in Slots 3 and 15, and working/active DS1-14 or DS1N-14 cards in the remaining eight slots, or 8 active cards \times 14 ports per card = 112 working service ports.

DS1-56 Interface Card

The DS1-56 interface card provides 56 DS1 ports operating at 1.544 Mbps. This card can function as a working card in shelf Slots 1, 2, 16, or 17, or as a protection card in Slot 3 (protecting working cards in Slots 1 and 2) and Slot 15 (protecting working cards in Slots 16 and 17). The interface to these cards is through the shelf backplane EIA connectors. A maximum of four DS1-56 cards can be active and providing service in a shelf. A typical shelf that is participating in a ring can have 224 working DS1 circuits using active DS1-56 cards in Slots 1, 2, 16, and 17, with optional protection/standby cards in Slot 3 (protecting Slots 1 and 2) and Slot 15 (protecting Slots 16 and 17), or 4 active cards \times 56 ports per card = 224 working service ports.

DS3-12, DS3N-12, DS3-12E, and DS3N-12E Interface Cards

DS3-12, DS3N-12, DS3-12E, and DS3N-12E cards each provide 12 DS3 ports, which operate at 44.736 Mbps. The distinction between the E versions (DS3-12E, DS3N-12E) and the non-E versions (DS3-12 and DS3N-12) is that the E versions have enhanced performance-monitoring capabilities that are not included in the non-E versions. This allows for earlier detection of transmission problems. In addition, each version has both regular (for example, DS3-12E) and N (for example, DS3N-12E) card types. The difference between these two cards is that the DS3N-12 and DS3N-12E cards contain additional circuitry, which allows them to act as the protection card in a 1:*N* (where *N* is less than or equal to 5) protection group (when installed in Slot 3 for Side A, or Slot 15 for Side B). The interface to these cards is through the shelf backplane EIA connectors. These cards can operate in any of the 12 traffic slots in the ONS 15454 chassis. A maximum of 12 DS3-12/DS3-12E and/or DS3N-12/DS3N-12E cards can be active and providing service in a shelf. A typical shelf that is participating in a ring can have 96 working DS3 circuits using DS3-12/DS3-12E and DS3N-12/DS3N-12E cards. This configuration would consist of ring OC-*N* cards in two slots, DS3N-12/DS3N-12E standby cards in Slots 3 and 15, and working/active DS3-12/DS3-12E or DS3N-12/DS3N-12E cards in the remaining 8 slots, or 8 active cards \times 12 ports per card = 96 working service ports.

EC1-12 Interface Cards

EC1-12 cards each provide 12 EC-1 ports, which operate at 51.84 Mbps. The interface to these cards is through the shelf backplane EIA connectors. These cards can operate in any of the 12 traffic slots in the ONS 15454 chassis. A maximum of 12 EC1-12 cards can be active and providing service in a shelf. EC1-12 cards support 1:1 card protection only (1:*N* protection is not an available option with the EC1-12 cards; there is no *N* version of the card). For 1:1 protection, the working/active EC1-12 cards are installed in even-numbered slots (2, 4, 6, 12, 14, and 16), while the protection/standby EC1-12 cards are installed in the corresponding odd-numbered slots. For example, an active EC1-12 card in Slot 2 can be

1:1 protected by a standby EC1-12 card in Slot 1. Another example is an active EC1-12 card installed in Slot 14, protected by a standby EC1-12 card installed in Slot 15. One possible shelf configuration using 1:1 protection groups with the EC1-12 cards would provide for 60 protected EC-1 ports. One example of this type of configuration would consist of ring OC-N cards installed in Slots 5 and 6; working/active EC1-12 cards installed in Slots 2, 4, 12, 14, and 16; and protection/standby EC1-12 cards installed in Slots 1, 3, 13, 15, and 17, or 5 active cards \times 12 ports per card = 60 working service ports.

DS3/EC1-48 Interface Cards

The DS3/EC1-48 interface card provides 48 DS3 (44.736 Mbps) or EC-1 (51.84 Mbps). With software releases 6 and higher, each port on the card can be user defined to operate as either a DS3 or an EC-1. This card can function as a working card in shelf Slots 1, 2, 16, or 17, or as a protection card in Slot 3 (protecting working cards in Slots 1 and 2) and Slot 15 (protecting working cards in Slots 16 and 17). The interface to these cards is through the shelf backplane EIA connectors. A maximum of four DS3/EC1-48 cards can be active and providing service in a shelf. A typical shelf that is participating in a ring can have 192 working DS3 and EC-1 circuits using active DS3/EC1-48 cards in Slots 1, 2, 16, and 17, with optional protection/standby cards in Slot 3 (protecting Slots 1 and 2) and Slot 15 (protecting Slots 16 and 17), or 4 active cards \times 48 ports per card = 192 working service ports.

DS3XM-6 and DS3XM-12 Interface Card

The DS3XM-6 interface card provides six M13 multiplexing ports, each of which converts a framed DS3 into 28 VT1.5s for grooming and cross-connection. This card can function as a working card in any slot, or as a protection card in a 1:1 protection group (in an even-numbered slot, with a working card in the adjacent odd slot). The DS3XM-6 card does not support the 1:N protection scheme. The interface to these cards is through the shelf backplane EIA connectors.

The DS3XM-12 interface card provides 12 M13 multiplexing ports, each of which converts a framed DS3 into 28 VT1.5s for grooming and cross-connection. This card can function as a working card in any slot, as a protection card in a 1:1 protection group (with a working card in an adjacent slot), or as a protection card in a 1:N protection group if located in Slot 3 or Slot 15. The DS3XM-12 interface cards can operate in one of two modes: ported or portless. In ported mode, the interface to each of the 12 card ports is through the shelf backplane EIA connectors. In portless mode, the M13 DS3 is groomed to an OC-N port on an optical card in the ONS 15454 for optical connection to an external switch. A variety of configurations can be supported using this interface card, with engineering rules based on the type of cross-connect card as well as the mode of operation. Consult the Cisco ONS 15454 Reference Manual for detailed usage information.

Storage Networking Cards

The SL-Series Fibre Channel(FC)/FICON (Fiber Connection) interface card for the ONS 15454 MSPP, also referred to as the FC_MR-4 card, is a four-port card used to provide storage-area networking (SAN) extension services over a SONET/SDH ring. This card can be installed in Slots 5, 6, 12, or 13 in a shelf equipped with XCVT cross-connect cards, or in any slot in a shelf equipped with XC10G or XC-VXC-10G cross-connect cards. Each of the four client ports can be independently equipped with 1-Gbps single-rate or 1-Gbps/2-Gbps dual-rate GBICs. Each port can support 1.0625 Gbps or 2.125 Gbps of FC/FICON connections. A maximum bandwidth of STS-48 is supported per card.

The SL-Series card supports both contiguously concatenated (CCAT) and virtually concatenated (VCAT) SONET/SDH circuits, as follows:

1 Gbps FC/FICON can be mapped into this:

- STS-1, STS-3c, STS-6c, STS-9c, STS-12c, STS-18c, STS-24c, and STS-48c (minimum SONET CCAT size for line-rate service is STS-24c)
- VC4-1c, VC4-2c, VC4-3c, VC4-4c, VC4-6c, VC4-8c, and VC4-16c (minimum SDH CCAT size for line-rate service is VC4-8c)
- STS-1-nv, where $n=1$ to 24 ($n = 19$ for line-rate service)
- STS-3c-nv, where $n=1$ to 8 ($n = 6$ for line-rate service)
- VC4-nv, where $n=1$ to 8 ($n = 6$ for line-rate service)

2-Gbps FC/FICON can be mapped into:

- STS-1, STS-3c, STS-6c, STS-9c, STS-12c, STS-18c, STS-24c, and STS-48c (minimum SONET CCAT size for line-rate service is STS-48c)
- VC4-1c, VC4-2c, VC4-3c, VC4-4c, VC4-6c, VC4-8c, VC4-12c, and VC4-16c (minimum SDH CCAT size for line-rate service is VC4-16c)
- STS-1-nv, where $n = 1$ to 48 ($n = 37$ for line-rate service)
- STS-3c-nv, where $n = 1$ to 16 ($n = 12$ for line-rate service)
- VC4-nv, where $n = 1$ to 16 ($n = 12$ for line-rate service)

The SL-Series cards also support advanced SAN distance extension features, including the use of buffer-to-buffer (B2B) credits, which are supported by the connected FC switching devices, to overcome distance limitations in 1-Gbps and 2-Gbps line-rate SAN extension applications. Additionally, distance extensions functions enabled by Receiver Ready (R_RDY) spoofing enables the SL Series to serve as an integrated FC extension device, reducing the need for external equipment.

MSPP Network Design Case Study

A major healthcare services provider in a large metropolitan area is currently preparing to implement a major upgrade to its data and telecommunications networks. Backbone connectivity for University Healthcare System, Inc. (UHCS), in Brounville is currently provided using multiple T1, DS3, and OC-3 links provided by a local exchange carrier, BrounTel. These leased lines are used for connectivity among various company locations, such as the corporate headquarters campus and various hospital locations throughout the metro area. These services are provisioned through a combination of BrounTel copper T1 span lines, legacy point-to-point asynchronous optical multiplexers, and first-generation SONET OC-3 and OC-12 systems. The company is seeking to upgrade its current network services for several reasons:

- **Network survivability**—To ensure business continuity, the UHCS IT staff wants to improve the reliability of its leased network services. In the past, the nonredundant portions of the network serving some of its locations have failed, causing unacceptable service outage times.
- **Flexibility**—A major driver in the upgrade decision is the capability to add bandwidth and services with the simple addition or upgrade of existing components, versus the delay associated with conditioning new T1 span lines or adding fiber facilities.
- **Scalability**—UHCS seeks to future-proof its infrastructure so that the network can grow as the business continues to expand.
- **Advanced network services**—Line-rate and sub-rate GigE connections are among the current network requirements, and storage networking, 10 GigE, and wavelength services could become requirements in the long term. These services cannot be provided using the existing BrounTel network facilities that serve the UHCS locations.
- **Cost reduction**—By reducing their network to a simpler, more advanced technology platform, the company plans to reduce recurring costs paid to BrounTel.

After discussing service requirements and contract terms with BrounTel, the IT managers have elected to contract with BrounTel to provide a leased dedicated SONET ring (DSR) service for connectivity between company sites, and for access to the public switched telephone network (PSTN). BrounTel will deploy a Cisco ONS 15454 MSPP solution for the DSR.

MSPP Ring Network Design

A total of seven sites in various parts of the metro area will need connectivity to the new network. BrounTel has existing standard single-mode fiber (SMF) optic cables serving some of the locations; it will use existing cable or build new optical cable facilities as required for diverse routing between the company locations and multiple BrounTel central

offices. Three central office locations will have MSPP nodes on the SONET ring; the others will serve as fiber patch (or pass-through) locations. Table 6-8 gives a list of location names, addresses, and site types.

Table 6-8 *University Healthcare System DSR Locations and Requirements*

Node Number	Site Name	Site Address	Site Type
0	University Hospital North (UHCS)	4303 Thach Avenue	MSPP Node
-	Foy Central Office (BrounTel)	307 Duncan Drive	Fiber Patch
1	Magnolia Central Office (BrounTel)	41 Magnolia Avenue	MSPP Node
2	University Healthcare HQ (UHCS)	130 Donahue Drive	MSPP Node
-	Poplar Street Central Office (BrounTel)	8016 Poplar Street	Fiber Patch
3	Brounville Main Central Office (BrounTel)	2004 Elm Street	MSPP Node
4	University Medical Center (UHCS)	34 South College Street	MSPP Node
-	Beech Street Central Office (BrounTel)	2311 Beech Street	Fiber Patch
5	University Hospital East (UHCS)	1442 Wire Road	MSPP Node
-	Roosevelt Drive Central Office (BrounTel)	1717 Roosevelt Drive	Fiber Patch
6	Samford Avenue Central Office (BrounTel and IXC POP)	940 Samford Avenue	MSPP Node
-	Mell Street Central Office (BrounTel)	1183 Mell Street	Fiber Patch
7	University Hospital South (UHCS)	9440 Parker Circle	MSPP Node
-	Haley Central Office (BrounTel)	1957 Concourse Way	Fiber Patch
-	Ross Central Office (BrounTel)	60 Wilmore Road	Fiber Patch
8	UHCS Data Center (UHCS)	1983 Draughon Trace	MSPP Node
-	Ramsay Central Office (BrounTel)	2322 Hemlock Drive	Fiber Patch
9	Jordan Memorial Hospital (UHCS)	1969 Goodwin Lane	MSPP Node
-	Morrison Central Office (BrounTel)	141 Morrison Drive	Fiber Patch

Table 6-9 shows the measured (for existing facilities) or calculated (for proposed facilities) fiber cable loss figures for the ring facilities. All loss figures include losses because of splices, connectors and patch panels, as well as the cable loss.

Table 6-9 *Fiber Cable Losses for UHCS Ring Network*

Fiber Span Number	From Location	To Location	Distance (km)	Loss at 1310 nm (dB)	Loss at 1550 nm (dB)
1	University Hospital North (UHCS)	Foy Central Office (BrounTel)	12.3	7.42	5.38
2	Foy Central Office (BrounTel)	Magnolia Central Office (BrounTel)	13.8	8.12	5.79
3	Magnolia Central Office (BrounTel)	University Healthcare HQ (UHCS)	17.1	9.53	6.73
4	University Healthcare HQ (UHCS)	Poplar Street Central Office (BrounTel)	6.2	3.73	2.76
5	Poplar Street Central Office (BrounTel)	Brounville Main Central Office (BrounTel)	7.1	4.15	3.08
6	Brounville Main Central Office (BrounTel)	University Medical Center (UHCS)	18.9	11.16	6.98
7	University Medical Center (UHCS)	Beech Street Central Office (BrounTel)	9.4	5.92	3.70
8	Beech Street Central Office (BrounTel)	University Hospital East (UHCS)	8.7	5.48	3.43
9	University Hospital East (UHCS)	Roosevelt Drive Central Office (BrounTel)	13.2	8.58	5.37
10	Roosevelt Drive Central Office (BrounTel)	Samford Avenue Central Office (BrounTel and IXC POP)	7.0	4.73	3.25
11	Samford Avenue Central Office (BrounTel and IXC POP)	Mell Street Central Office (BrounTel)	12.3	7.06	4.97

continues

Table 6-9 *Fiber Cable Losses for UHCS Ring Network (Continued)*

Fiber Span Number	From Location	To Location	Distance (km)	Loss at 1310 nm (dB)	Loss at 1550 nm (dB)
12	Mell Street Central Office (BrounTel)	University Hospital South (UHCS)	21.0	11.38	7.11
13	University Hospital South (UHCS)	Haley Central Office (BrounTel)	8.3	4.32	2.70
14	Haley Central Office (BrounTel)	Ross Central Office (BrounTel)	12.4	8.10	5.65
15	Ross Central Office (BrounTel)	UHCS Data Center (UHCS)	13.8	8.99	6.07
16	UHCS Data Center (UHCS)	Ramsay Central Office (BrounTel)	6.7	4.25	2.66
17	Ramsay Central Office (BrounTel)	Jordan Memorial Hospital (UHCS)	8.3	4.17	3.13
18	Jordan Memorial Hospital (UHCS)	Morrison Central Office (BrounTel)	10.3	7.72	5.33
19	Morrison Central Office (BrounTel)	University Hospital North (UHCS)	8.4	4.6	3.55

Because of the relatively short distances between MSPP node locations, polarization mode dispersion (PMD) will not be an issue in this deployment.

To determine the bandwidth requirements for the ring, the UHCS service demands must be considered. These services will be provided using the DSR:

- **Multipoint Switched Ethernet** will be used to connect the LANs at all the UHCS sites together using a resilient packet ring (RPR) with GigE links.
- **Private line Ethernet** connections, which are point-to-point Ethernet transport “pipes,” will be used between a subset of the UHCS sites.
- **TDM services**, including DS1 and DS3 links, will be required for transport of voice traffic between UHCS Private Branch eXchange (PBX) systems, and between UHCS sites and BrounTel central offices.

Listing the requirements individually, take a look at Table 6-10, which shows the planned circuits for the ring.

Table 6-10 *DSR Circuit Requirements*

Circuit Type	Circuit Size	Quantity	Protection?	Locations	Purpose
GigE	STS-24c	1	None	Node 0 to Node 2	RPR for production data
GigE	STS-24c	1	None	Node 2 to Node 4	RPR for production data
GigE	STS-24c	1	None	Node 4 to Node 5	RPR for production data
GigE	STS-24c	1	None	Node 5 to Node 7	RPR for production data
GigE	STS-24c	1	None	Node 7 to Node 8	RPR for production data
GigE	STS-24c	1	None	Node 8 to Node 9	RPR for production data
GigE	STS-24c	1	None	Node 9 to Node 0	RPR for production data
GigE	STS-24c	1	UPSR	Node 0 to Node 2	Private line video and data application
GigE (Sub-Rate)	STS-12c	1	UPSR	Node 0 to Node 5	Private line video and data application
GigE (Sub-Rate)	STS-12c	1	UPSR	Node 0 to Node 7	Private line video and data application
DS3	STS-1	2	UPSR	Node 1 to Node 8	Data access
DS3	STS-1	3	UPSR	Node 2 to Node 6	Data access
DS3	STS-1	1	UPSR	Node 2 to Node 3	Data access
DS1	VT1.5	3	UPSR	Node 0 to Node 9	PBX voice trunks
DS1	VT1.5	4	UPSR	Node 0 to Node 2	PBX voice trunks
DS1	VT1.5	5	UPSR	Node 1 to Node 8	Voice access

continues

Table 6-10 *DSR Circuit Requirements (Continued)*

Circuit Type	Circuit Size	Quantity	Protection?	Locations	Purpose
DS1	VT1.5	2	UPSR	Node 2 to Node 9	PBX voice trunks
DS1	VT1.5	4	UPSR	Node 2 to Node 8	PBX voice trunks
DS1	VT1.5	3	UPSR	Node 2 to Node 7	PBX voice trunks
DS1	VT1.5	22	UPSR	Node 2 to Node 6	Voice access
DS1	VT1.5	3	UPSR	Node 2 to Node 5	PBX voice trunks
DS1	VT1.5	4	UPSR	Node 2 to Node 4	PBX voice trunks
DS1	VT1.5	2	UPSR	Node 2 to Node 3	Voice access
DS1	VT1.5	3	UPSR	Node 4 to Node 8	PBX voice trunks
DS1	VT1.5	2	UPSR	Node 5 to Node 7	PBX voice trunks
DS1	VT1.5	2	UPSR	Node 7 to Node 9	PBX voice trunks
DS1	VT1.5	2	UPSR	Node 7 to Node 8	PBX Voice Trunks

To calculate the bandwidth requirements for the ring, simply add each of the individual requirements to arrive at the total number of STS-1s needed. This calculation is shown in Table 6-11.

Table 6-11 *Ring Bandwidth Requirements*

Circuit(s)	Number of Ring STS-1s Required
(7) Unprotected GigE RPR links	24
(1) UPSR-Protected Line-Rate GigE	24
(2) UPSR-Protected Sub-Rate GigE (12 STS-1)	24
(6) UPSR-Protected DS3s	6
(61) UPSR-Protected DS1s	3
Total STS-1s Required	81

NOTE The GigE links that form the RPR reuse the same bandwidth throughout the ring because they are built without SONET protection.

Because the initial requirements are 81 STS-1s, an OC-192 ring will be used. This allows sufficient capacity for the existing service requirements, as well as for future growth to the network.

OC-192 Ring Transmission Design

Having defined the network bandwidth requirements to be OC-192, you can now select the appropriate OC-192 interfaces to equip at each ONS 15454 MSPP node to link the ring sites. ONS 15454 OC-192 IR interfaces transmit at a nominal wavelength of 1550 nm and have an allowable link loss budget of about 13 dB. OC-192 LR interfaces also transmit at the 1550 nm wavelength and have an allowable link loss budget of 26 dB. There is also an available SR OC-192 interface, but the small allowable link loss budget is not suitable for the distances involved in the UHCS application. Therefore, either the IR or LR optics will be used, with 10 dB being the “breakpoint” between the two. This allows 3 dB of margin for future loss increases due to fiber cable degradation, future repair splicing, and component aging.

Based on the specifications of the various ONS 15454 OC-192 interfaces and the loss characteristics of each fiber section (outlined in Table 6-9), the node-to-node interface types can be determined for the ring. OC-192/10G operation is allowed in chassis Slots 5, 6, 12, and 13. You use a pair of these slots at each location for the East- and West-facing ring interfaces. Although any combination of two of the four available slots is acceptable, uniformly select Slots 5 and 6 at each of the nodes for operational simplicity. Table 6-12 shows the selection of OC-192 optics for each ring span.

Table 6-12 OC-192 Ring Optics for UHCS DSR

From East Node/Slot	To West Node/Slot	Loss at 1550 nm (dB)	OC-192 Interface Type
Node 0 Slot 6	Node 1 Slot 5	11.17	OC-192 1550 LR
Node 1 Slot 6	Node 2 Slot 5	6.73	OC-192 1550 IR
Node 2 Slot 6	Node 3 Slot 5	5.84	OC-192 1550 IR
Node 3 Slot 6	Node 4 Slot 5	6.98	OC-192 1550 IR
Node 4 Slot 6	Node 5 Slot 5	7.13	OC-192 1550 IR
Node 5 Slot 6	Node 6 Slot 5	8.62	OC-192 1550 IR
Node 6 Slot 6	Node 7 Slot 5	12.08	OC-192 1550 LR
Node 7 Slot 6	Node 8 Slot 5	14.42	OC-192 1550 LR
Node 8 Slot 6	Node 9 Slot 5	5.79	OC-192 1550 IR
Node 9 Slot 6	Node 0 Slot 5	8.88	OC-192 1550 IR

In addition to the optical trunk interface card selection, one of the BrounTel central office nodes will be designated as the Gateway Network Element (GNE) and will connect to BrounTel's Network Operations Center (NOC) using its IP-based interoffice management network. The Magnolia central office MSPP node will be chosen as the GNE.

For the purposes of network synchronization, each MSPP node located in a BrounTel central office will be connected to the office BITS and will be configured as externally timed. Line timing will be configured on the ONS 15454 systems located in the UHCS customer premises sites, with the OC-192 optical interface ports on the cards installed in Slots 5 and 6 serving as the primary and secondary reference sources.

With all the necessary parameters now defined, you can prepare all necessary engineering documentation, such as the network map, shelf card slot assignments, chassis EIA equipage, tributary protection group configuration, and cabling termination assignments.

Network Map

The network map or ring map is a key piece of documentation that assists in bringing an MSPP network online, as well as a future as-built reference for planning, troubleshooting, and performing upgrades or additions. Figure 6-13 shows the network map for the UHCS DSR. The following information has been included:

- Graphical representation of the network topology
- Location of all MSPP nodes and fiber pass-through offices (no equipment—just interconnection of outside plant fiber cables)
- Distance and loss/attenuation figures for each fiber link
- Slot assignments and card types for the interconnecting OC-192 interface cards
- Node names, IP addresses, and timing configurations
- GNE assignment and IP address of the default router
- Software version

The node numbers and Ring ID have also been provided as reference information; however, because this is not a BLSR network, this information is not required to provision the ring nodes.

Shelf Card Slot Assignments, EIA Equipage, and Tributary Protection Group Configuration

The versatility of the ONS 15454 MSPP gives the BrounTel engineers multiple options when selecting the chassis card slot assignments. Some assignments will be common for all ring nodes; others might vary to allow for maximum flexibility to add future services to the network.

Figure 6-13 UCHS DSR Ring Map

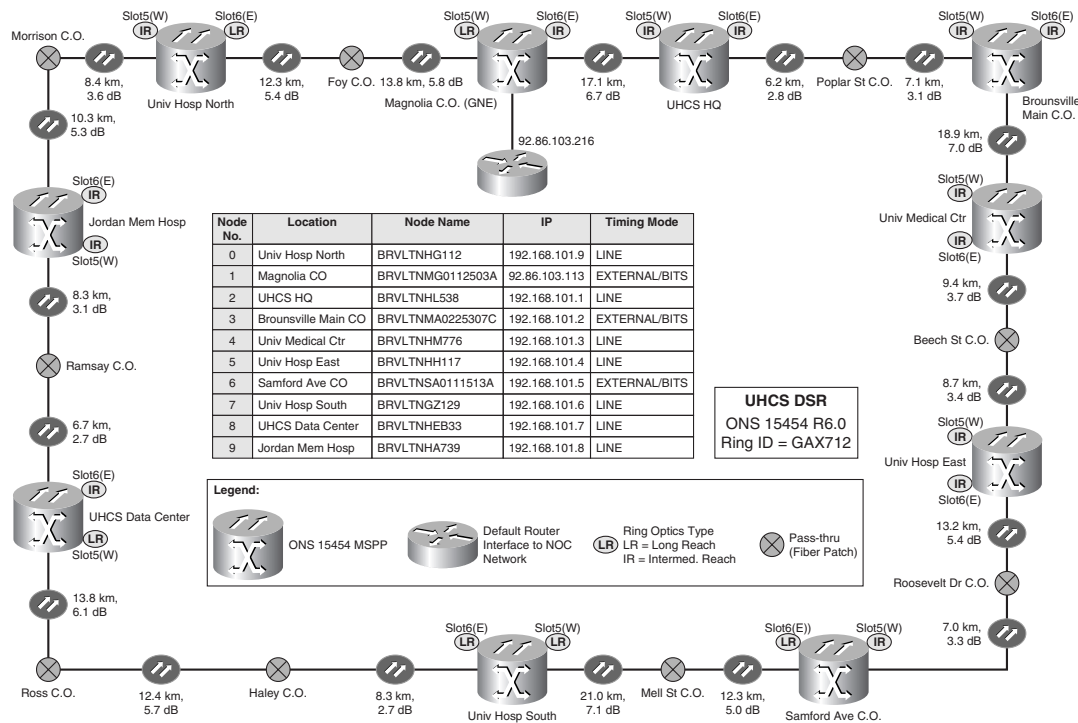

An important factor in the determination of card slot assignments for electrical interface cards, such as the DS1 and DS3 cards in the UHCS ring, is the type of tributary card protection required. Additionally, these interface types and their locations will help to determine the type of EIA that must be ordered for the ONS 15454 chassis.

All 10 of the ring nodes have the TCCP2 cards in Slots 7 and 11. Recall that two TCC cards are required in every ONS 15454 MSPP node. Likewise, two XC-VXC-10G cross-connect cards will be placed in Slots 8 and 10 for each node. Finally, for standardization and operational simplicity, the OC-192 ring interface cards will be placed in Slots 5 (West) and 6 (East) in each of the ring nodes. For the other interface cards required in the ring nodes, customized slot assignments will be specified. According to the conditions of the DSR service contract, BrounTel will design all TDM service interfaces to be card-protected in either 1:1 or 1:N protection groups. Of course, the Ethernet service interfaces will be unprotected.

At the University Hospital–North node (Node 0), the initial service-termination requirements include seven DS1 circuits, three private-line GigE links (one line rate and two subrate), and the GigE RPR circuit connections. Figure 6-14 shows the shelf diagram with card locations for this node. The DS1s require a single working DS1-14 card. This card

UCHS Headquarters (Node 2)

Initial requirements are 44 DS1s, 4 DS3s, 1 line-rate private line Ethernet circuit, and the RPR GigE links. The high-density (56-port) DS1 card will be used on Side B, with the DS3 cards on Side A. Both shelf sides will be equipped with the UBIC-H EIA. See Figure 6-16 for the shelf diagram.

Figure 6-16 UCHS Headquarters Node—Shelf Diagram

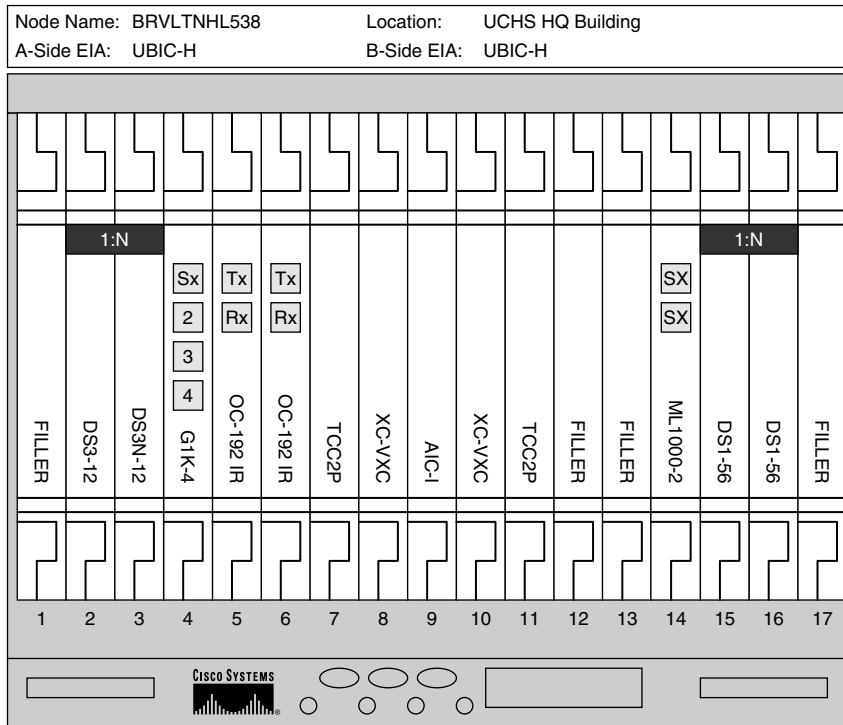

Brounville Main Central Office (Node 3)

Requirements are for two DS1s and one DS3. Both interface types will be slotted on Side B, and a UBIC-H EIA will be equipped on the rear to accommodate the cabling for these cards. See Figure 6-17 for the shelf diagram.

University Medical Center (Node 4)

Initial requirements are for seven DS1s, as well as the RPR GigE links. DS1 interface cards and a UBIC-H EIA will be installed on Side B, with the ML1000-2 card and associated SX SFPs on Side A. See Figure 6-18 for the shelf diagram.

Figure 6-17 Brounsville Main Central Office Node—Shelf Diagram

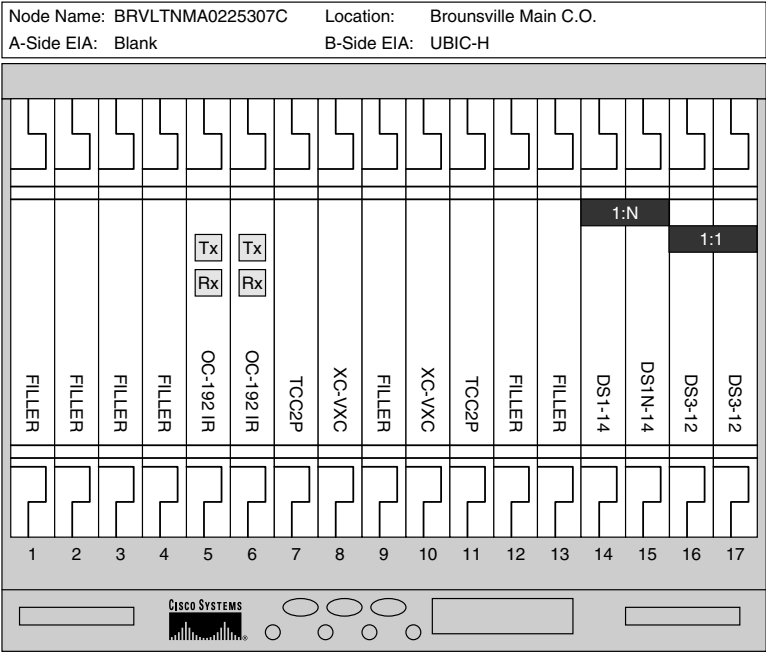
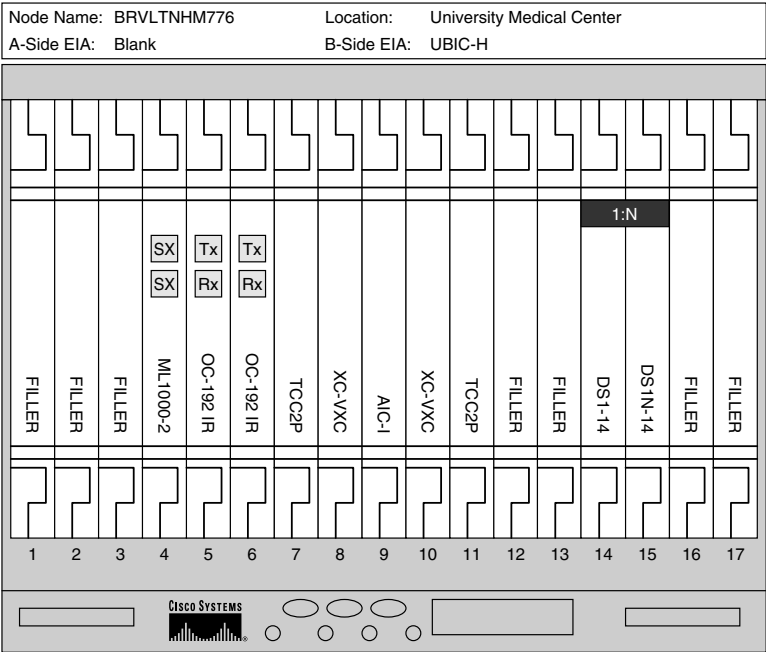

Figure 6-18 University Medical Center Node—Shelf Diagram



University Hospital—East (Node 5)

Five DS1s, a single subrate GigE private line circuit, and the RPR GigE links must be provisioned at this location. A DS1-14 card will be placed in Slot 14 and will be protected by a DS1N-14 card in Slot 15. The Ethernet cards will be installed on the A Side. Because electrical interfaces are required to be cabled only from the B side of the shelf, no EIA will be required to be installed on Side A. See Figure 6-19 for the shelf diagram.

Figure 6-19 University Hospital—East Node—Shelf Diagram

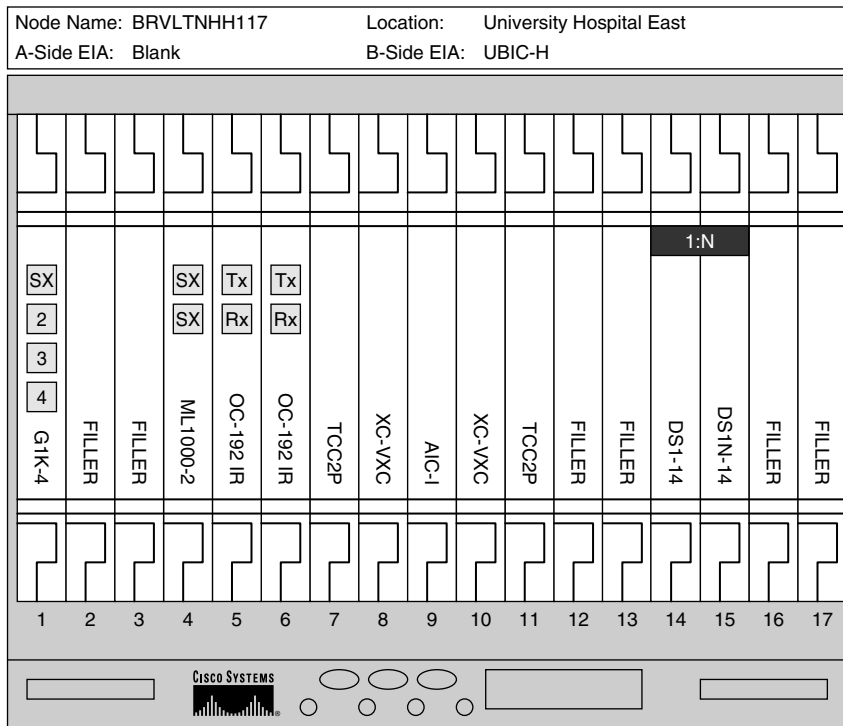

Samford Avenue Central Office (Node 6)

Initial requirements are for 22 DS1s and 3 DS3s. A pair of DS1-14 cards will be placed in Slots 16 and 17, with both cards being protected in a 1:N group by a DS1N-14 card in Slot 15. The DS3-12E card will be placed in Slot 2 and will be protected by a DS3N-12E card in Slot 3. UBIC-H EIAs will be installed on the rear for both sides. See Figure 6-20 for the shelf diagram.

University Hospital—South (Node 7)

Nine DS1s, a subrate (STS-12c) GigE private line connection, and the RPR GigE links are required. See Figure 6-21 for the shelf diagram.

Figure 6-20 *Samford Avenue Central Office Node—Shelf Diagram*

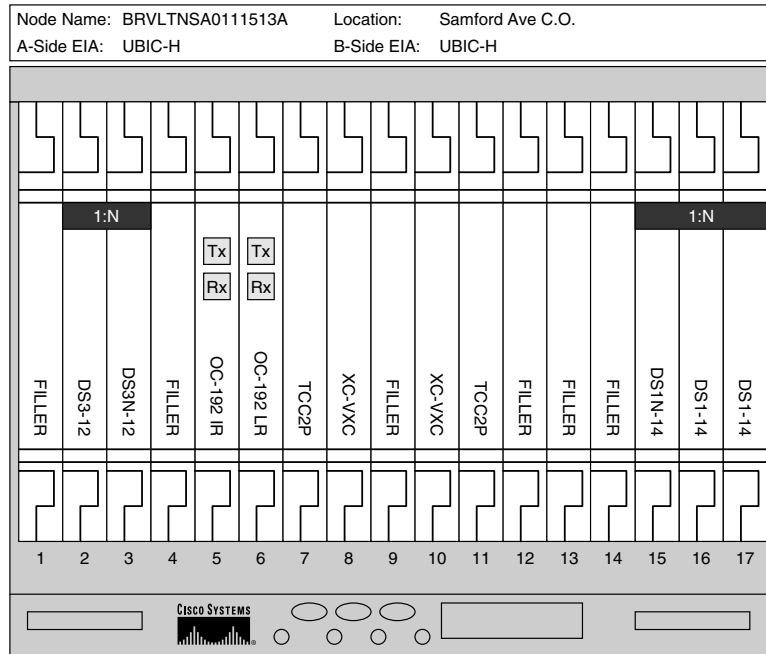
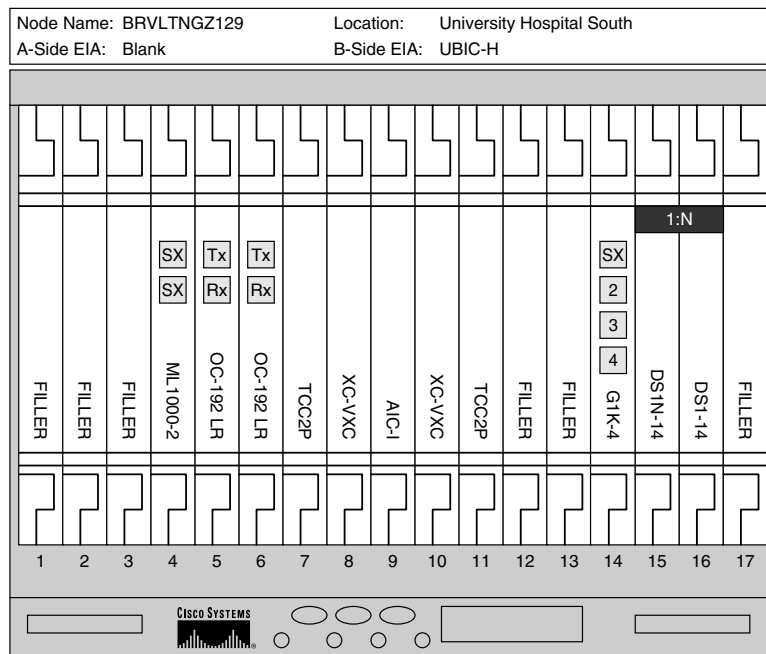

Figure 6-21 *University Hospital—South Node—Shelf Diagram*



UCHS Data Center (Node 8)

Initial requirements include 14 DS1s, 2 DS3s, and the RPR GigE links. Electrical interfaces will be installed only on Side B. See Figure 6-22 for the shelf diagram.

Figure 6-22 UCHS Data Center Node—Shelf Diagram

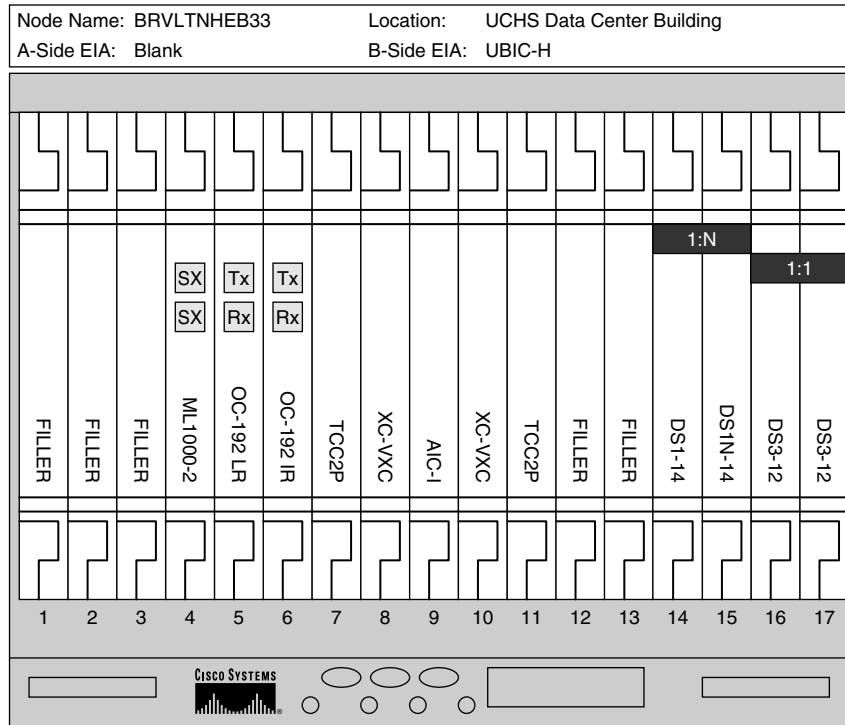

Jordan Memorial Hospital (Node 9)

Seven DS1s and the RPR GigE links are the initial requirements here. See Figure 6-23 for the shelf diagram.

Cabling Terminations

The UHCS DSR requires various interface types to be cabled out for interconnecting to the customer premises equipment (CPE) at UHCS locations, or for interfacing with the BrounTel or Interexchange Carrier (IXC) networks at the central office locations. Figure 6-24 shows a

diagram with typical interface cabling for an ONS 15454 node location on the UHCS ring: the UHCS Headquarters node. The OC-192 ring optics will be cabled to the outside plant (OSP) fiber-termination panel using single-mode optical fibers from the SC faceplate connectors. DS1 and DS3 interface cards will be cabled to digital signal cross-connect (DSX) panels via the backplane UBIC EIA connectors. Ethernet interface cards, including the G1K-4 and ML1000-2, will be cabled to an optical splitter module panel using multimode fibers from the GBIC SC faceplate connectors (G1K-4) or the SFP LC faceplate connectors (ML1000-2).

Figure 6-23 Jordan Memorial Hospital Node—Shelf Diagram

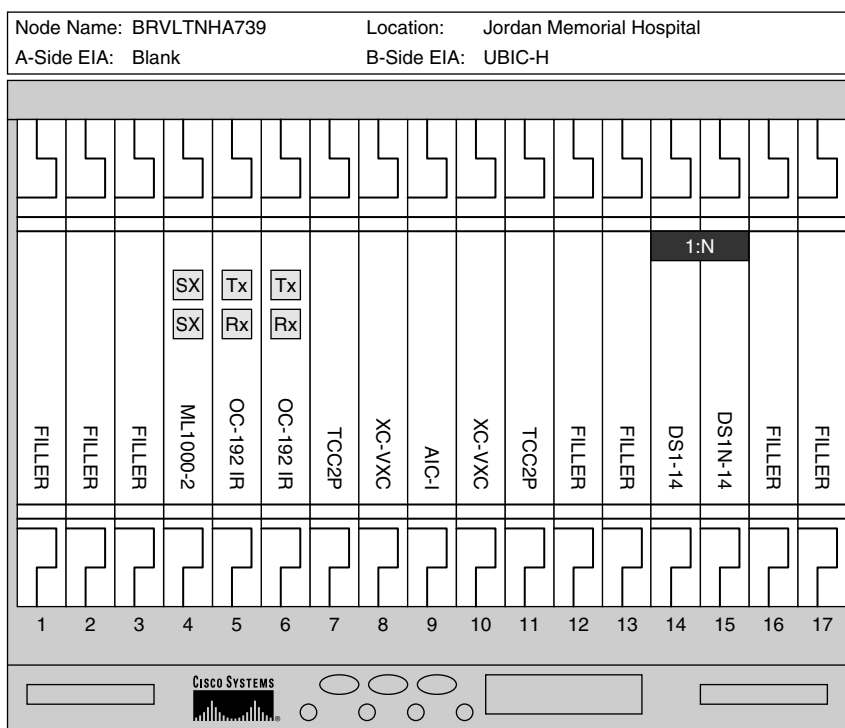

Table 6-13 shows an example cabling termination assignment chart for the UHCS Headquarters location.

Figure 6-24 Cabling Termination Diagram, UCHS Headquarters Node

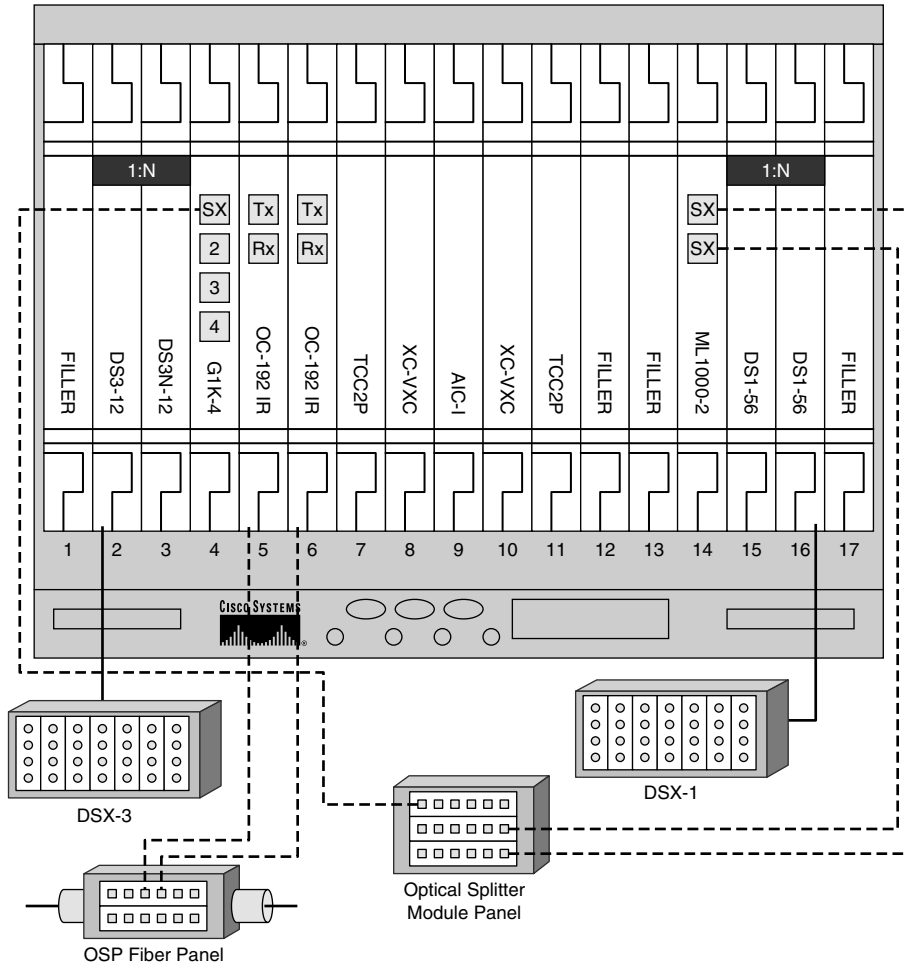

Table 6-13 Customer Drop Cabling Terminations for UHCS HQ Node

Panel Type	Panel Location	Connector/Jack	To Equipment	To Slot/Port
Optical	RR 101 PNL 4	1	ONS RR 101A	Slot 5 Tx
		2	ONS RR 101A	Slot 5 Rx
		3	ONS RR 101A	Slot 6 Tx
		4	ONS RR 101A	Slot 6 Rx
		5-24	FUTURE	FUTURE

Table 6-13 *Customer Drop Cabling Terminations for UHCS HQ Node (Continued)*

Panel Type	Panel Location	Connector/Jack	To Equipment	To Slot/Port
Optical/ Splitter	RR 101 PNL 3	Mod 1 SRC Tx	ONS RR 101A	Slot 4/1 Tx
		Mod 1 SRC Rx	ONS RR 101A	Slot 4/1 Rx
		Mod 1 Cus Tx	ONS RR 101A	CPE Tx
		Mod 1 Cus Rx	ONS RR 101A	CPE Rx
		Mod 2 SRC Tx	ONS RR 101A	Slot 14/1 Tx
		Mod 2 SRC Rx	ONS RR 101A	Slot 14/1 Rx
		Mod 2 Cus Tx	ONS RR 101A	CPE Tx
		Mod 2 Cus Rx	ONS RR 101A	CPE Rx
		Mod 3 SRC Tx	ONS RR 101A	Slot 14/2 Tx
		Mod 3 SRC Rx	ONS RR 101A	Slot 14/2 Rx
		Mod 3 Cus Tx	ONS RR 101A	CPE Tx
		Mod 3 Cus Rx	ONS RR 101A	CPE Rx
DSX-1	RR 101 PNL 2	1-56	ONS RR 101A	Slot 16/1-56
		57-84	FUTURE	FUTURE
DSX-3	RR 101 PNL 1	1-12	ONS RR101A	Slot 2/1-12

Summary

This chapter looked at the Cisco ONS 15454 MSPP, which is one of the most widely deployed MSPP systems worldwide. The system components, both hardware (shelf assembly, backplane interfaces, and EIAs) and interface modules (common/control, optical cards, Ethernet services cards, and electrical interface cards) were briefly described to provide an understanding of the basic functionality of the ONS 15454 MSPP.

After exploring the system, a network design example was presented. After identifying the requirements for the end customer, the entire network was designed, including network map, ring optics transmission design, interface slotting, EIA selection, protection group assignment, and interface cabling plan.